

new

Rotational Speed Sensor FUA 919-3

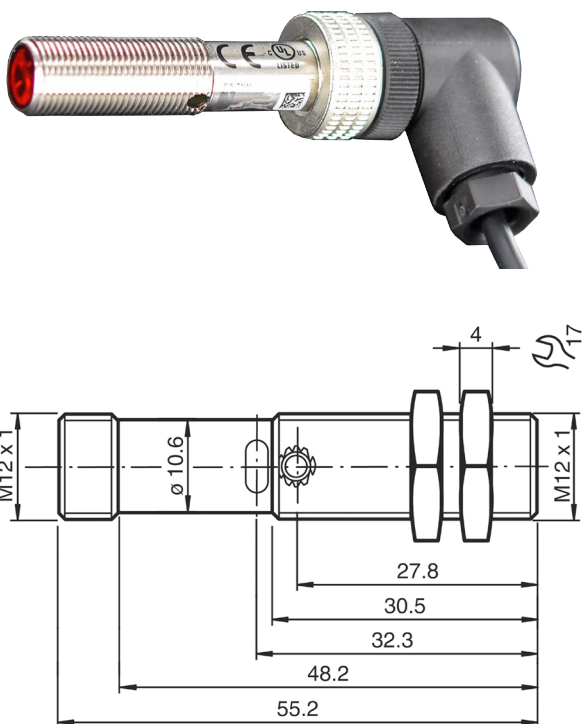

- Optical probe for measurements of rotational speed, designed as retroreflective photoelectric sensor for photoelectric detection of rotational speeds.
- For evaluation of the pulses, the tachometer probe is equipped with a specific frequency meter module that calculates the number of revolutions per minute from the time period between two pulses. A stable read-out is achieved by averaging over a minimum of 500 ms.
- Easy application: A reflective adhesive tape is attached to the moving part and the probe is aligned with it. For function control purposes a yellow signal lamp at the rear side of the probe will be on when the reflective adhesive tape is recognised.
- To increase the operation reliability the sensitivity can be adjusted through a potentiometer.

Technical Data:

Measuring range:	8 bis 30000 UpM	Switching frequency:	< 1000 Hz
Resolution:	1 UpM	Ambient temperature:	-30°C to +60°C
Accuracy:		Storage temperature:	-40°C to +70°C
up to 15000 rpm:	± 0.02 % of m.v. ± 1 digit	Protection system:	IP 67
up to 30000 rpm:	± 0.05 % of m.v. ± 1 digit	No-load current:	≤ 15 mA
Detection range:	20 bis 300 mm (depending on the reflector)	Supply voltage:	via ALMEMO® connector
Reference object:	standard white 100 mm x 100 mm	Connection:	Device connector M12x1 including socket M12x1, angled, with 1.5 meters cable and ALMEMO® connector
Sensitivity:	adjustable with potentiometers	Material:	
Detectable object:	opaque or reflector	Housing:	brass, nickel plated,
Type of light:	red light 640 nm	Lens opening:	PMMA
Light spot diameter:	appr. 20 mm at intervals of 300 mm	Dimensions:	
A perture angle:	appr. 4°	Diameter:	M12 x 1mm,
Limit for foreign light:	EN 60947-5-2: 10000 lux	length:	55mm
Display switching status:	LED yellow		

Accessories

	Order no.
Extension cable, 1 meter long	ZA9060VK1
Extension cable, 2 meters long	ZA9060VK2

Types

	Order no.
Rotational Speed Sensor up to 30000rpm max., incl. 5 reflective adhesive tapes	
Connecting cable 1.5m long with ALMEMO® connector	FUA9193