



Indigo200 Series Transmitters

For Vaisala Indigo-compatible probes



Features

- Transmitter USB-C port allows connecting to Vaisala Insight PC software with a generic USB cable
- Numerical and graphical color display (optional non-display version for analog model)
- IP65 enclosure
- 24 V AC/DC power supply input
- Indigo201: 3 analog outputs (mA or V)
- Indigo202: RS-485 with Modbus® RTU
- 2 configurable relays

Vaisala Indigo200 series transmitters are host devices for displaying measurement values from Vaisala Indigo-compatible probes and transmitting measurements to automation systems through analog signals, Modbus RTU communication, or relays.

Transmitter for Vaisala Indigo-compatible probes

- HMP series humidity and temperature probes HMP1, HMP3, HMP4, HMP5, HMP7, HMP8, HMP9
- TMP1 temperature probe
- DMP series dew point probes DMP5, DMP6, DMP7, DMP8
- GMP250 series CO₂ probes GMP251, GMP252
- HPP270 series vaporized hydrogen peroxide probes HPP271, HPP272
- MMP8 moisture in oil probe

Indigo200 series transmitters are plug-and-play probe host devices for current and future Vaisala Indigo-compatible probes. The host device has a color display with numeric and graph measurement viewing options; Indigo201 is also available as a non-display version that uses an LED indicator for notifications.

Vaisala Indigo-compatible probes are connected either directly to the host or by using a cable between Indigo200 and the probe.

The surface of the Indigo200 enclosure is smooth, which makes it easy to clean. It is also resistant to dust and most chemicals, such as H₂O₂ and alcohol-based cleaning agents.

For easy access to configuration and monitoring options, Indigo200 can be connected to Vaisala Insight PC software using the USB-C port on the transmitter with any generic USB cable that has a USB-C connector.

With Insight PC software, you can configure both the host device and the probes connected to it. Insight PC software also provides options for temporary viewing of the measurement data and diagnostics.

For more information on Indigo transmitters and the Indigo product family, see www.vaisala.com/indigo.



幸託有限公司
XIN TOP CORPORATION

TEL : (02)2598-1199
FAX : (02)2596-2331

E-mail : info@xintop.com
Website : www.xintop.com

Technical data

General

- Color display (Indigo201: optional non-display version)
- USB connection to Vaisala Insight PC software for easy access to configuration and monitoring options.

Indigo-compatible probes

Measurement type	Probe models
Humidity and temperature	HMP1, HMP3, HMP4, HMP5, HMP7, HMP8, HMP9
Temperature	TMP1
Dew point	DMP5, DMP6, DMP7, DMP8
Carbon dioxide	GMP251, GMP252
Vaporized hydrogen peroxide	HPP271, HPP272
Moisture in oil	MMP8

Operating environment

Operating temperature	With display
	-20 ... +60 °C (-4 ... +140 °F)
	Without display
	-40 ... +60 °C (-40 ... +140 °F)
Storage temperature	-40 ... +70 °C (-40 ... +158 °F)
Chemical tolerance	Temporary exposure during cleaning: <ul style="list-style-type: none"> • H₂O₂ (6000 ppm, non-condensing) • Alcohol-based cleaning agents such as ethanol and IPA (max. 70 % concentrate)
IP rating	IP65
Indoor/outdoor use	Indoor use

Inputs and outputs

Insight PC software configuration access ¹⁾	USB-C port on transmitter (compatible with generic USB cables)
Power supply input	15 ... 30 V DC ²⁾ 24 V AC ±10 % 50/60 Hz
Relay contacts x 2	Max. switching current 1 A Max. switching voltage 40 V DC / 28 V AC

Indigo201 model

Three analog outputs (voltage or current)	Voltage: 0 ... 1 V, 0 ... 5 V, 0 ... 10 V, 1 ... 5 V, scalable, min. load 1 kΩ Current: 4 ... 20 mA, 0 ... 20 mA, scalable, max. load 500 Ω
Accuracy of analog outputs at 20 °C	±0.1 % full scale for 0 ... 10 V and 0 ... 20 mA

Indigo202 model

Digital communications	RS-485, Modbus RTU
------------------------	--------------------

¹⁾ Vaisala Insight software for Windows® available at www.vaisala.com/insight.
²⁾ When used with the HMP7 probe, the minimum required power supply input is 18 V DC.

Compliance

Electromagnetic compatibility (EMC)	EN 61326-1, industrial environment
Compliance marks	CE, RCM

Mechanical specifications

Housing material	PC/ABS plastic
Display window material	PMMA plastic
Connection screw terminals	26 AWG ... 20 AWG
Weight	402 g (14.2 oz)
Dimensions (H×W×D)	149 × 135 × 43 mm (5.87 × 5.31 × 1.7 in)

Spare parts and accessories

USB-C connection cable (2 m, type C to A, for Insight PC software access) ¹⁾	273956
Probe connection cable, 1 m (3 ft 3 in)	INDIGOCABLE1M
Probe connection cable, H ₂ O ₂ compatible, 1 m (3 ft 3 in)	INDIGOCABLEHD1M5
Probe connection cable, 3 m (9 ft 11 in)	INDIGOCABLE3M
Probe connection cable, H ₂ O ₂ compatible, 3 m (9 ft 11 in)	INDIGOCABLEHD3M
Probe connection cable, 5 m (16 ft 5 in)	INDIGOCABLE5M
Probe connection cable, H ₂ O ₂ compatible, 5 m (16 ft 5 in)	INDIGOCABLEHD5M
Probe connection cable, 10 m (32 ft 10 in)	INDIGOCABLE10M
Probe connection cable, H ₂ O ₂ compatible, 10 m (32 ft 10 in)	INDIGOCABLEHD10M
Universal mains power supply with EU/US/UK/AUS plugs	INDIGOPOWER24V

¹⁾ Note that a USB-C cable is not included in Indigo200 deliveries by default. A generic USB-C cable (type C to A) can also be used.

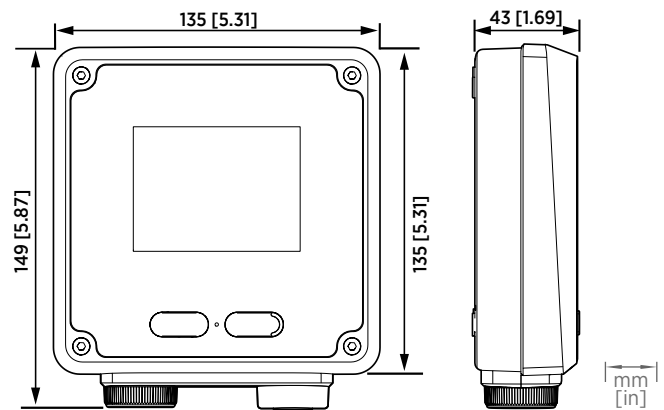

Indigo200 series dimensions



幸託有限公司
XIN TOP CORPORATION

TEL : (02)2598-1199

FAX : (02)2596-2331

E-mail : info@xintop.com

Website : www.xintop.com