



HMP3 General Purpose Humidity and Temperature Probe



Features

- Available with field-replaceable HUMICAP® R2 sensor
- RH accuracy up to 0.8 %RH
- Temperature accuracy up to 0.1 °C (0.18 °F)
- Temperature measurement range -40 ... +120 °C (-40 ... +248 °F)
- Sensor purge improves long-term stability and chemical resistance
- Modbus® RTU over RS-485
- Compatible with Vaisala Indigo products and Insight PC software

Vaisala HUMICAP® Humidity and Temperature Probe HMP3 is a general-purpose probe designed for various industrial processes. The probe structure allows for replacing the sensor without tools, making the probe suitable for applications such as paint booths and other industrial applications where periodic recalibration alone is not sufficient for maintaining the probe performance. Other applications include, for example, industrial HVAC systems, cleanrooms, and environmental chambers.

Designed for field maintenance

Probe design allows for several operating environments and flexible field maintenance. Filter and HUMICAP® R2 sensor element are field replaceable for applications that require frequent replacements. Calibration and adjustment of humidity measurement is also needed if the HUMICAP® R2 sensor is replaced. The following filter types are recommended for HMP3:

- Stainless steel mesh filter (12 µm mesh size) for typical applications such as air handling units
- Sintered stainless steel filter for applications where maximal protection from dust ingress is essential
- PPS plastic grid filter for best humidity response time

Sensor purge available with composite sensors

If purchased with a composite sensor instead of the field-replaceable HUMICAP® R2 sensor, HMP3 can use the sensor purge feature. In environments

with high concentrations of chemicals and cleaning agents, sensor purge helps to maintain measurement accuracy between calibration intervals.

Sensor purge involves heating the sensor to remove harmful chemicals. The function can be initiated manually or programmed to occur at set intervals.

Flexible connectivity

The probe can be used as a standalone digital Modbus RTU transmitter over an RS-485 serial bus, and it can also be connected to Indigo transmitters and the Indigo80 handheld indicator. For easy-to-use access to field calibration, device analytics, and configuration functionality, the probe can be connected to Vaisala Insight software for Windows®. For more information, see www.vaisala.com/insight.

Vaisala Indigo product family

Indigo transmitters extend the capabilities of Indigo-compatible measurement probes. The transmitters can display measurements on the spot as

well as transmit them to automation systems through analog signals, digital outputs, and relays. Cable length between probe and transmitter can be extended to up to 30 meters.

The Indigo80 handheld indicator is ideal for spot-checking and process monitoring, as well as for configuring, troubleshooting, calibrating, and adjusting the probe. For more information, see www.vaisala.com/indigo.



幸託有限公司
XIN TOP CORPORATION

TEL : (02)2598-1199
FAX : (02)2596-2331

E-mail : info@xintop.com
Website : www.xintop.com

Technical data

Measurement performance

Relative humidity

Measurement range	0 ... 100 %RH
Accuracy at +23 °C (+73.4 °F) ¹⁾	±0.8 %RH (0 ... 90 %RH)
Factory calibration uncertainty ²⁾	±0.5 %RH (0 ... 40 %RH) ±0.8 %RH (40 ... 95 %RH)
T ₆₃ response time	15 s
Sensor options	HUMICAP® R2 HUMICAP® R2C ³⁾ HUMICAP® 180VC ^{3) 4)}

Temperature

Sensor	Pt100 RTD Class F0.1 IEC 60751
Measurement range	-40 ... +120 °C (-40 ... +248 °F)
Accuracy ¹⁾	±0.1 °C (±0.18 °F)
Factory calibration uncertainty ²⁾	±0.1 °C (±0.18 °F) at +23 °C (+73.4 °F)

- 1) Defined against calibration reference. Including non-linearity, hysteresis, and repeatability.
 2) Defined as ±2 standard deviation limits. Small variations possible; see calibration certificate.
 3) Sensor purge feature available with this sensor.
 4) H₂O₂ resistant. With HUMICAP® 180VC sensor, accuracy is not specified below -20 °C (-4 °F) operating temperature.

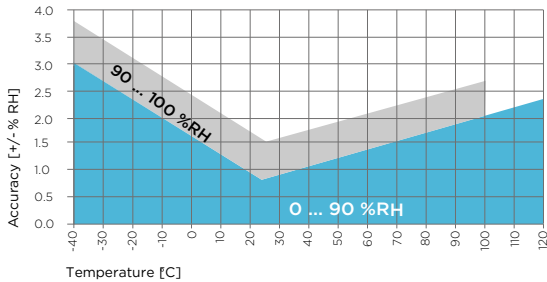

HMP3 humidity measurement accuracy as a function of temperature

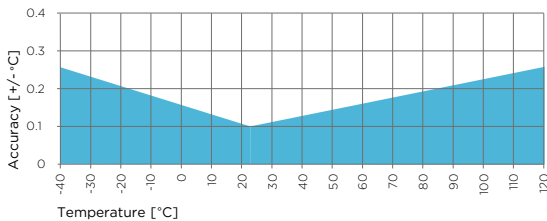

HMP3 temperature measurement accuracy over full range

Operating environment

Operating temperature of probe head	-40 ... +120 °C (-40 ... +248 °F)
Operating temperature of probe body	-40 ... +80 °C (-40 ... +176 °F)
Storage temperature	-40 ... +80 °C (-40 ... +176 °F)
Operating environment	Suitable for outdoor use
Measurement environment	For air, nitrogen, hydrogen, argon, helium, and oxygen ¹⁾
IP rating of probe body	IP66

1) Consult Vaisala if other chemicals are present. Consider safety regulations with flammable gases.

Inputs and outputs

Operating voltage	15 ... 30 V DC
Current consumption	10 mA typical, 500 mA max.
Digital output	RS-485, non-isolated
Protocols	Modbus RTU

Output parameters

Absolute humidity (g/m ³)	Relative humidity (%RH)
Absolute humidity at NTP (g/m ³)	Relative humidity (dew/frost) (%RH)
Dew point temperature (°C)	Temperature (°C)
Dew/frost point temperature (°C)	Water concentration (ppm _v)
Dew/frost point temperature at 1 atm (°C)	Water concentration (wet basis) (vol-%)
Dew point temperature at 1 atm (°C)	Water mass fraction (ppm _w)
Dew point temperature difference (°C)	Water vapor pressure (hPa)
Enthalpy (kJ/kg)	Water vapor saturation pressure (hPa)
Mixing ratio (g/kg)	Wet-bulb temperature (°C)

Compliance

EU directives and regulations	EMC Directive (2014/30/EU) RoHS Directive (2011/65/EU) amended by 2015/863
Electromagnetic compatibility (EMC)	EN 61326-1, industrial environment
Type approvals	DNV GL certificate no. TAA00002YT
Compliance marks	CE, China RoHS, RCM



Mechanical specifications

Connector	M12 5-pin A-coded male
Weight	302 g (10.65 oz)
Probe cable length	2 m (6.56 ft)
Materials	
Probe	AISI 316L
Probe body	AISI 316L
Cable jacket	FEP

Accessories

Duct installation kit for humidity probe	210697
Solar radiation shield DTR502B	DTR502B
Cable gland M20×1.5 with split seal	HMP247CG
Indigo USB adapter ¹⁾	USB2

1) Vaisala Insight software for Windows available at www.vaisala.com/insight.



幸託有限公司
XIN TOP CORPORATION

TEL : (02)2598-1199
FAX : (02)2596-2331

E-mail : info@xintop.com
Website : www.xintop.com

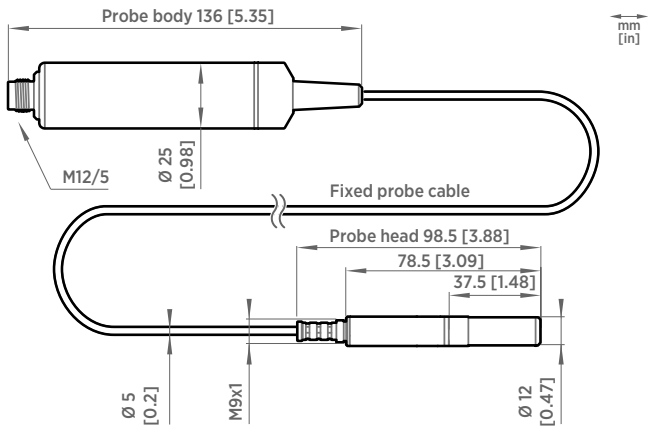

HMP3 probe dimensions

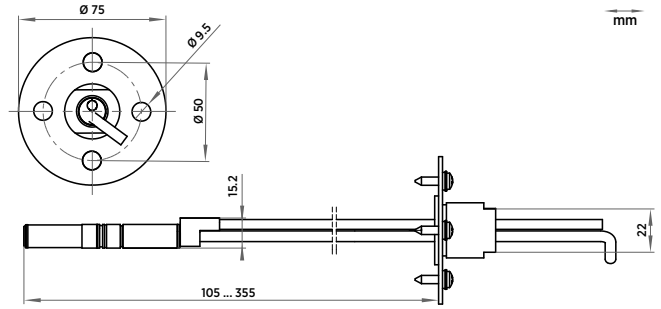

Duct installation kit 210697 dimensions with probe

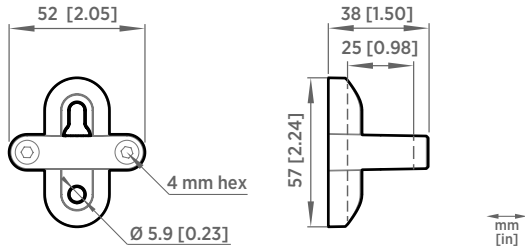

Probe holder ASM213582 dimensions



幸託有限公司
XIN TOP CORPORATION

TEL : (02)2598-1199
FAX : (02)2596-2331

E-mail : info@xintop.com
Website : www.xintop.com