

Super-mini Signal Conditioners Mini-M Series

SIGNAL TRANSMITTER

(PC programmable)

Functions & Features

- Converts DC input from a sensor into a standard process signal
- PC programmable
- CE marking
- UL approval

Typical Applications

- Isolation between control room and field instrumentation
- Ideal for quick spare part

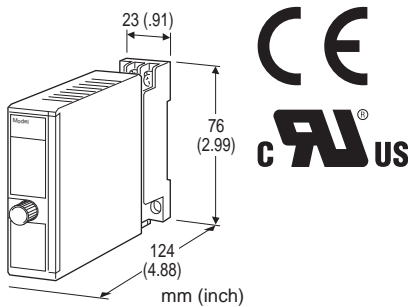

MODEL: M2XV2-[1][2]-[3][4]

ORDERING INFORMATION

- Code number: M2XV2-[1][2]-[3][4]
- Specify a code from below for each [1] through [4].
(e.g. M2XV2-S2Z1-R/CE/Q)
- Input range (e.g. 1 - 5 V DC)
 - Output range (e.g. 4 - 20 mA DC)
- Specify the specification for option code /Q
(e.g. /C01/S01)

[1] INPUT

Current

Z1: Range 0 - 50 mA DC (Input resistance 100 Ω)

Voltage

S1: Range -1 - +1 V DC (Input resistance 1 MΩ min.)

S2: Range -10 - +10 V DC (Input resistance 1 MΩ min.)

(Configurator software is used to change input over the described range of the selected suffix code. For changing out of this range (between S1 and S2), set the Input Range Selector on the side of unit before software adjustment. For a current input, set the Selector to the same setting as for S2 and use a receiving resistor.)

[2] OUTPUT

Current

Z1: Range 0 - 20 mA DC

Voltage

V1: Range -2.5 - +2.5 V DC

V2: Range -10 - +10 V DC

(Configurator software is used to change output over the described range of the selected suffix code. For changing out of this range, set the Output Range Selectors inside the unit before software adjustment.)

[3] POWER INPUT

AC Power

M2: 100 - 240 V AC (Operational voltage range 85 - 264 V, 47 - 66 Hz)

(90 - 264 V for UL)

DC Power

R: 24 V DC

(Operational voltage range 24 V ±10 %, ripple 10 %p-p max.)

P: 110 V DC

(Operational voltage range 85 - 150 V, ripple 10 %p-p max.)
(110 V ±10 % for UL)

[4] OPTIONS (multiple selections)

STANDARDS & APPROVALS (must be specified)

/N: Without CE or UL

/CE: CE marking

/UL: UL approval (CE marking)

OTHER OPTIONS

blank: none

/Q: Option other than the above (specify the specification)

(UL not available)

SPECIFICATIONS OF OPTION: Q (multiple selections)

COATING (For the detail, refer to M-System's web site.)

/C01: Silicone coating

/C02: Polyurethane coating

/C03: Rubber coating

TERMINAL SCREW MATERIAL

/S01: Stainless steel

RELATED PRODUCTS

- JX configurator connection kit (model: JXCON)

GENERAL SPECIFICATIONS

Construction: Plug-in

Connection: M3 screw terminals (torque 0.8 N·m)

Housing material: Flame-resistant resin (black)

Isolation: Input to output to power

Overrange output: Approx. -15 to +115 %



(Negative current output is not provided.)

Manual zero adjustments: -5 to +5 %
(factory setting: 0 %)

Manual span adjustments: 95 to 105 %
(factory setting: 100 %)

Programming: Downloaded from PC; input range, output range, zero and span, simulating output, etc.

Status indicator LED: Flashing patterns indicate different operating status of the transmitter.

Configurator connection: 2.5 dia. miniature jack;
RS-232C level

INPUT SPECIFICATIONS

• **DC Current:** Shunt resistor attached to the input terminals (0.5 W)

Operational range: 0 – 70 mA DC with 100 Ω, 0.5 W

Input range: 0 – 50 mA DC

Minimum span: 2 mA

Offset: Lower range can be any specific value within the input range provided that the minimum span is maintained.
If not specified, the input range is 4 – 20 mA DC.

• **DC Voltage**

Code S1 (narrow spans)

Operational range: -1.15 – +1.15 V DC

Input range: -1 – +1 V DC

Minimum span: 10 mV

Code S2 (wide spans)

Operational range: -11.5 – +11.5 V DC

Input range: -10 – +10 V DC

Minimum span: 100 mV

Offset: Lower range can be any specific value within the input range provided that the minimum span is maintained.
If not specified, the input range is shown below.

S1: 0 – 100 mV DC

S2: 1 – 5 V DC

OUTPUT SPECIFICATIONS

• **DC Current**

Operational range: 0 – 24 mA DC

Output range: 0 – 20 mA DC

Minimum span: 1 mA

Offset: Lower range can be any specific value within the output range provided that the minimum span is maintained.

Load resistance: Output drive 15 V max.
(e.g. 4 – 20 mA: 750 Ω [15 V / 20 mA])

If not specified, the output range is 4 – 20 mA DC.

• **DC VOLTAGE**

Code V1 (narrow spans)

Operational range: -3 – +3 V DC

Output range: -2.5 – +2.5 V DC

Minimum span: 250 mV

Code V2 (wide spans)

Operational range: -11.5 – +11.5 V DC

Output range: -10 – +10 V DC

Minimum span: 1 V

Offset: Lower range can be any specific value within the output range provided that the minimum span is maintained.

Load resistance: Output drive 1 mA max.
(e.g. 1 – 5 V: 5000 Ω [5 V / 1 mA])

If not specified, the output range is shown below.

V1: 0 – 1 V DC

V2: 1 – 5 V DC

INSTALLATION

Power Consumption

• **AC Power input:**

Approx. 3 VA at 100 V

Approx. 4 VA at 200 V

Approx. 5 VA at 264 V

• **DC Power input:** Approx. 2 W

Operating temperature: -30 to +60°C (-22 to +140°F)

Operating humidity: 30 to 90 %RH (non-condensing)

Mounting: Surface or DIN rail

Weight: 120 g (0.26 lbs)

PERFORMANCE in percentage of span

Accuracy: Input accuracy + output accuracy

Inversely proportional to the span.

Except the accuracy of input resistor.

Input accuracy: (% of max. input range)

-1 – +1 V : ±0.01 %

-10 – +10 V : ±0.01 %

0 – 50 mA : ±0.02 %

Output accuracy: ±0.04 % of max. output range

See CALCULATION EXAMPLES OF OVERALL ACURACY.

Temp. coefficient: ±0.015 %/°C (±0.008 %/°F) of max. span at -5 to +55°C [23 to 131°F]

Response time: ≤ 0.9 sec. (0 – 90 %)

Line voltage effect: ±0.1 % over voltage range

Insulation resistance: ≥ 100 MΩ with 500 V DC

Dielectric strength: 2000 V AC @1 minute (input to output to power to ground)

CALCULATION EXAMPLES OF OVERALL ACCURACY

[Example] Input Type -10 – +10 V, Input Range 1 – 5 V,

Output Type 0 – 20 mA, Output Range 4 – 20 mA

Max. Input Range (20 V) / Span (4 V) × 0.01 % = 0.05 %

Max. Output Range (20 mA) / Span (16 mA) × 0.04 %

= 0.05 %

Overall accuracy = 0.05 + 0.05 = ±0.10 %



STANDARDS & APPROVALS

CE conformity:

- EMC Directive (2004/108/EC)
- EN 61000-6-4 (EMI)
- EN 61000-6-2 (EMS)
- Low Voltage Directive (2006/95/EC)
- EN 61010-1
- Installation Category II
- Pollution Degree 2
- Max. operating voltage 300 V
- Input or output to power: Reinforced insulation
- Input to output: Basic insulation

Approval:

- UL/C-UL nonincendive Class I, Division 2, Groups A, B, C, and D hazardous locations (UL 1604, CAN/CSA-C22.2 No.213)
- UL/C-UL general safety requirements (UL 61010B-1, CAN/CSA-C22.2 No.1010-1)

EXTERNAL VIEW

FRONT VIEW (with cover open)

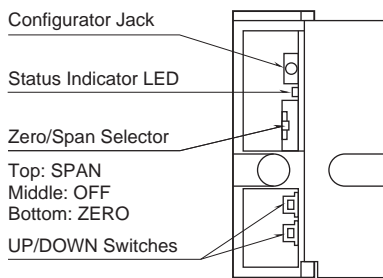

The front cover cannot be turned open by 180 deg. when there is no extra space between units.

RIGHT SIDE VIEW

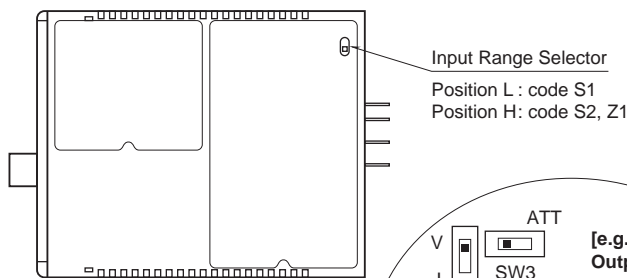

LEFT SIDE VIEW (with cover removed)

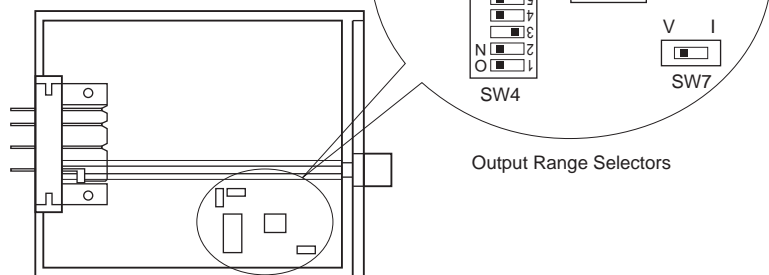

Refer to the instruction manual for detailed procedures.



DIMENSIONS unit: mm (inch)

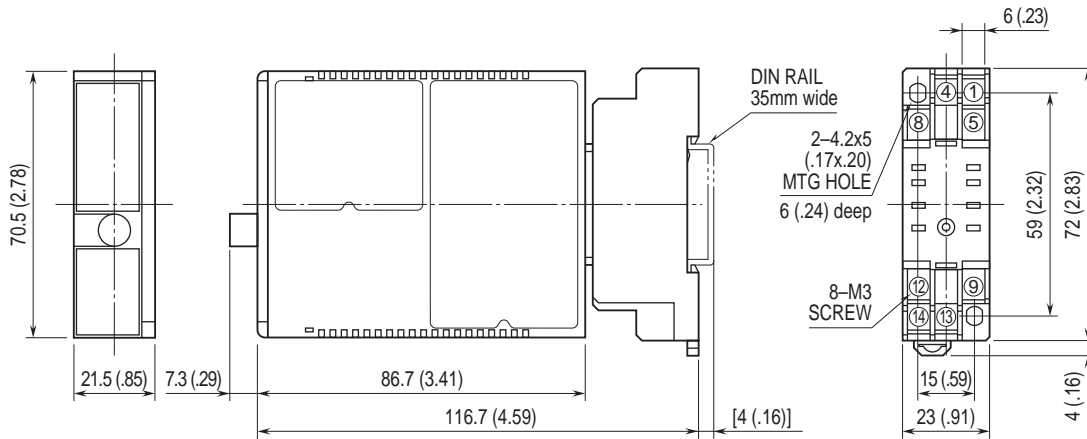

• When mounting, no extra space is needed between units.

TERMINAL ASSIGNMENTS unit: mm (inch)

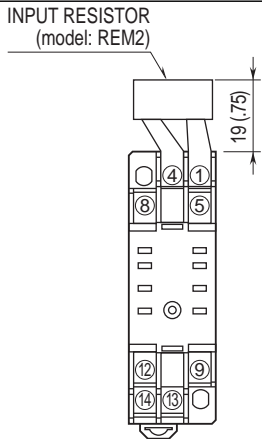

Input shunt resistor attached for current input.

SCHEMATIC CIRCUITRY & CONNECTION DIAGRAM

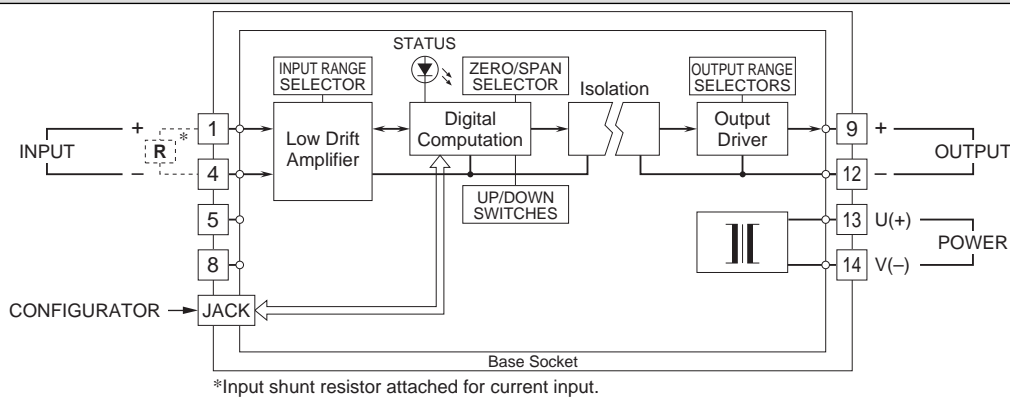

Specifications are subject to change without notice.