

Super-mini Signal Conditioners Mini-M Series

out of this range, set the Output Range Selectors inside the unit before software adjustment.)

POTENTIOMETER TRANSMITTER

(PC programmable)

Functions & Features

- Provides a DC output proportional to a potentiometer or slidewire position input
- PC programmable
- Potentiometer's zero/span points can be captured by on-site calibrations

Typical Applications

- Tank levels
- Positions: Compensating non-linear signal from the linking mechanism of a position detector

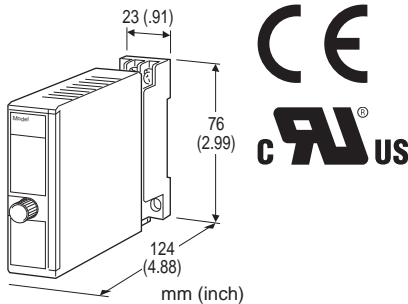

MODEL: M2XM2-1[1]-[2][3]

ORDERING INFORMATION

- Code number: M2XM2-1[1]-[2][3]
- Specify a code from below for each [1] through [3].
(e.g. M2XM2-1Z1-R/CE/Q)
- Input range (e.g. 0 - 500 Ω)
 - Output range (e.g. 4 - 20 mA DC)
 - Specify the specification for option code /Q (e.g. /C01/S01/SET)

INPUT POTENTIOMETER

1: Total resistance 100 Ω - 10 k Ω
(Configurator software is used to change input range (total resistance).)

[1] OUTPUT

Current

Z1: Range 0 - 20 mA DC

Voltage

V1: Range -2.5 - +2.5 V DC

V2: Range -10 - +10 V DC

(Configurator software is used to change output over the described range of the selected suffix code. For changing

[2] POWER INPUT

AC Power

M2: 100 - 240 V AC (Operational voltage range 85 - 264 V, 47 - 66 Hz)
(90 - 264 V for UL)

DC Power

R: 24 V DC
(Operational voltage range 24 V \pm 10 %, ripple 10 %p-p max.)
P: 110 V DC
(Operational voltage range 85 - 150 V, ripple 10 %p-p max.)
(110 V \pm 10 % for UL)

[3] OPTIONS (multiple selections)

Standards & Approvals (must be specified)

/N: Without CE or UL

/CE: CE marking

/UL: UL approval, CE marking

Other Options

blank: none

/Q: Option other than the above (specify the specification)
(UL not available)

SPECIFICATIONS OF OPTION: Q (multiple selections)

COATING (For the detail, refer to M-System's web site.)

/C01: Silicone coating

/C02: Polyurethane coating

/C03: Rubber coating

TERMINAL SCREW MATERIAL

/S01: Stainless steel

EX-FACTORY SETTING

/SET: Preset according to the Ordering Information Sheet
(No. ESU-5093)

RELATED PRODUCTS

- JX configurator connection kit (model: JXCON)

GENERAL SPECIFICATIONS

Construction: Plug-in

Connection: M3 screw terminals (torque 0.8 N·m)

Screw terminal: Chromated steel (standard) or stainless steel

Housing material: Flame-resistant resin (black)

Isolation: Input to output to power

Overrange output: Approx. -15 to +115 %
(Negative current output is not provided.)

Manual zero adjustments: -5 to +5 %
(factory setting: 0 %)



Manual span adjustments: 95 to 105 %

(factory setting: 100 %)

Programming: Downloaded from PC; linearization (100 points), input range (total resistance), output range, zero and span, simulating output, etc.

Burnout: Upscale standard; downscale or no burnout optional by programming

Status indicator LED: Blinking patterns indicate different operating status of the transmitter.

Configurator connection: 2.5 dia. miniature jack; RS-232-C level

INPUT SPECIFICATIONS

•Potentiometer: 100 Ω - 10 kΩ

Range : Minimum span

0 - 100 Ω : 2.5 Ω

0 - 300 Ω : 3.0 Ω

0 - 1000 Ω : 10 Ω

0 - 10 kΩ : 10 Ω

Excitation: ≤ 0.5 V DC at 1000 Ω

OUTPUT SPECIFICATIONS

■ DC Current

Operational range: 0 - 24 mA DC

Output range: 0 - 20 mA DC

Minimum span: 1 mA

Offset: Lower range can be any specific value within the output range provided that the minimum span is maintained.

Load resistance: Output drive 15 V max.

(e.g. 4 - 20 mA: 750 Ω [15 V / 20 mA])

If not specified, the output range is 4 - 20 mA DC.

■ DC Voltage

Code V1 (narrow spans)

Operational range: -3 - +3 V DC

Output range: -2.5 - +2.5 V DC

Minimum span: 250 mV

Code V2 (wide spans)

Operational range: -11.5 - +11.5 V DC

Output range: -10 - +10 V DC

Minimum span: 1 V

Offset: Lower range can be any specific value within the output range provided that the minimum span is maintained.

Load resistance: Output drive 1 mA max.

(e.g. 1 - 5 V: 5000 Ω [5 V / 1 mA])

If not specified, the output range is shown below.

V1: 0 - 1 V DC

V2: 1 - 5 V DC

INSTALLATION

Power Consumption

•AC:

Approx. 3 VA at 100 V

Approx. 4 VA at 200 V

Approx. 5 VA at 264 V

•DC: Approx. 2 W

Operating temperature: -30 to +60°C (-22 to +140°F)

Operating humidity: 30 to 90 %RH (non-condensing)

Mounting: Surface or DIN rail

Weight: 120 g (0.26 lb)

PERFORMANCE in percentage of span

Accuracy: Input accuracy + output accuracy

Inversely proportional to the span.

Input accuracy: (% of max. input range)

(Range)

0 - 100 Ω : ±0.02 %

0 - 300 Ω : ±0.02 %

0 - 1000 Ω : ±0.01 %

0 - 10 kΩ : ±0.02 %

Output accuracy: ±0.04 % of max. output range

Temp. coefficient: ±0.015 %/°C (±0.008 %/°F) of max. span at -5 to +55°C [23 to 131°F]

Response time: ≤ 0.9 sec. (0 - 90 %)

Burnout response time: ≤ 30 sec.

Line voltage effect: ±0.1 % over voltage range

Insulation resistance: ≥ 100 MΩ with 500 V DC

Dielectric strength: 2000 V AC @1 minute (input to output to power to ground)

CALCULATION EXAMPLES OF OVERALL ACCURACY

[Example] Input Type 0 - 1000 Ω, Input Range 250 - 750 Ω

, Output Type 0 - 20 mA, Output Range 4 - 20 mA

Max. Input Range (1000 Ω) ÷ Span (500 Ω) × 0.01 %
= 0.02 %

Max. Output Range (20 mA) ÷ Span (16 mA) × 0.04 %
= 0.05 %

Overall accuracy = 0.02 % + 0.05 % = ±0.07 %

STANDARDS & APPROVALS

CE conformity:

EMC Directive (2004/108/EC)

EMI EN 61000-6-4: 2007

EMS EN 61000-6-2: 2005

Low Voltage Directive (2006/95/EC)

EN 61010-1: 2001

Installation Category II

Pollution Degree 2

Input or output to power: Reinforced insulation (300 V)

Input to output: Basic insulation (300 V)



Approval:

UL/C-UL nonincendive Class I, Division 2,
 Groups A, B, C, and D
 (ANSI/ISA-12.12.01:2011, CAN/CSA-C22.2 No.213:1987)
 UL/C-UL general safety requirements
 (UL 61010B-1:2003, CAN/CSA-C22.2 No.61010-1:1992)

EXTERNAL VIEW

FRONT VIEW (with cover open)

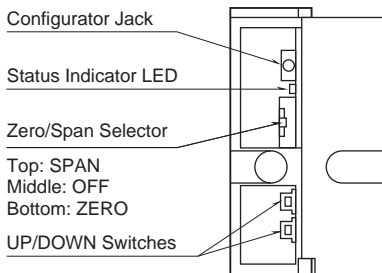

LEFT SIDE VIEW (with cover removed)

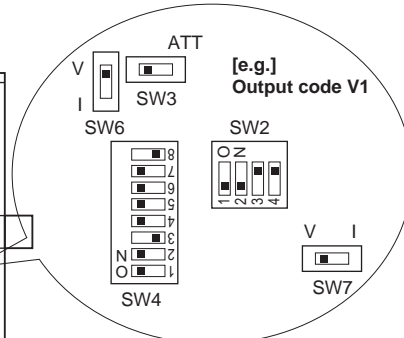
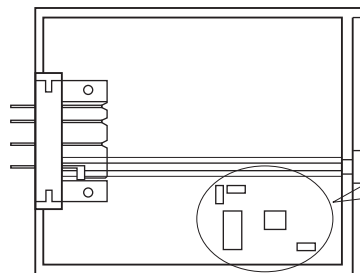

Output Range Selectors

The front cover cannot be turned open by 180 deg. when there is no extra space between units.

Refer to the instruction manual for detailed procedures.

DIMENSIONS unit: mm (inch)

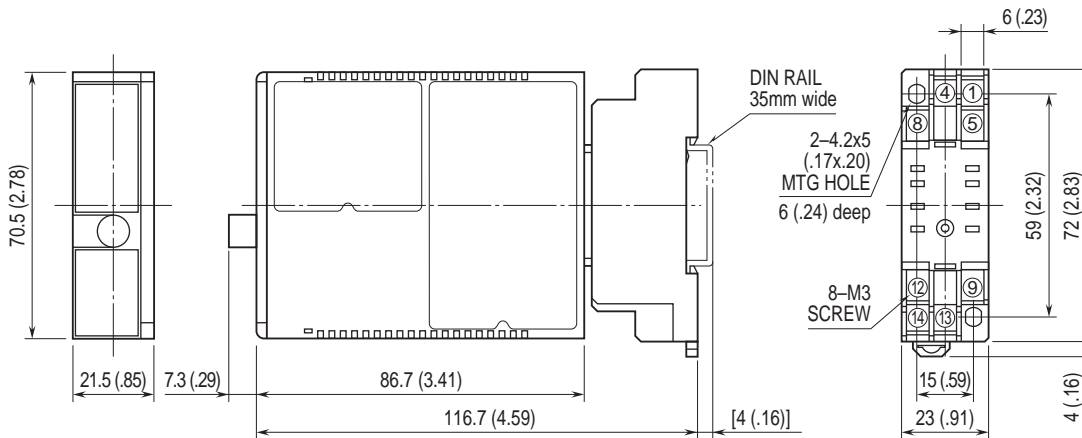

• When mounting, no extra space is needed between units.

SCHEMATIC CIRCUITRY & CONNECTION DIAGRAM

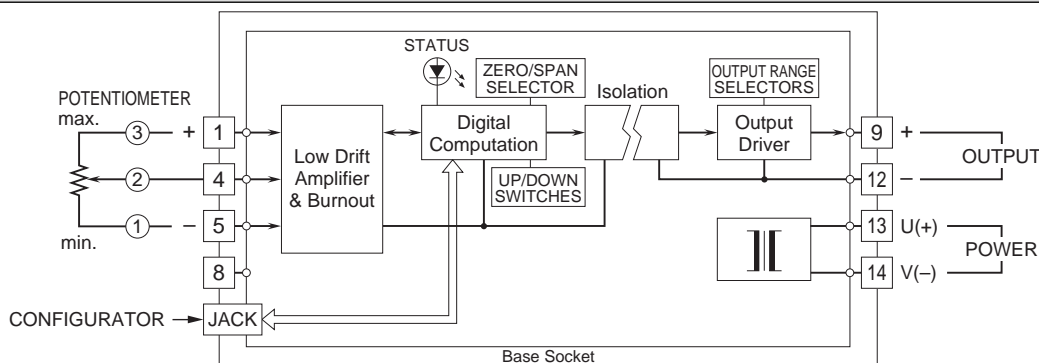



Specifications are subject to change without notice.

