

Super-mini Signal Conditioners Mini-M Series

HIGH/LOW SELECTOR

(with simple loop test output)

Functions & Features

- Monitors two DC input signals and transmitting an output signal proportional to the higher or lower input
- Simple loop test output (0, 50, 100 %)
- High-density mounting
- CE marking

Typical Applications

- Selecting greater flow, pressure, etc. for control
- Heating control by multiple T/C's on a furnace

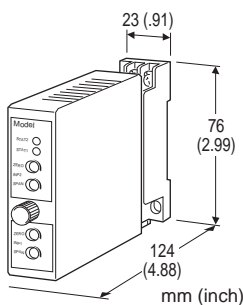

MODEL: M2SES2-[1][2]-[3][4]

ORDERING INFORMATION

- Code number: M2SES2-[1][2]-[3][4]
- Specify a code from below for [1] and [4]. (e.g. M2SES2-AA-M2/CE/Q)
- Special output range (For codes Z & 0)
- Specify the specification for option code /Q (e.g. /C01/S01)

[1] INPUT

Current

- A: 4 - 20 mA DC (Input resistance 250 Ω)
- B: 2 - 10 mA DC (Input resistance 500 Ω)
- C: 1 - 5 mA DC (Input resistance 1000 Ω)
- H: 10 - 50 mA DC (Input resistance 100 Ω)

Voltage

- 6: 1 - 5 V DC (Input resistance 1 M Ω min.)

[2] OUTPUT

Current

- A: 4 - 20 mA DC (Load resistance 750 Ω max.)
- B: 2 - 10 mA DC (Load resistance 1500 Ω max.)
- C: 1 - 5 mA DC (Load resistance 3000 Ω max.)
- D: 0 - 20 mA DC (Load resistance 750 Ω max.)

- E: 0 - 16 mA DC (Load resistance 900 Ω max.)
- F: 0 - 10 mA DC (Load resistance 1500 Ω max.)
- G: 0 - 1 mA DC (Load resistance 15 k Ω max.)
- Z: Specify current (See OUTPUT SPECIFICATIONS)

Voltage

- 1: 0 - 10 mV DC (Load resistance 10 k Ω min.)
- 2: 0 - 100 mV DC (Load resistance 100 k Ω min.)
- 3: 0 - 1 V DC (Load resistance 1000 Ω min.)
- 4: 0 - 10 V DC (Load resistance 10 k Ω min.)
- 5: 0 - 5 V DC (Load resistance 5000 Ω min.)
- 6: 1 - 5 V DC (Load resistance 5000 Ω min.)
- 4W: -10 - +10 V DC (Load resistance 10 k Ω min.)
- 5W: -5 - +5 V DC (Load resistance 5000 Ω min.)
- 0: Specify voltage (See OUTPUT SPECIFICATIONS)

[3] POWER INPUT

AC Power

- M: 85 - 264 V AC (Operational voltage range 85 - 264 V, 47 - 66 Hz)

(Select '/N' for 'Standards & Approvals' code.)

- M2: 100 - 240 V AC (Operational voltage range 85 - 264 V, 47 - 66 Hz)

DC Power

- R: 24 V DC (Operational voltage range 24 V \pm 10 %, ripple 10 %p-p max.)
- R2: 11 - 27 V DC (Operational voltage range 11 - 27 V, ripple 10 %p-p max.) (Select '/N' for 'Standards & Approvals' code.)
- P: 110 V DC (Operational voltage range 85 - 150 V, ripple 10 %p-p max.)

[4] OPTIONS (multiple selections)

STANDARDS & APPROVALS (must be specified)

/N: Without CE or UL

/CE: CE marking

OTHER OPTIONS

blank: none

/Q: Option other than the above (specify the specification)

SPECIFICATIONS OF OPTION: Q (multiple selections)

COATING (For the detail, refer to M-System's web site.)

/C01: Silicone coating

/C02: Polyurethane coating

/C03: Rubber coating

TERMINAL SCREW MATERIAL

/S01: Stainless steel

GENERAL SPECIFICATIONS

Construction: Plug-in

Connection: M3 screw terminals (torque 0.8 N·m)



Housing material: Flame-resistant resin (black)
Isolation: Input to output to power
Overrange output: Approx. -10 to +120 % at 1 - 5 V
Input zero adjustments: -2 to +2 % (front)
Input span adjustments: 98 to 102 % (front)
DIP switch setting: Selecting output options
Status indicator LED 1: Green LED; indicates the transmitter's function mode (Refer to the instruction manual.)
Status indicator LED 2: Orange LED; indicates the transmitter's function mode (Refer to the instruction manual.)

EN 61000-6-4 (EMI)
EN 61000-6-2 (EMS)
Low Voltage Directive (2006/95/EC)
EN 61010-1
Installation Category II
Pollution Degree 2
Max. operating voltage 300 V
Input or output to power: Reinforced insulation
Input to output: Basic insulation

INPUT SPECIFICATIONS

- **DC Current:** Input resistor incorporated

OUTPUT SPECIFICATIONS

- **DC Current:** 0 - 20 mA DC
Minimum span: 1 mA
Offset: Max. 1.5 times span
Load resistance: Output drive 15 V max.
- **DC Voltage:** -10 - +12 V DC
Minimum span: 5 mV
Offset: Max. 1.5 times span
Load resistance: Output drive 1 mA max.; at ≥ 0.5 V

INSTALLATION

Power Consumption
• **AC Power input:**
Approx. 3 VA at 100 V
Approx. 4 VA at 200 V
Approx. 5 VA at 264 V
• **DC Power input:** Approx. 3 W
Operating temperature: -5 to +55°C (23 to 131°F)
Operating humidity: 30 to 90 %RH (non-condensing)
Mounting: Surface or DIN rail
Weight: 150 g (0.33 lbs)

PERFORMANCE in percentage of span

Accuracy: ± 0.2 %
Temp. coefficient: ± 0.015 %/°C (± 0.008 %/°F)
Response time: ≤ 0.5 sec. (0 - 90 %)
Line voltage effect: ± 0.1 % over voltage range
Insulation resistance: ≥ 100 M Ω with 500 V DC
Dielectric strength: 2000 V AC @1 minute (input to output to power to ground)

STANDARDS & APPROVALS

CE conformity:
EMC Directive (2004/108/EC)



EXTERNAL VIEW

FRONT VIEW

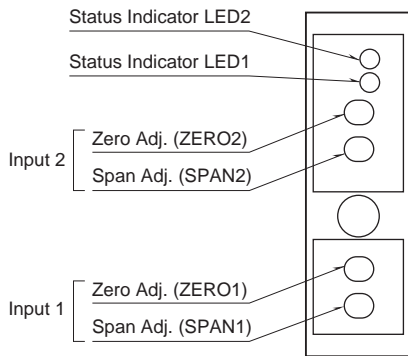

SIDE VIEW

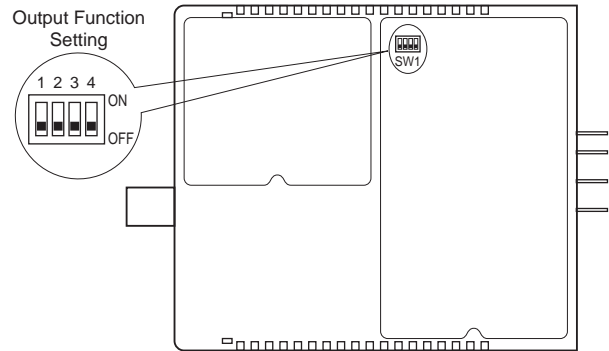

Refer to the instruction manual for detailed procedures.

DIMENSIONS unit: mm (inch)

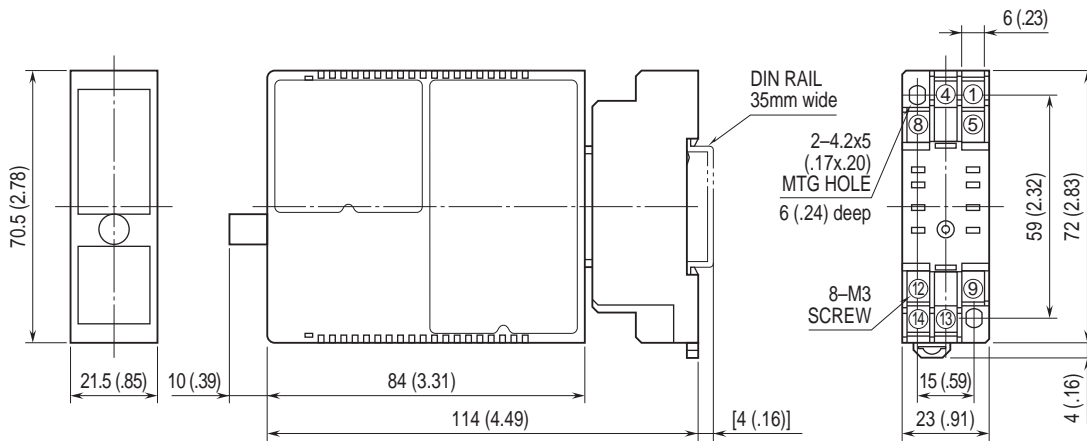

• When mounting, no extra space is needed between units.

SCHEMATIC CIRCUITRY & CONNECTION DIAGRAM

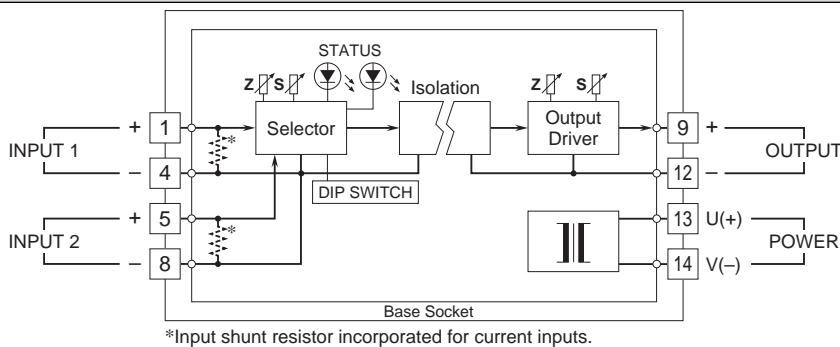

Specifications are subject to change without notice.