

## Super-mini Signal Conditioners Mini-M Series

### HIGH/LOW SELECTOR

#### Functions & Features

- Monitors two DC input signals and transmits an output signal proportional to the higher or lower input
- CE marking
- UL approval

#### Typical Applications

- Selecting greater flow, pressure, etc. for control
- Heating control based on the highest temperature among several T/C's on a furnace

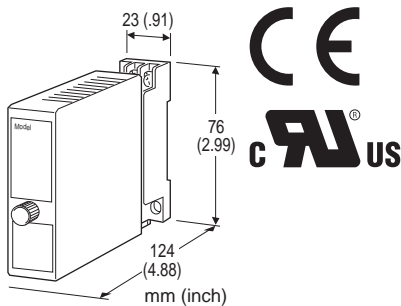

### MODEL: M2SES-[1][2][3]-[4][5]

#### ORDERING INFORMATION

- Code number: M2SES-[1][2][3]-[4][5]
- Specify a code from below for [1] and [5].  
(e.g. M2SES-2AA-M2/CE/Q)
- Special output range (For codes Z & 0)
  - Specify the specification for option code /Q  
(e.g. /C01/S01)

#### [1] SELECTING FUNCTION

- 1: Low input
- 2: High input

#### [2] INPUT

##### Current

- A: 4 - 20 mA DC (Input resistance 250  $\Omega$ )
- B: 2 - 10 mA DC (Input resistance 500  $\Omega$ )
- C: 1 - 5 mA DC (Input resistance 1000  $\Omega$ )
- H: 10 - 50 mA DC (Input resistance 100  $\Omega$ )

##### Voltage

- 6: 1 - 5 V DC (Input resistance 1 M $\Omega$  min.)

#### [3] OUTPUT

##### Current

- A: 4 - 20 mA DC (Load resistance 750  $\Omega$  max.)
- B: 2 - 10 mA DC (Load resistance 1500  $\Omega$  max.)
- C: 1 - 5 mA DC (Load resistance 3000  $\Omega$  max.)
- D: 0 - 20 mA DC (Load resistance 750  $\Omega$  max.)
- E: 0 - 16 mA DC (Load resistance 900  $\Omega$  max.)
- F: 0 - 10 mA DC (Load resistance 1500  $\Omega$  max.)
- G: 0 - 1 mA DC (Load resistance 15 k $\Omega$  max.)
- Z: Specify current (See OUTPUT SPECIFICATIONS)

##### Voltage

- 1: 0 - 10 mV DC (Load resistance 10 k $\Omega$  min.)
- 2: 0 - 100 mV DC (Load resistance 100 k $\Omega$  min.)
- 3: 0 - 1 V DC (Load resistance 1000  $\Omega$  min.)
- 4: 0 - 10 V DC (Load resistance 10 k $\Omega$  min.)
- 5: 0 - 5 V DC (Load resistance 5000  $\Omega$  min.)
- 6: 1 - 5 V DC (Load resistance 5000  $\Omega$  min.)
- 4W: -10 - +10 V DC (Load resistance 10 k $\Omega$  min.)
- 5W: -5 - +5 V DC (Load resistance 5000  $\Omega$  min.)
- 0: Specify voltage (See OUTPUT SPECIFICATIONS)

#### [4] POWER INPUT

##### AC Power

- M: 85 - 264 V AC (Operational voltage range 85 - 264 V, 47 - 66 Hz)

(Select '/N' for 'Standards & Approvals' code.)

- M2: 100 - 240 V AC (Operational voltage range 85 - 264 V, 47 - 66 Hz)

(90 - 264 V for UL)

##### DC Power

- R: 24 V DC  
(Operational voltage range 24 V  $\pm$ 10 %, ripple 10 %p-p max.)

- R2: 11 - 27 V DC

(Operational voltage range 11 - 27 V, ripple 10 %p-p max.)  
(Select '/N' for 'Standards & Approvals' code.)

- P: 110 V DC

(Operational voltage range 85 - 150 V, ripple 10 %p-p max.)  
(110 V  $\pm$ 10 % for UL)

#### [5] OPTIONS (multiple selections)

##### STANDARDS & APPROVALS (must be specified)

/N: Without CE or UL

/CE: CE marking

/UL: UL approval (CE marking)

##### OTHER OPTIONS

blank: none

/Q: Option other than the above (specify the specification)  
(UL not available)



## SPECIFICATIONS OF OPTION: Q (multiple selections)

**COATING (For the detail, refer to M-System's web site.)**

/C01: Silicone coating

/C02: Polyurethane coating

/C03: Rubber coating

**TERMINAL SCREW MATERIAL**

/S01: Stainless steel

## GENERAL SPECIFICATIONS

**Construction:** Plug-in

**Connection:** M3 screw terminals (torque 0.8 N·m)

**Housing material:** Flame-resistant resin (black)

**Isolation:** Input to output to power

**Overrange output:** Approx. -10 to +120 % at 1 - 5 V

**Selecting operation:** Automatic

## INPUT SPECIFICATIONS

• **DC Current:** Input resistor incorporated

## OUTPUT SPECIFICATIONS

• **DC Current:** 0 - 20 mA DC

**Minimum span:** 1 mA

**Offset:** Max. 1.5 times span

**Load resistance:** Output drive 15 V max.

• **DC Voltage:** -10 - +12 V DC

**Minimum span:** 5 mV

**Offset:** Max. 1.5 times span

**Load resistance:** Output drive 1 mA max.; at  $\geq 0.5$  V

## INSTALLATION

**Power Consumption**

• **AC Power input:**

Approx. 3 VA at 100 V

Approx. 4 VA at 200 V

Approx. 5 VA at 264 V

• **DC Power input:** Approx. 3 W

**Operating temperature:** -5 to +55°C (23 to 131°F)

**Operating humidity:** 30 to 90 %RH (non-condensing)

**Mounting:** Surface or DIN rail

**Weight:** 150 g (0.33 lbs)

## PERFORMANCE in percentage of span

**Accuracy:**  $\pm 0.2$  %

**Selecting sensitivity:** 0.5%

**Temp. coefficient:**  $\pm 0.015$  %/°C ( $\pm 0.008$  %/°F)

**Response time:**  $\leq 0.5$  sec. (0 - 90 %)

**Line voltage effect:**  $\pm 0.1$  % over voltage range

**Insulation resistance:**  $\geq 100$  M $\Omega$  with 500 V DC

**Dielectric strength:**

1000 V AC @1 minute (input to output)

2000 V AC @1 minute (input or output to power to ground)

## STANDARDS & APPROVALS

**CE conformity:**

EMC Directive (2004/108/EC)

EN 61000-6-4 (EMI)

EN 61000-6-2 (EMS)

Low Voltage Directive (2006/95/EC)

EN 61010-1

Installation Category II

Pollution Degree 2

Max. operating voltage 300 V

Input or output to power: Reinforced insulation

Input to output: Basic insulation

**Approval:**

UL/C-UL nonincendive Class I, Division 2,

Groups A, B, C, and D hazardous locations

(UL 1604, CAN/CSA-C22.2 No.213)

UL/C-UL general safety requirements

(UL 61010B-1, CAN/CSA-C22.2 No.1010-1)



## DIMENSIONS unit: mm (inch)

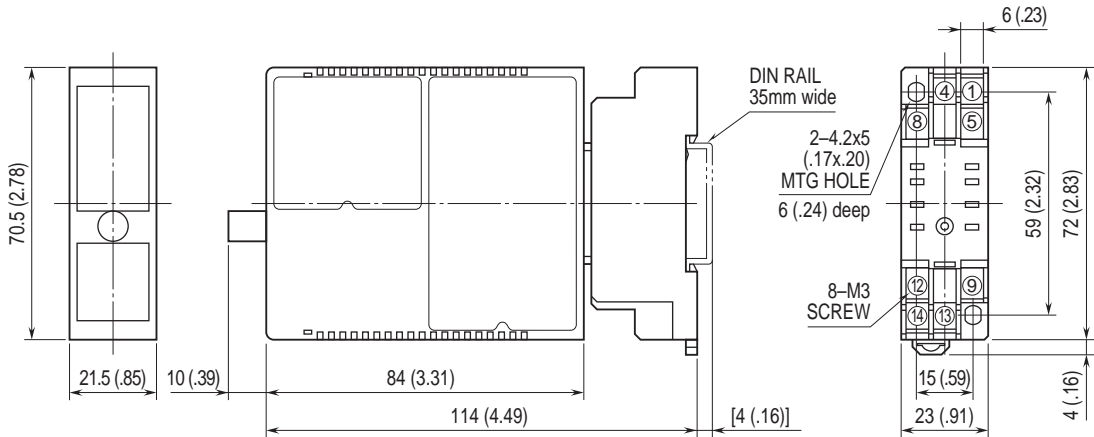

• When mounting, no extra space is needed between units.

## SCHEMATIC CIRCUITRY & CONNECTION DIAGRAM

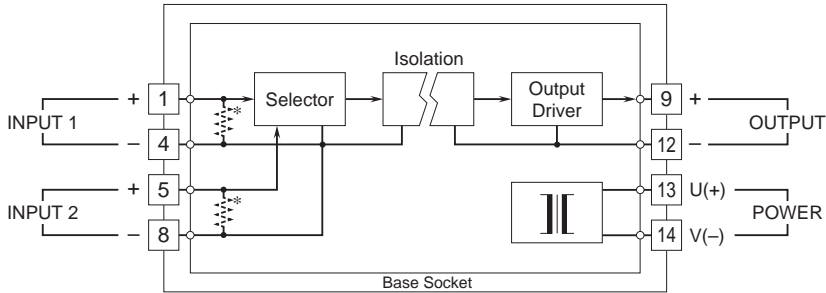

\*Input shunt resistor incorporated for current inputs.



Specifications are subject to change without notice.