

Super-mini Signal Conditioners Mini-M Series

RESISTANCE/RESISTANCE CONVERTER

Functions & Features

- Accepts a resistance input from an RTD and provides a multiplied resistance value
- High-density mounting

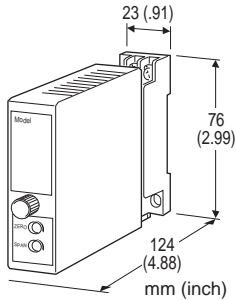

MODEL: M2RR-[1]-[2][3]

ORDERING INFORMATION

- Code number: M2RR-[1]-[2][3]
Specify a code from below for each [1] through [3].
(e.g. M2RR-5-M/Q)
- Input resistance range (e.g. 100 - 150 Ω)
- Specify the specification for option code /Q
(e.g. /C01/S01)

[1] I/O RATIO

(n = Output / Input)

2 : n = 2

5 : n = 5

10 : n = 10

0: Specify 'n' (≥ 1.20)

[2] POWER INPUT

AC Power

M: 85 - 264 V AC (Operational voltage range 85 - 264 V, 47 - 66 Hz)

DC Power

R2: 11 - 27 V DC

(Operational voltage range 11 - 27 V, ripple 10 %p-p max.)

P: 110 V DC

(Operational voltage range 85 - 150 V, ripple 10 %p-p max.)

[3] OPTIONS

OTHER OPTIONS

blank: none

/Q: Option other than the above (specify the specification)

SPECIFICATIONS OF OPTION: Q (multiple selections)

COATING (For the detail, refer to M-System's web site.)

/C01: Silicone coating

/C02: Polyurethane coating

/C03: Rubber coating

TERMINAL SCREW MATERIAL

/S01: Stainless steel

GENERAL SPECIFICATIONS

Construction: Plug-in

Connection: M3 screw terminals (torque 0.8 N·m)

Housing material: Flame-resistant resin (black)

Isolation: Input or output to power (non-isolated between input and output)

Zero adjustment: $\pm 2\%$ of the output resistance (measuring current ≤ 2 mA DC)

Span (gain) adjustment: $\pm 5\%$ of the output resistance

I/O ratio: 1.20 - 100.00

INPUT SPECIFICATIONS

Resistance: 40 Ω to 5 k Ω

OUTPUT SPECIFICATIONS

Resistance: 80 Ω to 10 k Ω

Maximum measuring voltage: 12 V DC

Minimum measuring current: 1 mA DC

Maximum measuring current: 20 mA DC

Note: AC measurement is unable.

INSTALLATION

Power Consumption

AC Power input

Approx. 1.0 VA at 100 V

Approx. 2.5 VA at 200 V

Approx. 3.5 VA at 264 V

• DC Power input: Approx. 0.5 W

Operating temperature: -5 to +55°C (23 to 131°F)

Operating humidity: 30 to 90 %RH (non-condensing)

Mounting: Surface or DIN rail

Weight: 150 g (0.33 lbs)

PERFORMANCE based on the resistance output

Accuracy: $\pm 0.1\%$ or 0.1 Ω , whichever is greater.

Temp. coefficient: $\pm 0.04\%$ /°C ($\pm 0.02\%$ /°F)

(n = 5, Rin = 100 Ω , Is = 7 mA)

The following equation is applied for other cases:

Temp. coefficient (%/°C) = $(5 \times n) / (Rin (\Omega) \times Is (mA))$

n = I/O ratio

Rin = Input resistance

Is = Measuring current



Response time: ≤ 50 msec. (0 - 90 %)

Line voltage effect: ± 0.1 % over voltage range

Insulation resistance: ≥ 100 M Ω with 500 V DC

Dielectric strength: 2000 V AC @1 minute (input or output to power to ground)

DIMENSIONS unit: mm (inch)

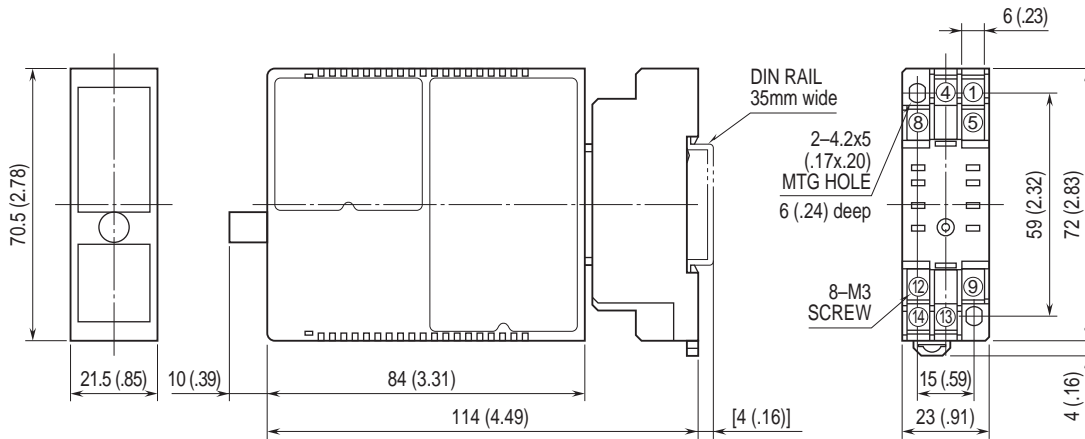

• When mounting, no extra space is needed between units.

SCHEMATIC CIRCUITRY & CONNECTION DIAGRAM

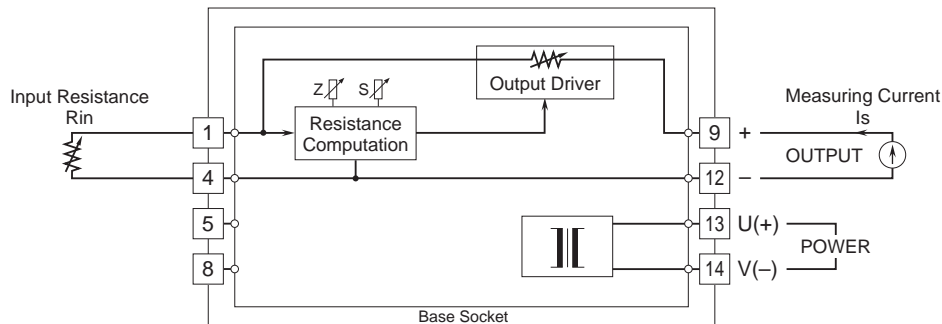

Specifications are subject to change without notice.