

Super-mini Signal Conditioners Mini-M Series

PEAK HOLD

(with simple loop test output)

Functions & Features

- Track mode: the output follows proportionally to the input
- Peak-hold mode: responds only to an increasing signal, holding the maximum value until a higher signal or a command to reset is received
- Valley hold and peak-to-peak mode selectable
- Simple loop test output (0, 50, 100%)

Typical Applications

- Monitoring peak power consumption
- Monitoring the highest or lowest temperature

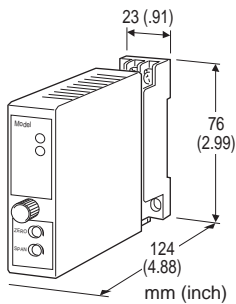

MODEL: M2PHS2[1]-[2][3]-[4][5]

ORDERING INFORMATION

- Code number: M2PHS2[1]-[2][3]-[4][5]
Specify a code from below for each [1] through [5].
(e.g. M2PHS2H-6A-M2/CE/Q)
- Special input and output ranges (For codes Z & 0)
- Specify the specification for option code /Q
(e.g. /C01/S01)

[1] HOLD FUNCTION

H: Peak hold

L: Valley hold

W: Peak-to-peak hold

[2] INPUT

Current

- A:** 4 - 20 mA DC (Input resistance 250 Ω)
- A1:** 4 - 20 mA DC (Input resistance 50 Ω)
- B:** 2 - 10 mA DC (Input resistance 500 Ω)
- C:** 1 - 5 mA DC (Input resistance 1000 Ω)
- D:** 0 - 20 mA DC (Input resistance 50 Ω)
- E:** 0 - 16 mA DC (Input resistance 62.5 Ω)

- F:** 0 - 10 mA DC (Input resistance 100 Ω)
- G:** 0 - 1 mA DC (Input resistance 1000 Ω)
- H:** 10 - 50 mA DC (Input resistance 100 Ω)
- J:** 0 - 10 μA DC (Input resistance 1000 Ω)
- K:** 0 - 100 μA DC (Input resistance 1000 Ω)
- GW:** -1 - +1 mA DC (Input resistance 1000 Ω)
- FW:** -10 - +10 mA DC (Input resistance 100 Ω)
- Z:** Specify current (See INPUT SPECIFICATIONS)

Voltage

- 1:** 0 - 10 mV DC (Input resistance 10 kΩ min.)
- 15:** 0 - 50 mV DC (Input resistance 10 kΩ min.)
- 16:** 0 - 60 mV DC (Input resistance 10 kΩ min.)
- 2:** 0 - 100 mV DC (Input resistance 100 kΩ min.)
- 3:** 0 - 1 V DC (Input resistance 1 MΩ min.)
- 4:** 0 - 10 V DC (Input resistance 1 MΩ min.)
- 5:** 0 - 5 V DC (Input resistance 1 MΩ min.)
- 6:** 1 - 5 V DC (Input resistance 1 MΩ min.)
- 4W:** -10 - +10 V DC (Input resistance 1 MΩ min.)
- 5W:** -5 - +5 V DC (Input resistance 1 MΩ min.)
- 0:** Specify voltage (See INPUT SPECIFICATIONS)

[3] OUTPUT

Current

- A:** 4 - 20 mA DC (Load resistance 750 Ω max.)
- B:** 2 - 10 mA DC (Load resistance 1500 Ω max.)
- C:** 1 - 5 mA DC (Load resistance 3000 Ω max.)
- D:** 0 - 20 mA DC (Load resistance 750 Ω max.)
- E:** 0 - 16 mA DC (Load resistance 900 Ω max.)
- F:** 0 - 10 mA DC (Load resistance 1500 Ω max.)
- G:** 0 - 1 mA DC (Load resistance 15 kΩ max.)
- Z:** Specify current (See OUTPUT SPECIFICATIONS)

Voltage

- 1:** 0 - 10 mV DC (Load resistance 10 kΩ min.)
- 2:** 0 - 100 mV DC (Load resistance 100 kΩ min.)
- 3:** 0 - 1 V DC (Load resistance 1000 Ω min.)
- 4:** 0 - 10 V DC (Load resistance 10 kΩ min.)
- 5:** 0 - 5 V DC (Load resistance 5000 Ω min.)
- 6:** 1 - 5 V DC (Load resistance 5000 Ω min.)
- 4W:** -10 - +10 V DC (Load resistance 10 kΩ min.)
- 5W:** -5 - +5 V DC (Load resistance 5000 Ω min.)
- 0:** Specify voltage (See OUTPUT SPECIFICATIONS)

[4] POWER INPUT

AC Power

M: 85 - 264 V AC (Operational voltage range 85 - 264 V, 47 - 66 Hz)

(Select '/N' for 'Standards & Approvals' code.)

M2: 100 - 240 V AC (Operational voltage range 85 - 264 V, 47 - 66 Hz)

DC Power

R: 24 V DC



(Operational voltage range 24 V \pm 10 %, ripple 10 %p-p max.)

R2: 11 - 27 V DC

(Operational voltage range 11 - 27 V, ripple 10 %p-p max.)

(Select '/N' for 'Standards & Approvals' code.)

P: 110 V DC

(Operational voltage range 85 - 150 V, ripple 10 %p-p max.)

[5] OPTIONS (multiple selections)

Standards & Approvals (must be specified)

/N: Without CE

/CE: CE marking

Other Options

blank: none

/Q: Option other than the above (specify the specification)

SPECIFICATIONS OF OPTION: Q (multiple selections)

COATING (For the detail, refer to M-System's web site.)

/C01: Silicone coating

/C02: Polyurethane coating

/C03: Rubber coating

TERMINAL SCREW MATERIAL

/S01: Stainless steel

GENERAL SPECIFICATIONS

Construction: Plug-in

Connection: M3 screw terminals (torque 0.8 N·m)

Screw terminal: Chromated steel (standard) or stainless steel

Housing material: Flame-resistant resin (black)

Isolation: Input to output to power

Overrange output: Approx. -10 to +120 % at 1 - 5 V

Zero adjustment: -5 to +5 % (front)

Span adjustment: 95 to 105 % (front)

DIP switch setting: Selecting output options

- Output Function (normal output, or loop test output of 0%, 50% and 100%.)

- Output Limit (ON, OFF)

Hold control: Contact logic selectable by the DIP switch setting

Status indicator LED 1: Green LED; indicates the transmitter's function mode (Refer to the instruction manual.)

Status indicator LED 2: Orange LED; indicates the transmitter's function mode (Refer to the instruction manual.)

INPUT SPECIFICATIONS

■ DC Current:

Shunt resistor attached to the input terminals (0.5 W)

Specify input resistance value for code Z.

■ DC Voltage: -300 - +300 V DC

Minimum span: 3 mV

Offset: Max. 1.5 times span

Input resistance

Span 3 - 10 mV : \geq 10 k Ω

Span 10 - 100 mV : \geq 10 k Ω

Span 0.1 - 1 V : \geq 100 k Ω

Span \geq 1 V : \geq 1 M Ω

■ Hold Control

Contact rating: 5 V @ 1 mA

Detection levels: \leq 1.25 k Ω / 1 V at ON
 \geq 20 k Ω / 4 V at OFF

OUTPUT SPECIFICATIONS

■ DC Current: 0 - 20 mA DC

Minimum span: 1 mA

Offset: Max. 1.5 times span

Load resistance: Output drive 15 V max.

■ DC Voltage: -10 - +12 V DC

Minimum span: 5 mV

Offset: Max. 1.5 times span

Load resistance: Output drive 1 mA max.; at \geq 0.5 V

INSTALLATION

Power Consumption

•AC:

Approx. 3 VA at 100 V

Approx. 4 VA at 200 V

Approx. 5 VA at 264 V

•DC: Approx. 3 W

Operating temperature: -5 to +55°C (23 to 131°F)

Operating humidity: 30 to 90 %RH (non-condensing)

Mounting: Surface or DIN rail

Weight: 150 g (0.33 lb)

PERFORMANCE in percentage of span

Accuracy: \pm 0.1 %

Temp. coefficient: \pm 0.015 %/°C (\pm 0.008 %/°F)

Response time: \leq 0.5 sec. (0 - 90 %)

Line voltage effect: \pm 0.1 % over voltage range

Insulation resistance: \geq 100 M Ω with 500 V DC

Dielectric strength: 2000 V AC @1 minute (input to output to power to ground)

STANDARDS & APPROVALS

CE conformity:

EMC Directive (2004/108/EC)

EMI EN 61000-6-4: 2007/A1: 2011

EMS EN 61000-6-2: 2005

Low Voltage Directive (2006/95/EC)



EN 61010-1: 2010
 Installation Category II
 Pollution Degree 2
 Input or output to power: Reinforced insulation (300 V)
 Input to output: Basic insulation (300 V)

EXTERNAL VIEW

FRONT VIEW

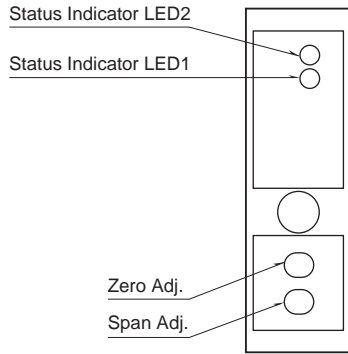

SIDE VIEW

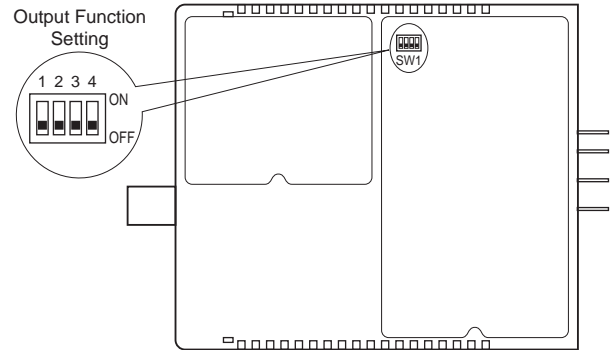

Refer to the instruction manual for detailed procedures.

DIMENSIONS unit: mm (inch)

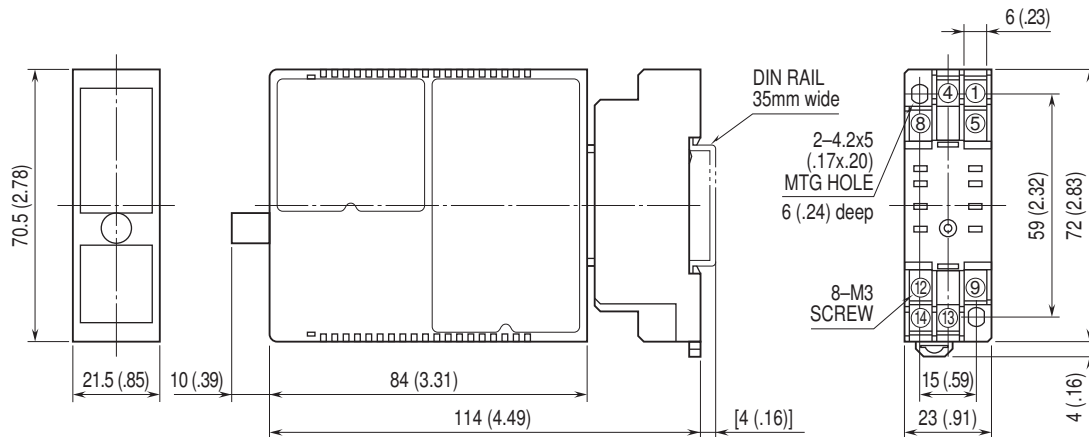

• When mounting, no extra space is needed between units.



TERMINAL ASSIGNMENTS unit: mm (inch)

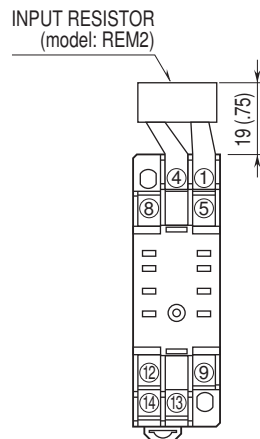

Input shunt resistor attached for current input.

SCHEMATIC CIRCUITRY & CONNECTION DIAGRAM

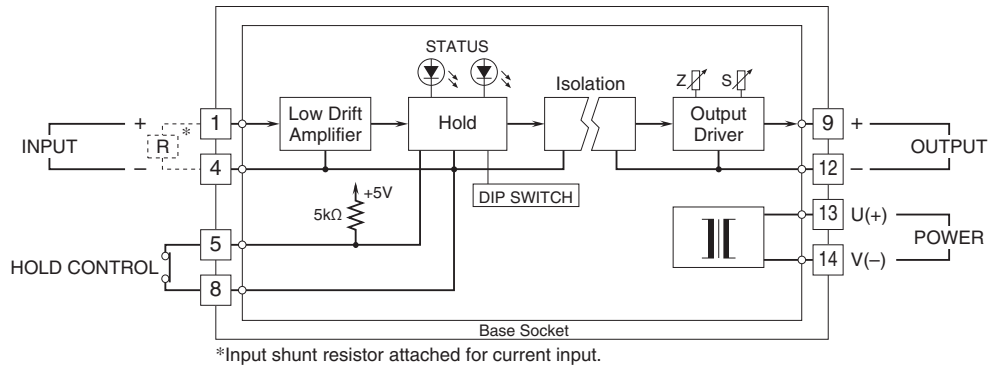

HOLD MODES

■ PEAK HOLD MODE

The transmitter output responds only to an increasing signal, holding the maximum value until a higher signal or a command to reset is received.

■ VALLEY HOLD MODE

The transmitter output responds only to a decreasing signal, holding the minimum value until a lower signal or a command to reset is received.

■ PEAK-TO-PEAK HOLD MODE

The transmitter output responds only when the input signal goes over the previously monitored maximum value or goes below the previously monitored minimum value.

The output is proportional to the peak-to-peak value, absolute difference between the maximum and the minimum values.

• Peak-to-Peak Hold Mode

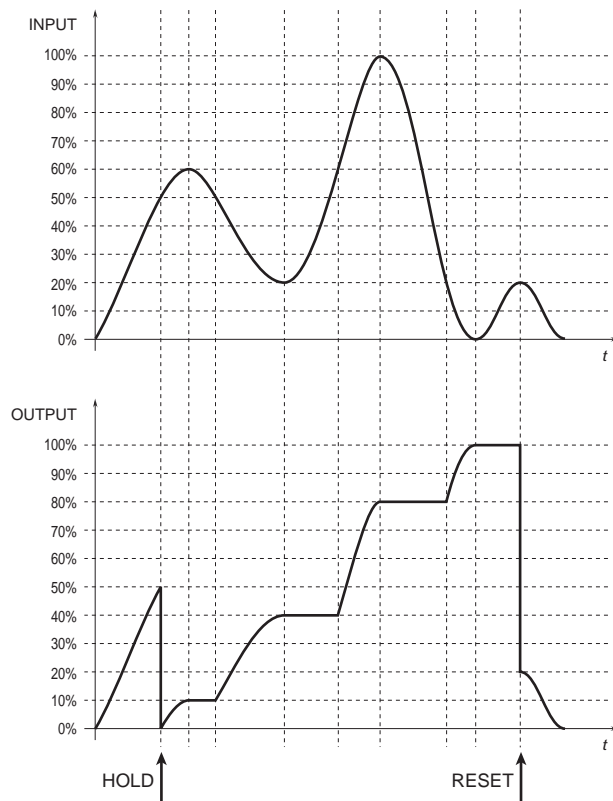

Specifications are subject to change without notice.



幸託有限公司
XIN TOP CORPORATION

TEL : (02)2598-1199
FAX : (02)2596-2331

E-mail : info@xintop.com
Website : www.xintop.com