

Super-mini Signal Conditioners Mini-M Series

LIMITER

Functions & Features

- Prevents DC output signals from going above or below preset values
- High and low limits independently adjustable from -10.0 % to +105 %
- Easy high/low limit setting with the front digital display
- CE marking
- UL approval

Typical Applications

- Protecting the receiving instrument which could malfunction with an overscale input
- Securing the minimum fuel flow in a combustion control loop

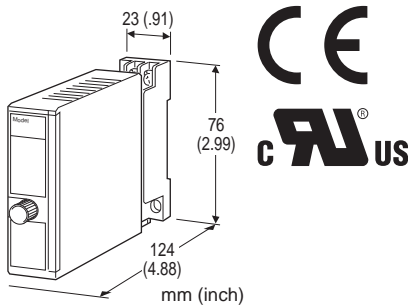

MODEL: M2LMS-[1][2]-[3][4]

ORDERING INFORMATION

- Code number: M2LMS-[1][2]-[3][4]
- Specify a code from below for each [1] through [4]. (e.g. M2LMS-6A-M2/CE/Q)
- Special input and output ranges (For codes Z & 0)
- Specify the specification for option code /Q (e.g. /C01/S01)

[1] INPUT

Current

- A: 4 - 20 mA DC (Input resistance 250 Ω)
- A1: 4 - 20 mA DC (Input resistance 50 Ω)
- B: 2 - 10 mA DC (Input resistance 500 Ω)
- C: 1 - 5 mA DC (Input resistance 1000 Ω)
- D: 0 - 20 mA DC (Input resistance 50 Ω)
- E: 0 - 16 mA DC (Input resistance 62.5 Ω)
- F: 0 - 10 mA DC (Input resistance 100 Ω)
- G: 0 - 1 mA DC (Input resistance 1000 Ω)
- H: 10 - 50 mA DC (Input resistance 100 Ω)
- J: 0 - 10 μ A DC (Input resistance 1000 Ω)

- K: 0 - 100 μ A DC (Input resistance 1000 Ω)
- GW: -1 - +1 mA DC (Input resistance 1000 Ω)
- FW: -10 - +10 mA DC (Input resistance 100 Ω)
- Z: Specify current (See INPUT SPECIFICATIONS)

Voltage

- 1: 0 - 10 mV DC (Input resistance 10 k Ω min.)
- 15: 0 - 50 mV DC (Input resistance 10 k Ω min.)
- 16: 0 - 60 mV DC (Input resistance 10 k Ω min.)
- 2: 0 - 100 mV DC (Input resistance 100 k Ω min.)
- 3: 0 - 1 V DC (Input resistance 1 M Ω min.)
- 4: 0 - 10 V DC (Input resistance 1 M Ω min.)
- 5: 0 - 5 V DC (Input resistance 1 M Ω min.)
- 6: 1 - 5 V DC (Input resistance 1 M Ω min.)
- 4W: -10 - +10 V DC (Input resistance 1 M Ω min.)
- 5W: -5 - +5 V DC (Input resistance 1 M Ω min.)
- 0: Specify voltage (See INPUT SPECIFICATIONS)

[2] OUTPUT

Current

- A: 4 - 20 mA DC (Load resistance 750 Ω max.)
- B: 2 - 10 mA DC (Load resistance 1500 Ω max.)
- C: 1 - 5 mA DC (Load resistance 3000 Ω max.)
- D: 0 - 20 mA DC (Load resistance 750 Ω max.)
- E: 0 - 16 mA DC (Load resistance 900 Ω max.)
- F: 0 - 10 mA DC (Load resistance 1500 Ω max.)
- G: 0 - 1 mA DC (Load resistance 15 k Ω max.)
- Z: Specify current (See OUTPUT SPECIFICATIONS)

Voltage

- 1: 0 - 10 mV DC (Load resistance 10 k Ω min.)
- 2: 0 - 100 mV DC (Load resistance 100 k Ω min.)
- 3: 0 - 1 V DC (Load resistance 1000 Ω min.)
- 4: 0 - 10 V DC (Load resistance 10 k Ω min.)
- 5: 0 - 5 V DC (Load resistance 5000 Ω min.)
- 6: 1 - 5 V DC (Load resistance 5000 Ω min.)
- 4W: -10 - +10 V DC (Load resistance 10 k Ω min.)
- 5W: -5 - +5 V DC (Load resistance 5000 Ω min.)
- 0: Specify voltage (See OUTPUT SPECIFICATIONS)

[3] POWER INPUT

AC Power

- M2: 100 - 240 V AC (Operational voltage range 85 - 264 V, 47 - 66 Hz)
- (90 - 264 V for UL)

DC Power

- R: 24 V DC (Operational voltage range 24 V \pm 10 %, ripple 10 %p-p max.)
- R2: 11 - 27 V DC (Operational voltage range 11 - 27 V, ripple 10 %p-p max.) (Select 'N' for 'Standards & Approvals' code.)
- P: 110 V DC (Operational voltage range 85 - 150 V, ripple 10 %p-p max.)



(110 V \pm 10 % for UL)

[4] OPTIONS (multiple selections)

STANDARDS & APPROVALS (must be specified)

/N: Without CE or UL

/CE: CE marking

/UL: UL approval (CE marking)

OTHER OPTIONS

blank: none

/Q: Option other than the above (specify the specification)
(UL not available)

SPECIFICATIONS OF OPTION: Q (multiple selections)

COATING (For the detail, refer to M-System's web site.)

/C01: Silicone coating

/C02: Polyurethane coating

/C03: Rubber coating

TERMINAL SCREW MATERIAL

/S01: Stainless steel

GENERAL SPECIFICATIONS

Construction: Plug-in

Connection: M3 screw terminals (torque 0.8 N·m)

Housing material: Flame-resistant resin (black)

Isolation: Input to output to power

Overrange output: Approx. -10 to +105 % at 1 - 5 V

Zero adjustment: -5 to +5 % (front)

Span adjustment: 95 to 105 % (front)

Limit adjustments: High and low independently adjustable from -10.0 - +105 %; 0.1 % increments (1 % increments over 100 %)

High/low selector: Double-throw SW (front)

UP/DOWN control: Double-throw, momentary SW (front)

■ INDICATORS

High/low digital display: Red LED; 6.4 mm (.25") 7 segment, 3 digits

Polarity indicator: Dual color (red/green) LED; Red with a positive set value; Green with a negative set value.

Power saving mode: Indicators turn off if the switches are untouched for 1 minute.

INPUT SPECIFICATIONS

• DC Current:

Shunt resistor attached to the input terminals (0.5 W)

Specify input resistance value for code Z.

• DC Voltage: -30 - +30 V DC

Minimum span: 3 mV

Offset: Max. 1.5 times span

Input resistance

Span 3 - 10 mV : \geq 10 k Ω

Span 10 - 100 mV : \geq 10 k Ω

Span 0.1 - 1 V : \geq 100 k Ω

Span \geq 1 V : \geq 1 M Ω

OUTPUT SPECIFICATIONS

• **DC Current:** 0 - 20 mA DC

Minimum span: 1 mA

Offset: Max. 1.5 times span

Load resistance: Output drive 15 V max.

• **DC Voltage:** -10 - +12 V DC

Minimum span: 5 mV

Offset: Max. 1.5 times span

Load resistance: Output drive 1 mA max.; at \geq 0.5 V

INSTALLATION

Power Consumption

• AC Power input:

Approx. 3 VA at 100 V

Approx. 4 VA at 200 V

Approx. 5 VA at 264 V

• **DC Power input:** Approx. 3 W

Operating temperature: -5 to +55°C (23 to 131°F)

Operating humidity: 30 to 90 %RH (non-condensing)

Mounting: Surface or DIN rail

Weight: 150 g (0.33 lbs)

PERFORMANCE in percentage of span

Accuracy: \pm 0.2 %

Setting accuracy: \pm 0.2 %

Temp. coefficient: \pm 0.015 %/°C (\pm 0.008 %/°F)

Response time: \leq 0.5 sec. (0 - 90 %)

Line voltage effect: \pm 0.1 % over voltage range

Insulation resistance: \geq 100 M Ω with 500 V DC

Dielectric strength: 2000 V AC @1 minute (input to output to power to ground)

STANDARDS & APPROVALS

CE conformity:

EMC Directive (2004/108/EC)

EN 61000-6-4 (EMI)

EN 61000-6-2 (EMS)

Low Voltage Directive (2006/95/EC)

EN 61010-1

Installation Category II

Pollution Degree 2

Max. operating voltage 300 V

Input or output to power: Reinforced insulation

Input to output: Basic insulation

Approval:

UL/C-UL nonincendive Class I, Division 2,



Groups A, B, C, and D hazardous locations
 (ANSI/ISA-12.12.01, CAN/CSA-C22.2 No.213)
 UL/C-UL general safety requirements
 (UL 61010B-1, CAN/CSA-C22.2 No.1010-1)

FRONT VIEW

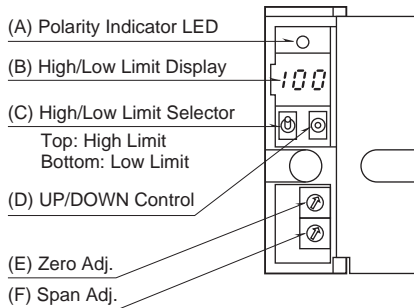

The front cover cannot be turned open by 180 deg. when there is no extra space between units.

• How to Set High Limit

Turn the High/Low Limit Selector (C) to the top.
 The High/Low Limit Display (B) shows the current high limit (-10.0 - +105 %). Press UP/DOWN Control (D) until the display shows a desired set value.
 The Polarity Indicator LED (A) is red when the set value is in positive range, green when in negative range.
 The high limit is factory set to 100 %.

• How to Set Low Limit

Turn the High/Low Limit Selector (C) to the bottom.
 The High/Low Limit Display (B) shows the current low limit (-10.0 - +105 %). Press UP/DOWN Control (D) until the display shows a desired set value.
 The Polarity Indicator LED (A) is red when the set value is in positive range, green when in negative range.
 The low limit is factory set to 0 %.

DIMENSIONS unit: mm (inch)

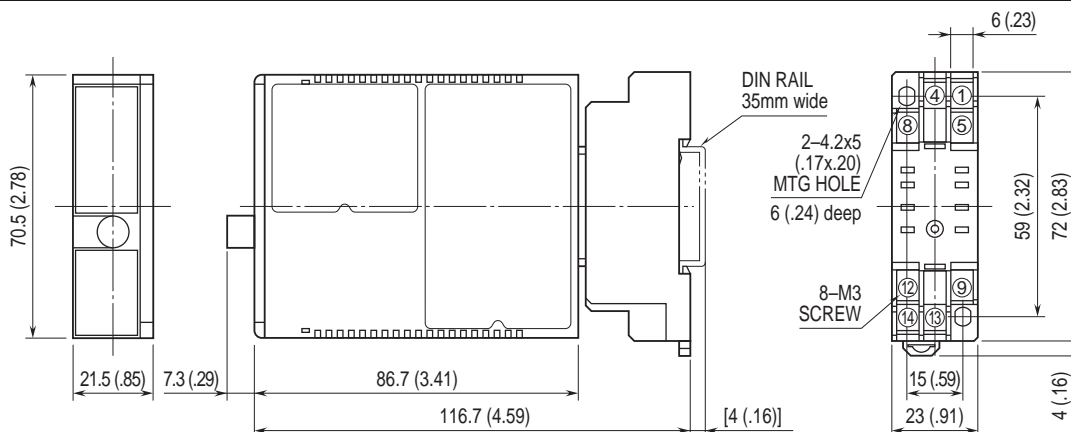

• When mounting, no extra space is needed between units.



TERMINAL ASSIGNMENTS unit: mm (inch)

INPUT RESISTOR
(model: REM2)

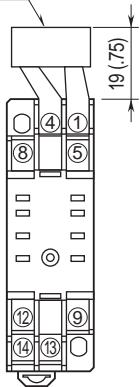

Input shunt resistor attached for current input.

SCHEMATIC CIRCUITRY & CONNECTION DIAGRAM

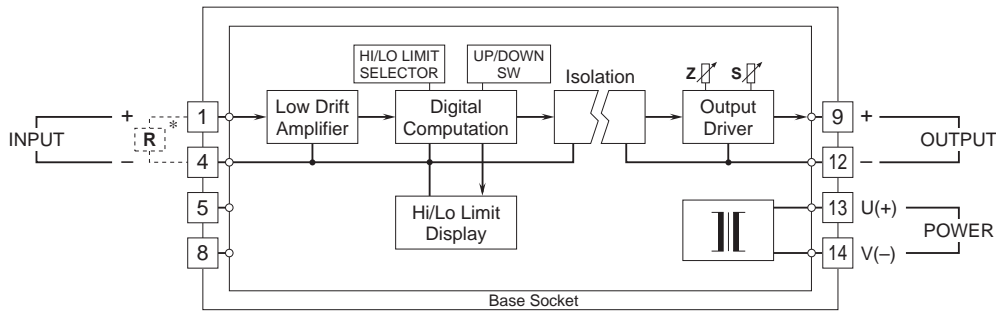

*Input shunt resistor attached for current input.



Specifications are subject to change without notice.