

## Super-mini Signal Conditioners Mini-M Series

### CT TRANSMITTER

(RMS sensing)

#### Functions & Features

- Converts alternating current from a current transformer into a standard process signal
- Minimum ripple
- Rerouted input signal does not pass through the base socket in order to protect it from melting caused by rush current of a motor
- CT Protector provided for open-circuit protection
- CE marking
- UL approval

#### Typical Applications

- Centralized monitoring and control of motors, pumps or heaters by DCS
- Monitoring power line and power supply current

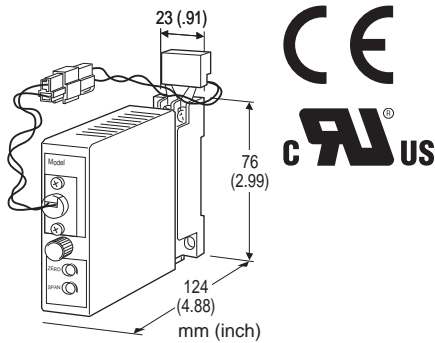

### MODEL: M2CE-[1][2]-[3][4]

#### ORDERING INFORMATION

- Code number: M2CE-[1][2]-[3][4]
- Specify a code from below for [1] through [4].  
(e.g. M2CE-5A-M2/CE/Q)
- Special output range (For codes Z & 0)
- Specify the specification for option code /Q  
(e.g. /C01/S01)

#### [1] INPUT

##### Current

- 1: 0 - 1 A AC
- 5: 0 - 5 A AC

#### [2] OUTPUT

##### Current

- A: 4 - 20 mA DC (Load resistance 750 Ω max.)
- B: 2 - 10 mA DC (Load resistance 1500 Ω max.)
- C: 1 - 5 mA DC (Load resistance 3000 Ω max.)

- D: 0 - 20 mA DC (Load resistance 750 Ω max.)
- E: 0 - 16 mA DC (Load resistance 900 Ω max.)
- F: 0 - 10 mA DC (Load resistance 1500 Ω max.)
- G: 0 - 1 mA DC (Load resistance 15 kΩ max.)
- Z: Specify current (See OUTPUT SPECIFICATIONS)

##### Voltage

- 1: 0 - 10 mV DC (Load resistance 10 kΩ min.)
- 2: 0 - 100 mV DC (Load resistance 100 kΩ min.)
- 3: 0 - 1 V DC (Load resistance 1000 Ω min.)
- 4: 0 - 10 V DC (Load resistance 10 kΩ min.)
- 5: 0 - 5 V DC (Load resistance 5000 Ω min.)
- 6: 1 - 5 V DC (Load resistance 5000 Ω min.)
- 4W: -10 - +10 V DC (Load resistance 10 kΩ min.)
- 0: Specify voltage (See OUTPUT SPECIFICATIONS)

#### [3] POWER INPUT

##### AC Power

- M: 85 - 264 V AC (Operational voltage range 85 - 264 V, 47 - 66 Hz)  
(Select '/N' for 'Standards & Approvals' code.)
- M2: 100 - 240 V AC (Operational voltage range 85 - 264 V, 47 - 66 Hz)  
(90 - 264 V for UL)

##### DC Power

- R: 24 V DC  
(Operational voltage range 24 V ±10 %, ripple 10 %p-p max.)
- R2: 11 - 27 V DC  
(Operational voltage range 11 - 27 V, ripple 10 %p-p max.)  
(Select '/N' for 'Standards & Approvals' code.)
- P: 110 V DC  
(Operational voltage range 85 - 150 V, ripple 10 %p-p max.)  
(110 V ±10 % for UL)

#### [4] OPTIONS (multiple selections)

##### STANDARDS & APPROVALS (must be specified)

- /N: Without CE or UL
- /CE: CE marking
- /UL: UL approval (CE marking)

##### OTHER OPTIONS

- blank: none
- /Q: Option other than the above (specify the specification)  
(UL not available)

#### SPECIFICATIONS OF OPTION: Q (multiple selections)

##### COATING (For the detail, refer to M-System's web site.)

- /C01: Silicone coating
- /C02: Polyurethane coating
- /C03: Rubber coating

##### TERMINAL SCREW MATERIAL

- /S01: Stainless steel



## GENERAL SPECIFICATIONS

**Construction:** Plug-in  
**Connection:** M3 screw terminals (torque 0.8 N·m)  
**Housing material:** Flame-resistant resin (black)  
**Isolation:** Input to output to power  
**Input waveform**  
**RMS sensing:** Up to 15 % of 3rd harmonic content  
**Overrange output:** 0 to 120 % at 1 - 5 V  
**Zero adjustment:** -5 to +5 % (front)  
**Span adjustment:** 95 to 105 % (front)

## INPUT SPECIFICATIONS

**Frequency:** 50 or 60 Hz  
**Input burden:**  
≤ 0.1 VA (input 0 - 1 A)  
≤ 0.5 VA (input 0 - 5 A)  
**Overload capacity:** 500 % of rating for 5 sec., 120 % continuous  
**Operational range:** 0 - 120 % of rating

## OUTPUT SPECIFICATIONS

• **DC Current:** 0 - 20 mA DC  
**Minimum span:** 1 mA  
**Offset:** Max. 1.5 times span  
**Load resistance:** Output drive 15 V max.  
• **DC Voltage:** 0 - 12 V DC  
**Minimum span:** 5 mV  
**Offset:** Max. 1.5 times span  
**Load resistance:** Output drive 1 mA max.; at ≥ 0.5 V

## INSTALLATION

**Power Consumption**  
• **AC Power input:**  
Approx. 3 VA at 100 V  
Approx. 4 VA at 200 V  
Approx. 5 VA at 264 V  
• **DC Power input:** Approx. 3 W  
**Operating temperature:** -5 to +55°C (23 to 131°F)  
**Operating humidity:** 30 to 90 %RH (non-condensing)  
**Mounting:** Surface or DIN rail  
**Weight:** 150 g (0.33 lbs)

## PERFORMANCE in percentage of span

**Accuracy:** ±0.3 %  
**Temp. coefficient:** ±0.015 %/°C (±0.008 %/°F)  
**Response time:** ≤ 0.5 sec. (0 - 90 %)  
**Ripple:** 0.5 %p-p max. (100/120 Hz)  
**Line voltage effect:** ±0.1 % over voltage range  
**Insulation resistance:** ≥ 100 MΩ with 500 V DC  
**Dielectric strength:** 2000 V AC @1 minute (input to output

to power to ground)

## STANDARDS & APPROVALS

**CE conformity:**  
EMC Directive (2004/108/EC)  
EN 61000-6-4 (EMI)  
EN 61000-6-2 (EMS)  
Low Voltage Directive (2006/95/EC)  
EN 61010-1  
Installation Category II  
Pollution Degree 2  
Max. operating voltage 300 V  
Input or output to power: Reinforced insulation  
Input to output: Basic insulation

**Approval:**  
UL/C-UL nonincendive Class I, Division 2,  
Groups A, B, C, and D hazardous locations  
(UL 1604, CAN/CSA-C22.2 No.213)  
UL/C-UL general safety requirements  
(UL 61010B-1, CAN/CSA-C22.2 No.1010-1)



## EXTERNAL DIMENSIONS & TERMINAL ASSIGNMENTS unit: mm (inch)

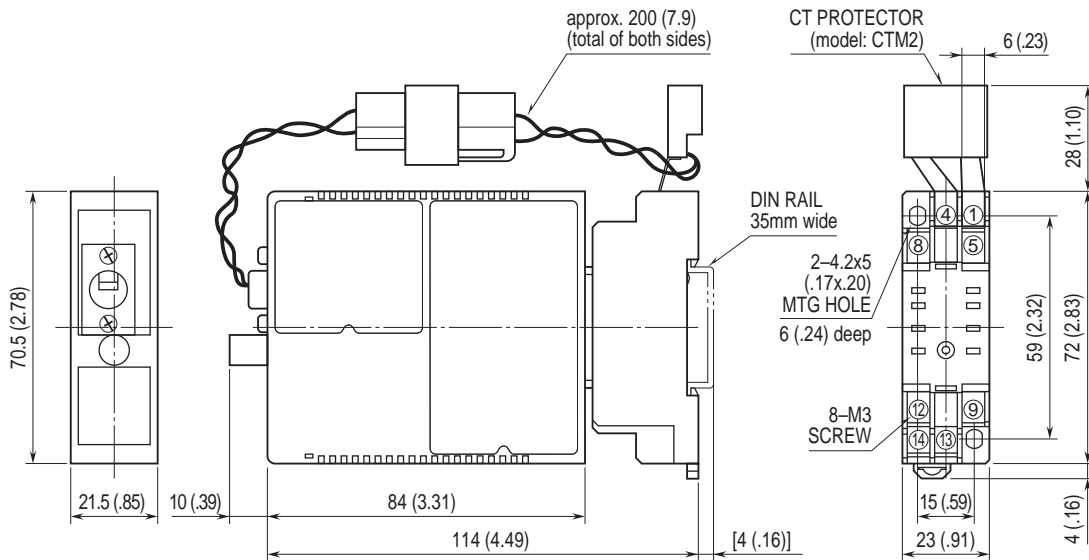

## SCHEMATIC CIRCUITRY & CONNECTION DIAGRAM

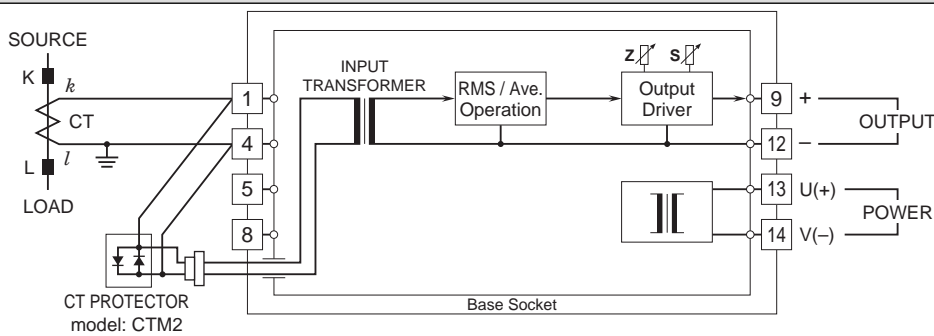

Specifications are subject to change without notice.