

Super-mini Signal Conditioners Mini-M Series

COMMUNICATION CONTROLLER

(DeviceNet™ use)

Functions & Features

- Receiving up to 16 Mini-M modules
- Enabling interfacing analog I/Os to DeviceNet™
- Power supplied through printed wiring on the base
- UL approval, CE marking

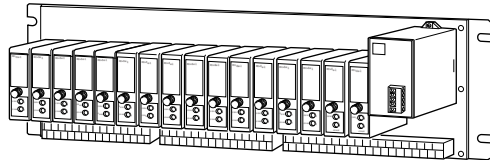

DeviceNet™
CONFORMANCE TESTED

MODEL: M2BD-[1][2]-[3][4]

ORDERING INFORMATION

- Code number: M2BD-[1][2]-[3][4]

Specify a code from below for each [1] through [4].

(e.g. M2BD-161-R/UL)

Power input specification for each I/O modules must be the same as that of the base.

[1] CAPACITY

04: 4 positions

08: 8 positions

16: 16 positions

[2] I/O TYPE

1: Input

2: Output

[3] POWER INPUT

AC Power

K: 85 - 132 V AC (Operational voltage range 85 - 132 V, 47 - 66 Hz)
(CE or UL not available)

DC Power

R: 24 V DC

(Operational voltage range 24 V ±10 %, ripple 10 %p-p max.)

[4] OPTIONS

STANDARDS & APPROVALS

blank: Without UL or CE

/UL: UL approval (CE marking)

GENERAL SPECIFICATIONS

Capacity: 4, 8 or 16 positions

Connection

Transmission: Terminal block

Field I/O: M3 screw terminals (torque 0.8 N·m)

Power input: M3 screw terminals (torque 0.8 N·m)

Transmission cable: approved for DeviceNet

Screw terminal: Nickel-plated steel

Isolation: Field I/O to transmission to power

Node address setting: DIP switch; 00 - 63

Baud rate setting: DIP switch

125 kbps (factory default), 250 kbps, 500 kbps

Power indicator: Green LED turns on with power supplied.

MS (Module Status) indicator: bi-color (green/red)

LED indicates device status.

NS (Network Status) indicator: bi-color (green/red)

LED indicates status of the communication link.

INPUT SPECIFICATIONS

Input modules: Mini-M series; output 1 - 5 V DC;
(non-isolated types are not usable.)

■ ANALOG INPUT

Input range: See each I/O module spec.

Voltage at the field I/O terminals limited within 30 V DC for UL.

Isolation: transformer (by Mini-M module)

A/D conversion output: 16-bit binary

Signal range 0 - 100 % is converted into hexadecimal 0000 - 1770 (0 - 6000). -15 to 0 % is represented by 2's complements.

Overall range is represented by hexadecimal FC7C - 1AF4 (-900 - +6900), for -15 - +115 %.

OUTPUT SPECIFICATIONS

Output modules: Model M2VS; input 1 - 5 V DC

■ ANALOG OUTPUT

Output range: See model M2VS spec.

Isolation: Transformer

D/A conversion output: 16-bit binary

Signal range 0 - 100 % is converted into hexadecimal 0000 - 1770 (0 - 6000). -15 to 0 % is represented by 2's complements.

Overall range is represented by hexadecimal FC7C - 1AF4 (-900 - +6900), for -15 - +115 %.



INSTALLATION

• **AC Power input:**

Power Consumption:

approx. 6 VA without I/O module

approx. 30 VA with 4 modules (M2DY)

approx. 50 VA with 8 modules

approx. 90 VA with 16 modules

• **DC Power input**

Current consumption:

approx. 0.25 A without I/O module

approx. 1 A with 4 modules (M2DY)

approx. 1.5 A with 8 modules

approx. 2.5 A with 16 modules

Power output: 11 - 25 V DC; 60 mA max. at 24 V

(supplied from the comm. terminal)

Operating temperature: -5 to +55°C (23 to 131°F)

Operating humidity: 30 to 90 %RH (non-condensing)

Atmosphere: No corrosive gas or heavy dust

Mounting: Surface

Weight: Without I/O module

M2BD-04 1.2 kg (2.6 lbs)

M2BD-08 1.5 kg (3.3 lbs)

M2BD-16 2 kg (4.4 lbs)

PERFORMANCE in percentage of span

A/D conversion: Accuracy of input module $\pm 0.1\%$

D/A conversion: Accuracy of M2VS $\pm 0.1\%$

Power loss time: ≤ 10 msec.

Insulation resistance: ≥ 100 M Ω with 500V DC

Dielectric strength: 1000 V AC @1 minute (power to I/O module to communication module)

STANDARDS & APPROVALS

CE conformity:

EMC Directive (2004/108/EC)

EMI EN 61000-6-4

EMS EN 61000-6-2

Low Voltage Directive (2006/95/EC)

EN 61010-1

Measurement Category II

Pollution Degree 2

Max. operating voltage 300V

Input or output to power: Reinforced insulation

Input to output: Basic insulation

Approval:

UL/C-UL nonincendive Class I, Division 2,

Groups A, B, C, and D hazardous locations

(UL 1604, CAN/CSA-C22.2 No.213);

UL/C-UL general safety requirements

(UL 3111-1, CAN/CSA-C22.2 No.1010-1)



COMM. MODULE FRONT PANEL

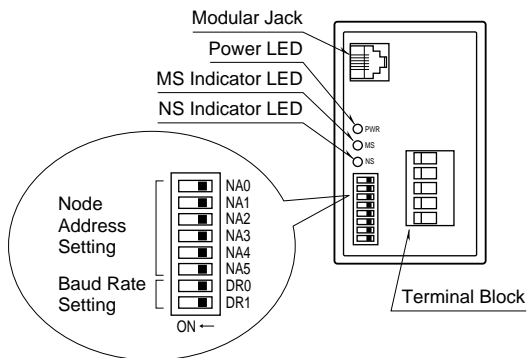

Refer to the instruction manual for detailed precedures.



DIMENSIONS unit: mm (inch)

■ **M2BD-041 (INPUT BASE)**

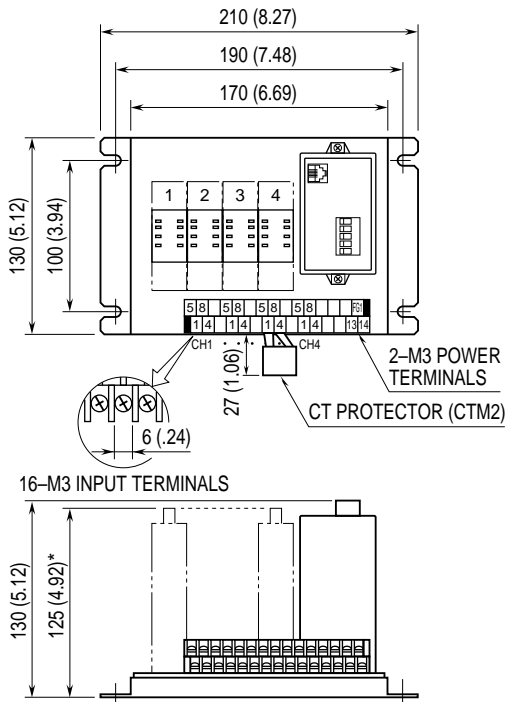

*165 (6.50) required for pneumatic tubing for M2PV.

■ **M2BD-042 (OUTPUT BASE)**

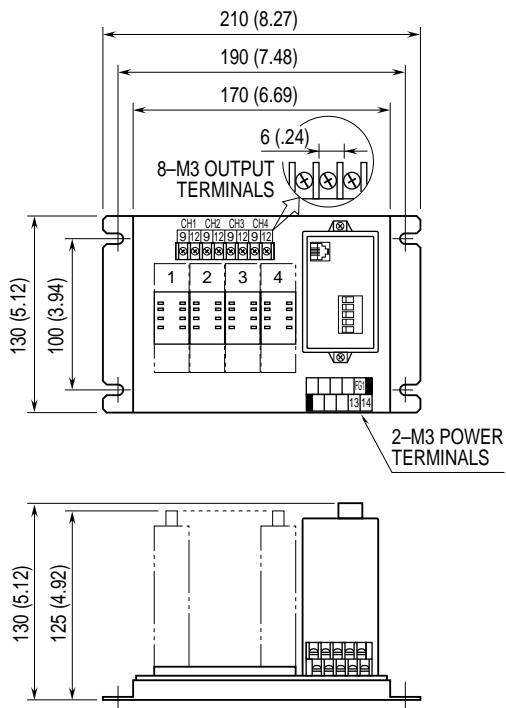

■ M2BD-081 (INPUT BASE)

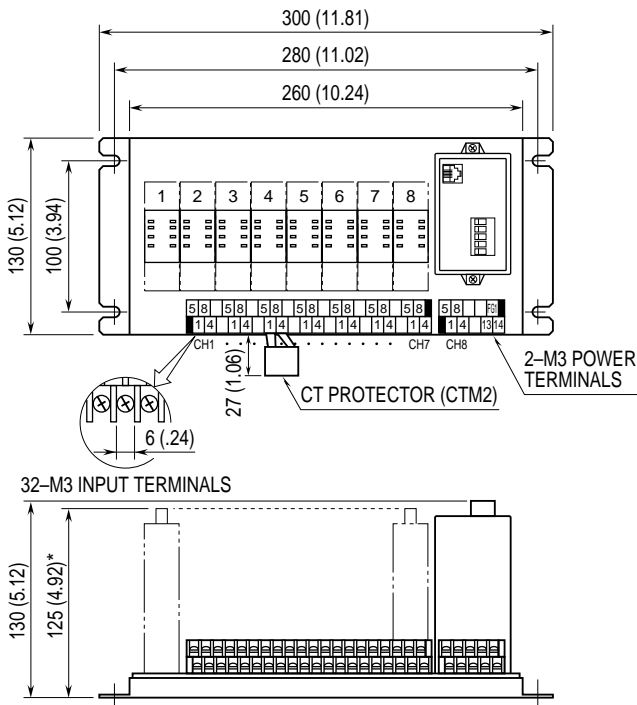

*165 (6.50) required for pneumatic tubing for M2PV.

■ M2BD-082 (OUTPUT BASE)

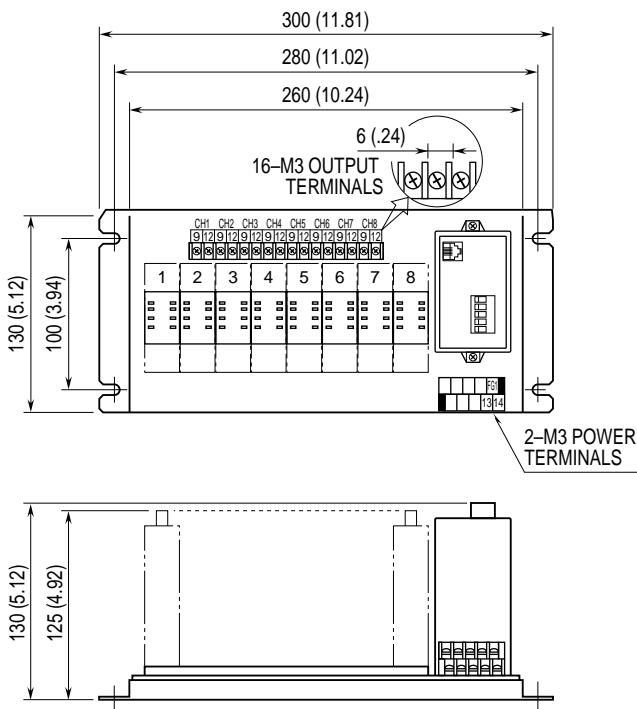

■ M2BD-161 (INPUT BASE)

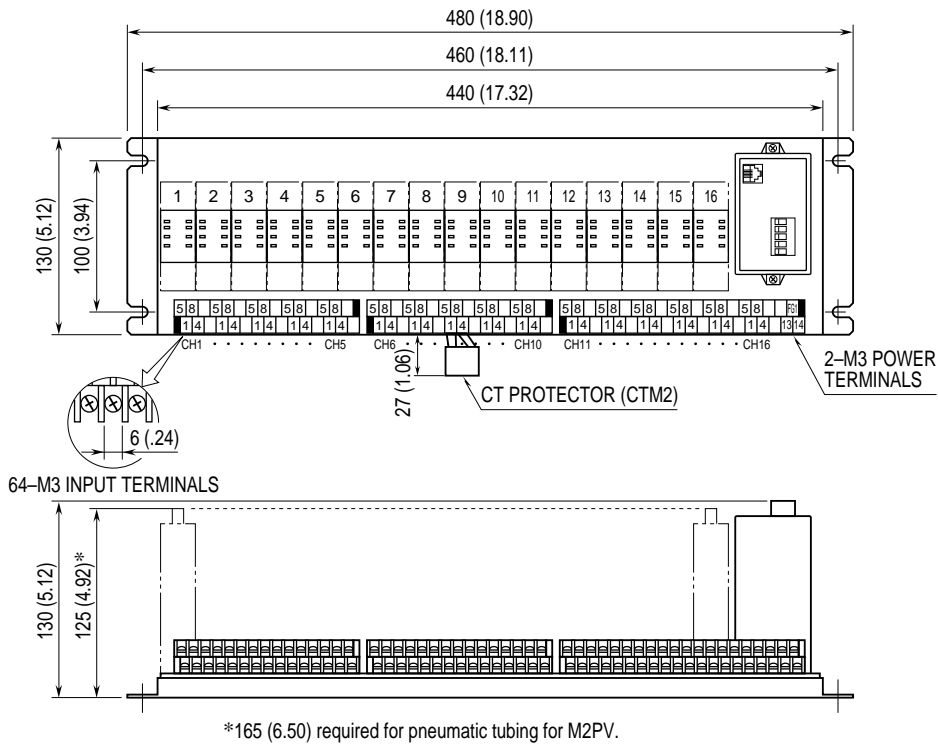

■ M2BD-162 (OUTPUT BASE)

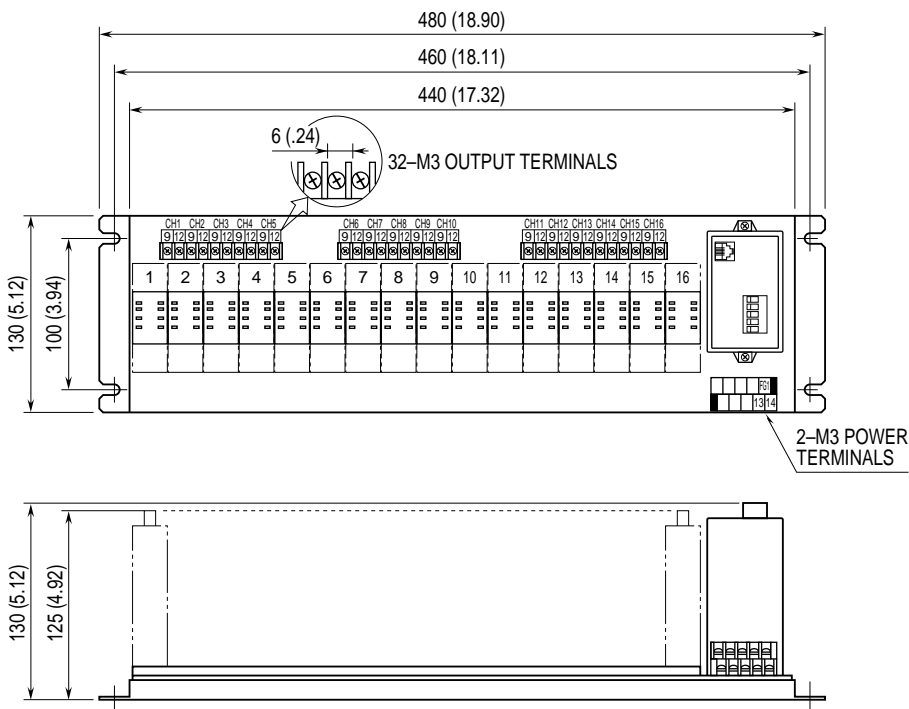

MOUNTING REQUIREMENTS unit: mm (inch)

■ M2BD-04

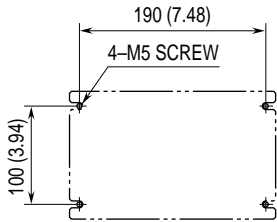

■ M2BD-08

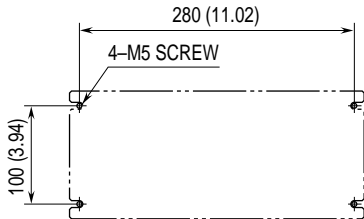

■ M2BD16

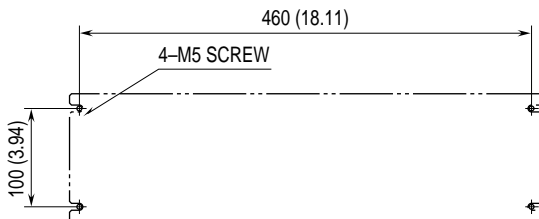

SCHEMATIC CIRCUITRY & CONNECTION DIAGRAM

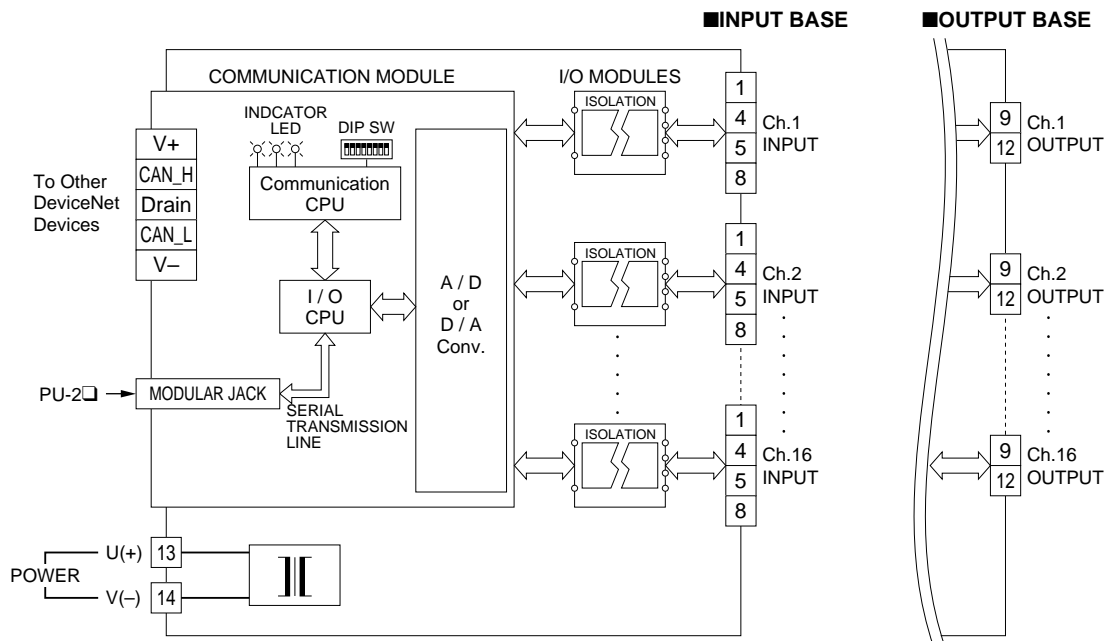

Specifications are subject to change without notice.

