

## Dual Output Plug-in Signal Conditioners W-UNIT

### POTENTIOMETER TRANSMITTER

#### Functions & Features

- Providing two DC outputs proportional to a potentiometer or slidewire position input
- Constant voltage excitation allows use with pots with total resistances from 100  $\Omega$  - 10 k $\Omega$  without affecting accuracy
- 50 % zero/span adjustments with minimal interaction
- Isolation up to 2000 V AC
- Fast response type available
- LCD meter
- High-density mounting

#### Typical Applications

- Tank levels
- Positions

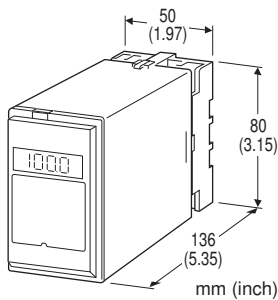

## MODEL: WMS-[1][2]-[3][4]

### ORDERING INFORMATION

- Code number: WMS-[1][2]-[3][4]
- Specify a code from below for each [1] through [4].  
(e.g. WMS-A6-B/E/Q)
- Special output range (For codes Z & 0)
  - Specify the specification for option code /Q  
(e.g. /C01/S01)
- Note: When the user requires a current and a voltage output, specify the current to be the Output 1 which allows a greater load.

### INPUT POTENTIOMETER

Total resistance 100  $\Omega$  - 10 k $\Omega$

#### [1] OUTPUT 1

##### Current

- A: 4 - 20 mA DC (Load resistance 600  $\Omega$  max.)
- B: 2 - 10 mA DC (Load resistance 1200  $\Omega$  max.)
- C: 1 - 5 mA DC (Load resistance 2400  $\Omega$  max.)

- D: 0 - 20 mA DC (Load resistance 600  $\Omega$  max.)
- E: 0 - 16 mA DC (Load resistance 750  $\Omega$  max.)
- F: 0 - 10 mA DC (Load resistance 1200  $\Omega$  max.)
- G: 0 - 1 mA DC (Load resistance 12 k $\Omega$  max.)
- Z: Specify current (See OUTPUT SPECIFICATIONS)

##### Voltage

- 1: 0 - 10 mV DC (Load resistance 10 k $\Omega$  min.)
- 2: 0 - 100 mV DC (Load resistance 100 k $\Omega$  min.)
- 3: 0 - 1 V DC (Load resistance 1000  $\Omega$  min.)
- 4: 0 - 10 V DC (Load resistance 10 k $\Omega$  min.)
- 5: 0 - 5 V DC (Load resistance 5000  $\Omega$  min.)
- 6: 1 - 5 V DC (Load resistance 5000  $\Omega$  min.)
- 4W: -10 - +10 V DC (Load resistance 10 k $\Omega$  min.)
- 5W: -5 - +5 V DC (Load resistance 5000  $\Omega$  min.)
- 0: Specify voltage (See OUTPUT SPECIFICATIONS)

#### [2] OUTPUT 2

##### Current

- A: 4 - 20 mA DC (Load resistance 350  $\Omega$  max.)
- B: 2 - 10 mA DC (Load resistance 700  $\Omega$  max.)
- C: 1 - 5 mA DC (Load resistance 1400  $\Omega$  max.)
- D: 0 - 20 mA DC (Load resistance 350  $\Omega$  max.)
- E: 0 - 16 mA DC (Load resistance 430  $\Omega$  max.)
- F: 0 - 10 mA DC (Load resistance 700  $\Omega$  max.)
- G: 0 - 1 mA DC (Load resistance 7000  $\Omega$  max.)
- Z: Specify current (See OUTPUT SPECIFICATIONS)

##### Voltage

Same range availability as Output 1

#### [3] POWER INPUT

##### AC Power

- B: 100 V AC
- C: 110 V AC
- D: 115 V AC
- F: 120 V AC
- G: 200 V AC
- H: 220 V AC
- J: 240 V AC

##### DC Power

- S: 12 V DC
- R: 24 V DC
- V: 48 V DC
- P: 110 V DC

#### [4] OPTIONS (multiple selections)

##### Input Signal Indicator

- blank: Without
- /E: With (0.0 - 100.0 % display)

##### Response Time (0 - 90 %)

- blank: Standard ( $\leq$  0.5 sec.)
- /K: Fast Response (Approx. 25 msec.)



## Other Options

blank: none

/Q: Option other than the above (specify the specification)

## SPECIFICATIONS OF OPTION: Q (multiple selections)

### COATING (For the detail, refer to M-System's web site.)

/C01: Silicone coating

/C02: Polyurethane coating

/C03: Rubber coating

### TERMINAL SCREW MATERIAL

/S01: Stainless steel

## GENERAL SPECIFICATIONS

Construction: Plug-in

Connection: M3.5 screw terminals

Screw terminal: Chromated steel (standard) or stainless steel

Housing material: Flame-resistant resin (black)

Isolation: Input to output 1 to output 2 to power

Zero adjustment: 0 - 50 % of total resistance (front)

Span adjustment: 50 - 100 % of total resistance (front)

LCD meter: Indicating scaled input; 0.1 % increments

## INPUT SPECIFICATIONS

Minimum span: 50 % of total resistance

Excitation: 0.5 V DC

## OUTPUT SPECIFICATIONS

■ DC Current: 0 - 20 mA DC

Minimum span: 1 mA

Offset: Max. 1.5 times span

Load resistance: Output drive 12 V max. for Output 1;  
7 V max. for Output 2

■ DC Voltage: -10 - +12 V DC

Minimum span: 5 mV

Offset: Max. 1.5 times span

Load resistance: Output drive 1 mA max. at  $\geq 0.5$  V

## INSTALLATION

### Power input

•AC: Operational voltage range: rating  $\pm 10$  %, 50/60  $\pm 2$  Hz, approx. 3 VA

•DC: Operational voltage range: rating  $\pm 10$  %, or 85 - 150 V for 110 V rating, ripple 10 %p-p max., approx. 3 W (125 mA at 24 V)

Operating temperature: -5 to +55°C (23 to 131°F)

Operating humidity: 30 to 90 %RH (non-condensing)

Mounting: Surface or DIN rail

Weight: 400 g (0.88 lb)

## PERFORMANCE in percentage of span

Accuracy:  $\pm 0.1$  %

Display accuracy:  $\pm(0.1$  % of FS + 1 digit)

Temp. coefficient:  $\pm 0.015$  %/°C ( $\pm 0.008$  %/°F)

Line voltage effect:  $\pm 0.1$  % over voltage range

Insulation resistance:  $\geq 100$  M $\Omega$  with 500 V DC

Dielectric strength: 2000 V AC @1 minute

(input to output to power to ground)

1000 V AC @ 1 minute (output 1 to output 2)



## DIMENSIONS unit: mm (inch)

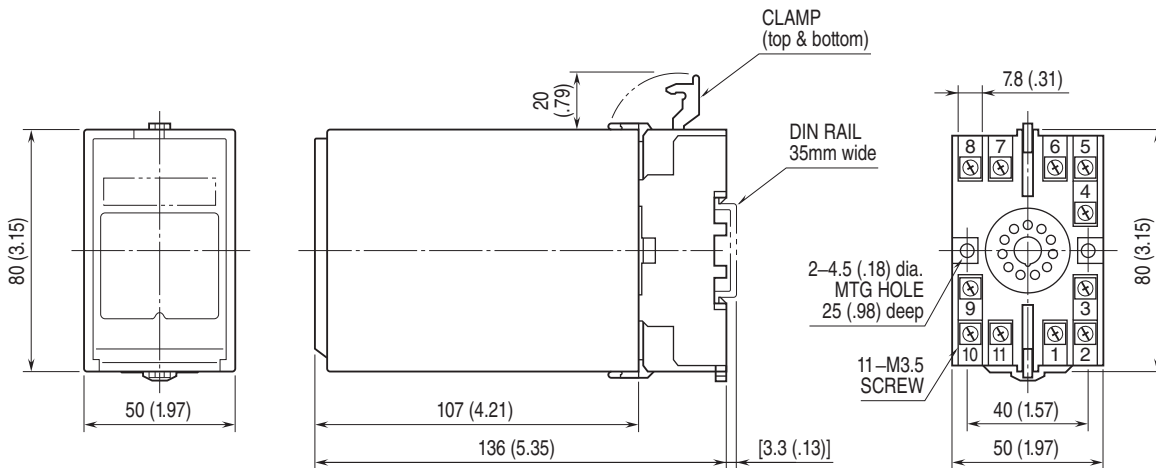

• When mounting, no extra space is needed between units.

## SCHEMATIC CIRCUITRY & CONNECTION DIAGRAM

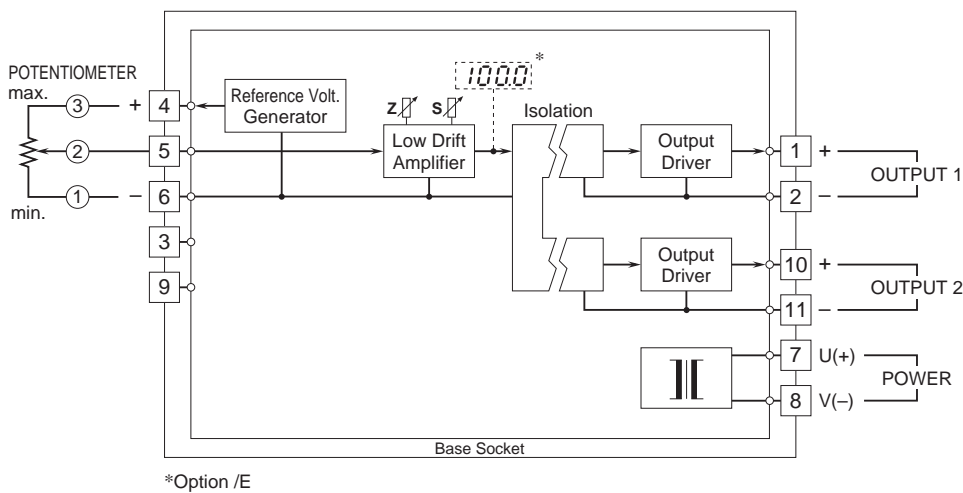

Specifications are subject to change without notice.