

Dual Output Plug-in Signal Conditioners W-UNIT

LINEARIZER

(field-programmable)

Functions & Features

- Accepting non-linear input and providing linearized output, proportional to the process variables
- Micro-processor based
- On-site calibration up to 16 points using a hand-held programmer PU-2x
- Field-programmable input range
- Isolation up to 2000 V AC
- High-density mounting

Typical Applications

- V-notch weir
- Gas analyzer
- Irregular-shaped tank level input for volume calculation
- Square root extracting for DP transmitter

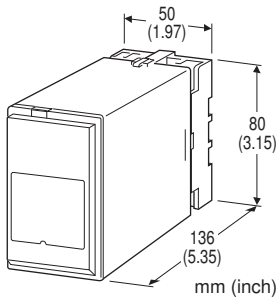

MODEL: WJFX-[1][2][3]-[4][5]

ORDERING INFORMATION

- Code number: WJFX-[1][2][3]-[4][5]
- Specify a code from below for each [1] through [5].
(e.g. WJFX-6A6-B/Q)
- Linearization data (max. 16 points)
 - Special input and output ranges (For codes U1, U2, U3, Z & 0)
- Default setting will be used if not otherwise specified.
Use Ordering Information Sheet (No. ESU-1669) to specify linearization data when the I/O signals are nonlinear. Linear data will be programmed if not otherwise specified.
- Specify the specification for option code /Q (e.g. /C01/S01)
- When the user requires a current and a voltage output, specify the current to be the Output 1 which allows a greater load.

[1] INPUT

Current

- A: 4 - 20 mA DC (Input resistance 250 Ω)
- H: 10 - 50 mA DC (Input resistance 100 Ω)

Voltage

- 6: 1 - 5 V DC (Input resistance 1 MΩ min.)
- U1: Range ±100 mV; minimum span 3 mV
- U2: Range ±1000 mV; minimum span 30 mV
- U3: Range ±10 V; minimum span 0.3 V

[2] OUTPUT 1

Current

- A: 4 - 20 mA DC (Load resistance 600 Ω max.)
- B: 2 - 10 mA DC (Load resistance 1200 Ω max.)
- C: 1 - 5 mA DC (Load resistance 2400 Ω max.)
- D: 0 - 20 mA DC (Load resistance 600 Ω max.)
- E: 0 - 16 mA DC (Load resistance 750 Ω max.)
- F: 0 - 10 mA DC (Load resistance 1200 Ω max.)
- G: 0 - 1 mA DC (Load resistance 12 kΩ max.)
- Z: Specify current (See OUTPUT SPECIFICATIONS)

Voltage

- 1: 0 - 10 mV DC (Load resistance 10 kΩ min.)
- 2: 0 - 100 mV DC (Load resistance 100 kΩ min.)
- 3: 0 - 1 V DC (Load resistance 1000 Ω min.)
- 4: 0 - 10 V DC (Load resistance 10 kΩ min.)
- 5: 0 - 5 V DC (Load resistance 5000 Ω min.)
- 6: 1 - 5 V DC (Load resistance 5000 Ω min.)
- 4W: -10 - +10 V DC (Load resistance 10 kΩ min.)
- 5W: -5 - +5 V DC (Load resistance 5000 Ω min.)
- 0: Specify voltage (See OUTPUT SPECIFICATIONS)

[3] OUTPUT 2

Current

- A: 4 - 20 mA DC (Load resistance 350 Ω max.)
- B: 2 - 10 mA DC (Load resistance 700 Ω max.)
- C: 1 - 5 mA DC (Load resistance 1400 Ω max.)
- D: 0 - 20 mA DC (Load resistance 350 Ω max.)
- E: 0 - 16 mA DC (Load resistance 430 Ω max.)
- F: 0 - 10 mA DC (Load resistance 700 Ω max.)
- G: 0 - 1 mA DC (Load resistance 7000 Ω max.)
- Z: Specify current (See OUTPUT SPECIFICATIONS)

Voltage

Same range availability as Output 1

[4] POWER INPUT

AC Power

- B: 100 V AC
- C: 110 V AC
- D: 115 V AC
- F: 120 V AC
- G: 200 V AC



H: 220 V AC

J: 240 V AC

DC Power

S: 12 V DC

R: 24 V DC

V: 48 V DC

[5] OPTIONS

blank: none

/Q: With options (specify the specification)

SPECIFICATIONS OF OPTION: Q (multiple selections)

COATING (For the detail, refer to M-System's web site.)

/C01: Silicone coating

/C02: Polyurethane coating

/C03: Rubber coating

TERMINAL SCREW MATERIAL

/S01: Stainless steel

RELATED PRODUCTS

- JX configurator connection kit (model: JXCON)
- Programming Unit (model: PU-2x)

GENERAL SPECIFICATIONS

Construction: Plug-in

Connection: M3.5 screw terminals

Screw terminal: Chromated steel (standard) or stainless steel

Housing material: Flame-resistant resin (black)

Isolation: Input to output 1 to output 2 to power

Zero adjustment: -5 to +5 % (front)

Span adjustment: 95 to 105 % (front)

Linearization: 16 points max. within the range of -15.00 - +115.00 % input or output; represented as percentage of full-scale

Adjustments: Programming Unit (model: PU-2x)

(Refer to the users manual of JXCON for the adjustments configurable with JXCON.)

- Linearization data
- Input range
- Zero and span
- Simulating output
- Others

Input range can be changed with Codes U1, U2 or U3 and limited within ranges of each code type.

INPUT SPECIFICATIONS

■ **DC Current:**

Shunt resistor attached to the input terminals (0.5 W)

■ **DC Voltage:** -10 - +10 V DC

Minimum span: 3 mV

Offset: Max. 3 times span

Input resistance (Input Range: Input Resistance)

U1: ±100 mV: 20 kΩ min.

U2: ±1000 mV: 20 kΩ min.

U3: ±10 V: 1 MΩ min.

Default setting will be used if not otherwise specified.

U1: 0 - 100 mV DC

U2: 0 - 1 V DC

U3: 0 - 10 V DC

OUTPUT SPECIFICATIONS

■ **DC Current:** 0 - 20 mA DC

Minimum span: 1 mA

Offset: Max. 1.5 times span

Load resistance: Output drive 12 V max. for Output 1; 7 V max. for Output 2

■ **DC Voltage:** -10 - +10 V DC

Minimum span: 5 mV

Offset: Max. 1.5 times span

Load resistance: Output drive 1 mA max.; at ≥ 0.5 V

INSTALLATION

Power input

• **AC:** Operational voltage range: rating ±10 %, 50/60 ±2 Hz, approx. 3.5 VA

• **DC:** Operational voltage range: rating ±10 %, approx. 3 W (110 mA at 24 V) (ripple 10 %p-p max.)

Operating temperature: -5 to +55°C (23 to 131°F)

Operating humidity: 30 to 90 %RH (non-condensing)

Mounting: Surface or DIN rail

Weight: 400 g (0.88 lb)

PERFORMANCE in percentage of span

Accuracy: ±0.1 % with segment gain ≤ 1 [±0.1 % × gain] with segment gain ≥ 1

Temp. coefficient: ±0.015 %/°C (±0.008 %/°F)

Response time: ≤ 0.5 sec. (0 - 90 %)

Line voltage effect: ±0.1 % over voltage range

Insulation resistance: ≥ 100 MΩ with 500 V DC

Dielectric strength: 2000 V AC @1 minute

(input to output to power to ground)

1000 V AC @ 1 minute (output 1 to output 2)



DIMENSIONS unit: mm (inch)

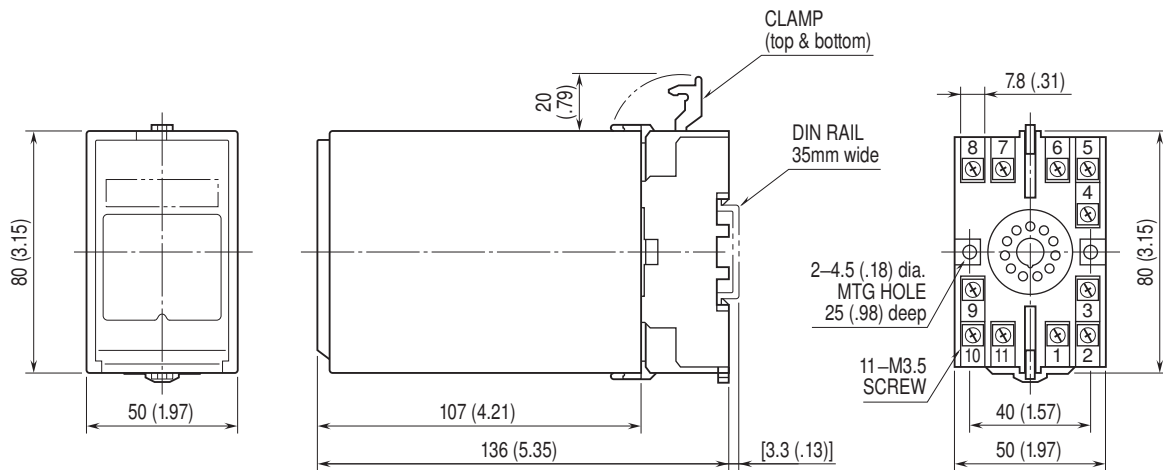

• When mounting, no extra space is needed between units.

TERMINAL ASSIGNMENTS unit: mm (inch)

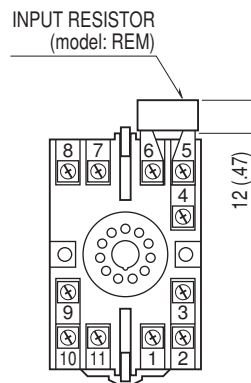

Input shunt resistor attached for current input.

SCHEMATIC CIRCUITRY & CONNECTION DIAGRAM

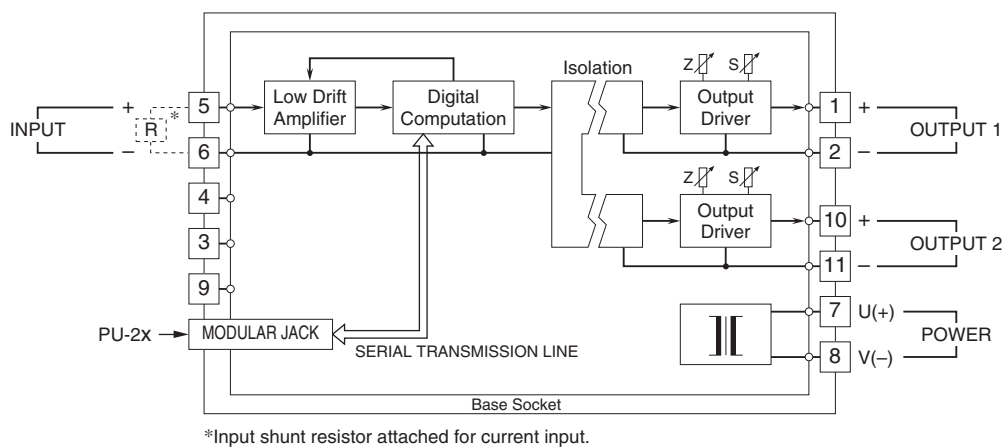

Specifications are subject to change without notice.

