

## Space-saving Dual Output Signal Conditioners Mini-MW Series

### CURRENT LOOP SUPPLY

(with square root extractor)

#### Functions & Features

- Powers a 4 - 20 mA DC current loop
- Square root extraction
- Shortcircuit protection
- Applicable to smart transmitters

#### Typical Applications

- Various 2-wire transmitters

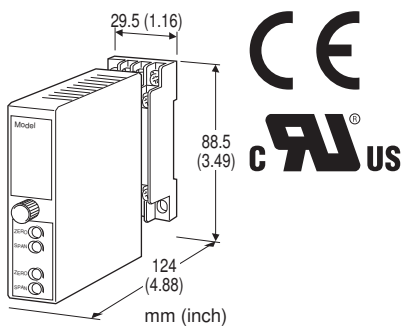

### MODEL: W2DNY-24[1][2]-[3][4]

### ORDERING INFORMATION

- Code number: W2DNY-24[1][2]-[3][4]
  - Specify a code from below for each [1] through [4].  
(e.g. W2DNY-24A6-M2/CE/Q)
  - Special output ranges (For codes Z & 0)
  - Specify the specification for option code 'Q.'  
(e.g. /C01/S01)
- Note: If one of the outputs should be a current range, specify it for the Output 1 to allow a greater load.

### SUPPLY OUTPUT

24: 24 V DC

### INPUT

#### Current

4 - 20 mA DC

### [1] OUTPUT 1

#### Current

- A: 4 - 20 mA DC (Load resistance 750  $\Omega$  max.)
- B: 2 - 10 mA DC (Load resistance 1500  $\Omega$  max.)
- C: 1 - 5 mA DC (Load resistance 3000  $\Omega$  max.)
- D: 0 - 20 mA DC (Load resistance 750  $\Omega$  max.)

- E: 0 - 16 mA DC (Load resistance 900  $\Omega$  max.)
- F: 0 - 10 mA DC (Load resistance 1500  $\Omega$  max.)
- G: 0 - 1 mA DC (Load resistance 15 k $\Omega$  max.)
- Z: Specify current (See OUTPUT SPECIFICATIONS)

#### Voltage

- 1: 0 - 10 mV DC (Load resistance 10 k $\Omega$  min.)
- 2: 0 - 100 mV DC (Load resistance 100 k $\Omega$  min.)
- 3: 0 - 1 V DC (Load resistance 1000  $\Omega$  min.)
- 4: 0 - 10 V DC (Load resistance 10 k $\Omega$  min.)
- 5: 0 - 5 V DC (Load resistance 5000  $\Omega$  min.)
- 6: 1 - 5 V DC (Load resistance 5000  $\Omega$  min.)
- 0: Specify voltage (See OUTPUT SPECIFICATIONS)

### [2] OUTPUT 2

Y: None

#### Current

- A: 4 - 20 mA DC (Load resistance 350  $\Omega$  max.)
- B: 2 - 10 mA DC (Load resistance 700  $\Omega$  max.)
- C: 1 - 5 mA DC (Load resistance 1400  $\Omega$  max.)
- D: 0 - 20 mA DC (Load resistance 350  $\Omega$  max.)
- E: 0 - 16 mA DC (Load resistance 430  $\Omega$  max.)
- F: 0 - 10 mA DC (Load resistance 700  $\Omega$  max.)
- G: 0 - 1 mA DC (Load resistance 7000  $\Omega$  max.)
- Z: Specify current (See OUTPUT SPECIFICATIONS)

#### Voltage

Same range availability as Output 1

### [3] POWER INPUT

#### AC Power

M: 85 - 264 V AC (Operational voltage range 85 - 264 V, 47 - 66 Hz)

(Select 'N' for 'Standards & Approvals' code.)

M2: 100 - 240 V AC (Operational voltage range 85 - 264 V, 47 - 66 Hz)

(90 - 264 V for UL)

#### DC Power

R: 24 V DC

(Operational voltage range 24 V  $\pm$ 10 %, ripple 10 %p-p max.)

R2: 11 - 27 V DC

(Operational voltage range 11 - 27 V, ripple 10 %p-p max.)

(Select 'N' for 'Standards & Approvals' code.)

P: 110 V DC

(Operational voltage range 85 - 150 V, ripple 10 %p-p max.)

(110 V  $\pm$ 10 % for UL)

### [4] OPTIONS (multiple selections)

#### Standards & Approvals (must be specified)

/N: Without CE or UL

/CE: CE marking

/UL: UL approval, CE marking

#### Other Options



blank: none

/Q: Option other than the above (specify the specification)  
(UL not available)

## SPECIFICATIONS OF OPTION: Q (multiple selections)

**COATING (For the detail, refer to M-System's web site.)**

/C01: Silicone coating

/C02: Polyurethane coating

/C03: Rubber coating

**TERMINAL SCREW MATERIAL**

/S01: Stainless steel

## GENERAL SPECIFICATIONS

**Construction:** Plug-in

**Connection:** M3 screw terminals (torque 0.8 N·m)

**Screw terminal:** Chromated steel (standard) or stainless steel

**Housing material:** Flame-resistant resin (black)

**Isolation:** Input to output 1 to output 2 to power

**Overrange output:** 0 to 110 % at 1 - 5 V

**Zero adjustment:** -5 to +5 % (front)

**Span adjustment:** 95 to 105 % (front)

**Low-end cutout:** Approx. 4 - 8 % (output)

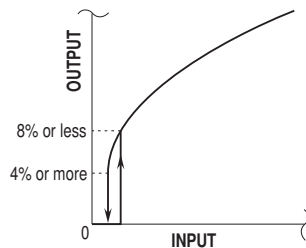

## SUPPLY OUTPUT

(across the terminals 1 - 5)

**Output voltage:** 24 - 28 V DC with no load

18 V DC min. at 20 mA

**Current rating:** ≤ 22 mA DC

• **Shortcircuit Protection**

**Current limited:** 30 mA max.

**Protected time duration:** No limit

## INPUT SPECIFICATIONS

■ **DC Current:** Input resistors incorporated

Approx. 300 Ω (50 Ω as receiving resistor, 250 Ω across the monitor terminals)

## OUTPUT SPECIFICATIONS

■ **DC Current:** 0 - 20 mA DC

**Minimum span:** 1 mA

**Offset:** Max. 1.5 times span

**Load resistance:** Output drive 15 V max. for Output 1;  
7 V max. for Output 2

■ **DC Voltage:** 0 - 12 V DC (up to 10 V for Output 2)

**Minimum span:** 10 mV

**Offset:** Max. 1.5 times span

**Load resistance:** Output drive 1 mA max.; at ≥0.5 V

## INSTALLATION

**Power Consumption**

• **AC:**

Approx. 5 VA at 100 V

Approx. 6 VA at 200 V

Approx. 7 VA at 264 V

• **DC:** Approx. 3 W

**Operating temperature:** -5 to +55°C (23 to 131°F)

**Operating humidity:** 30 to 90 %RH (non-condensing)

**Mounting:** Surface or DIN rail

**Weight:** 200 g (0.44 lb)

## PERFORMANCE in percentage of span

**Accuracy:** ±0.2 % (input 1 - 100 %)

**Temp. coefficient:** ±0.015 %/°C (±0.008 %/°F)

**Response time:** ≤ 0.5 sec. (0 - 90 %)

**Line voltage effect**

**Supply output:** ±3 % over voltage range

**Output signal:** ±0.1 % over voltage range

**Insulation resistance:** ≥ 100 MΩ with 500 V DC

**Dielectric strength:** 2000 V AC @1 minute (input to output 1 to output 2 to power to ground)

## STANDARDS & APPROVALS

**CE conformity:**

EMC Directive (2004/108/EC)

EMI EN 61000-6-4: 2007

EMS EN 61000-6-2: 2005

Low Voltage Directive (2006/95/EC)

EN 61010-1: 2001

Installation Category II

Pollution Degree 2

Input or output 1 or output 2 to power input:

Reinforced insulation (300 V)

Input to output 1 to output 2: Basic insulation (300 V)

**Approval:**

UL/C-UL nonincendive Class I, Division 2,

Groups A, B, C, and D

(ANSI/ISA-12.12.01:2007, CAN/CSA-C22.2 No.213:1987)

UL/C-UL general safety requirements

(UL 61010B-1:2003, CAN/CSA-C22.2 No.1010-1:1992)



## DIMENSIONS unit: mm (inch)

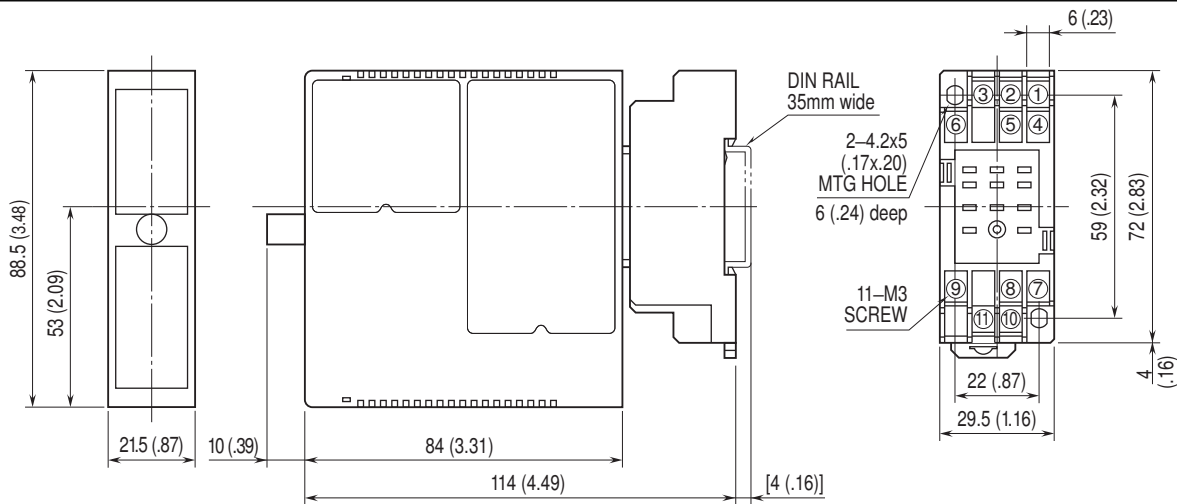

When mounting, no extra space is needed between units.

## SCHEMATIC CIRCUITRY & CONNECTION DIAGRAM

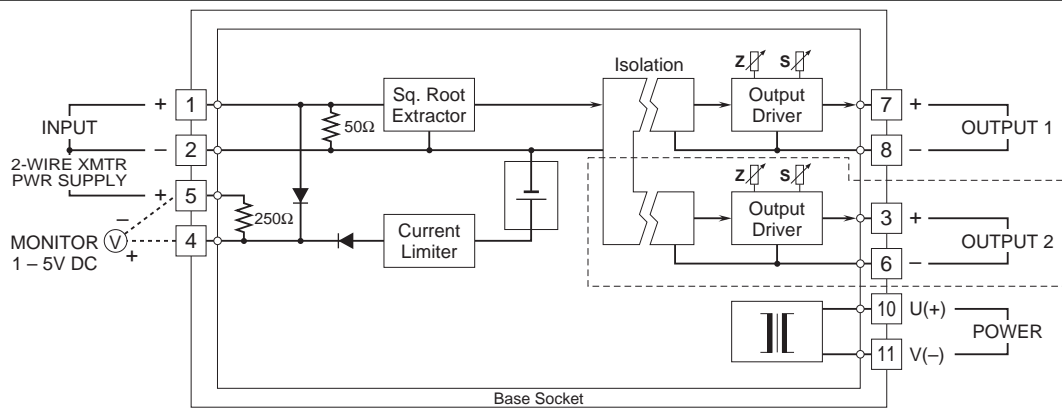

Remark: The section enclosed by broken line is only with 2nd output option.

### ■ When Used as DC Supply

2-WIRE TRANSMITTER

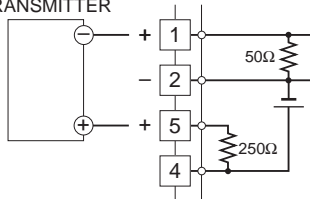

### ■ When Used as Square Root Extractor

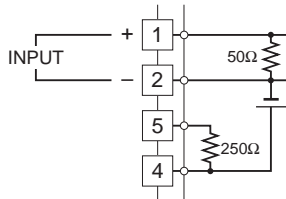

Specifications are subject to change without notice.