

Plug-in Signal Conditioners M-UNIT

TACHOGENERATOR TRANSMITTER

Functions & Features

- Converting an AC voltage from a tachogenerator (tachometer) into a standard process signal
- Wide input range
- Isolation up to 2000 V AC
- LCD meter (engineering unit display selectable)
- Simple loop test output (0 % and 100 %)
- High-density mounting

Typical Applications

- Measuring rotating or moving speed of multispeed motors, belt conveyers, metering pumps

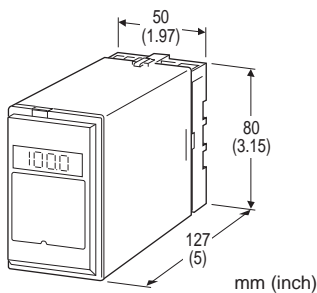

MODEL: TG-[1][2]-[3][4]

ORDERING INFORMATION

- Code number: TG-[1][2]-[3][4]
Specify a code from below for each [1] through [4].
(e.g. TG-AA-B/E2/Q)
- Special input and output ranges
(For codes U, Z & 0)
- Specify the specification for option code /Q
(e.g. /C01/S01)

[1] INPUT

Voltage

- 1: 0 - 35 V AC (Input resistance 100 kΩ min.)
- 2: 0 - 50 mV AC (Input resistance 100 kΩ min.)
- 3: 0 - 60 mV AC (Input resistance 100 kΩ min.)
- 4: 0 - 100 mV AC (Input resistance 100 kΩ min.)
- 5: 0 - 1 V AC (Input resistance 100 kΩ min.)
- 6: 0 - 10 V AC (Input resistance 100 kΩ min.)
- 61: 0 - 20 V AC (Input resistance 100 kΩ min.)
- 7: 0 - 100 V AC (Input resistance 100 kΩ min.)
- 8: 0 - 110 V AC (Input resistance 100 kΩ min.)
- 9: 0 - 150 V AC (Input resistance 100 kΩ min.)
- A: 0 - 200 V AC (Input resistance 100 kΩ min.)

- B: 0 - 250 V AC (Input resistance 100 kΩ min.)
- U: Specify voltage (See INPUT SPECIFICATIONS)
(0 % input must be 0 V.)

[2] OUTPUT

Current

- A: 4 - 20 mA DC (Load resistance 750 Ω max.)
- B: 2 - 10 mA DC (Load resistance 1500 Ω max.)
- C: 1 - 5 mA DC (Load resistance 3000 Ω max.)
- D: 0 - 20 mA DC (Load resistance 750 Ω max.)
- E: 0 - 16 mA DC (Load resistance 900 Ω max.)
- F: 0 - 10 mA DC (Load resistance 1500 Ω max.)
- G: 0 - 1 mA DC (Load resistance 15 kΩ max.)
- Z: Specify current (See OUTPUT SPECIFICATIONS)

Voltage

- 1: 0 - 10 mV DC (Load resistance 10 kΩ min.)
- 2: 0 - 100 mV DC (Load resistance 100 kΩ min.)
- 3: 0 - 1 V DC (Load resistance 100 Ω min.)
- 4: 0 - 10 V DC (Load resistance 1000 Ω min.)
- 5: 0 - 5 V DC (Load resistance 500 Ω min.)
- 6: 1 - 5 V DC (Load resistance 500 Ω min.)
- 4W: -10 - +10 V DC (Load resistance 2000 Ω min.)
- 5W: -5 - +5 V DC (Load resistance 1000 Ω min.)
- 0: Specify voltage (See OUTPUT SPECIFICATIONS)

[3] POWER INPUT

AC Power

- B: 100 V AC
- C: 110 V AC
- D: 115 V AC
- F: 120 V AC
- G: 200 V AC
- H: 220 V AC
- J: 240 V AC

DC Power

- S: 12 V DC
- R: 24 V DC
- V: 48 V DC
- P: 110 V DC (Not selectable with Option /E2)

[4] OPTIONS (multiple selections)

Input Signal Indicator

blank: Without

/E: With (0.0 - 100.0 % display)

/E2: With (in engineering unit with backlight and the simple loop test output)

Other Options

blank: none

/Q: Option other than the above (specify the specification)



SPECIFICATIONS OF OPTION: Q (multiple selections)

COATING (For the detail, refer to M-System's web site.)

/C01: Silicone coating

/C02: Polyurethane coating

/C03: Rubber coating

TERMINAL SCREW MATERIAL

/S01: Stainless steel

GENERAL SPECIFICATIONS

Construction: Plug-in

Connection: M3.5 screw terminals

Screw terminal: Chromated steel (standard) or stainless steel

Housing material: Flame-resistant resin (black)

Isolation: Input to output to power

Overrange output: 0 to 120 % at 1 - 5 V

Zero adjustment: -5 to +5 % (front)

Span adjustment: 95 to 105 % (front)

Display scaling: -10000 - +10000; ex-factory set to 0.00 - 100.00 (%)

Engineering unit: %, μ V, mV, V, mA, A, °C, °F, Ω , DEG K, mHz, Hz, kHz, VAC, AAC, mg, g, kg, t, rpm or rps selectable

Simple loop test output: 0 % and 100 % signal simulated by selecting the front switch positions.

INPUT SPECIFICATIONS

•AC Voltage: 0 - 250 V AC

Minimum span: 50 mV

Frequency: 15 Hz min., 1 kHz max. with 100 % input

Input resistance: \geq 100 k Ω

OUTPUT SPECIFICATIONS

■ DC Current: 0 - 20 mA DC

Minimum span: 1 mA

Offset: Max. 1.5 times span

Load resistance: Output drive 15 V max.

■ DC Voltage: -10 - +12 V DC

Minimum span: 5 mV

Offset: Max. 1.5 times span

Load resistance: Output drive 10 mA max.; 5 mA for negative voltage output; at \geq 0.5 V

INSTALLATION

Power input

•AC: Operational voltage range: rating \pm 10 %, 50/60 \pm 2 Hz, approx. 2 VA

(approx. 3 VA with Option /E2)

•DC: Operational voltage range: rating \pm 10 %, or 85 - 150 V for 110 V rating (ripple 10 % p-p max.) approx. 2 W (80 mA at 24 V; approx. 3 W with Option /E2)

Operating temperature: -5 to +60°C (23 to 140°F)

Operating humidity: 30 to 90 %RH (non-condensing)

Mounting: Surface or DIN rail

Weight: 450 g (0.99 lb)

PERFORMANCE in percentage of span

Accuracy: \pm 0.4 %

Display accuracy: \pm (0.4 % of FS + 1 digit)

Simple loop test output setting accuracy: \pm 0.5 %

Temp. coefficient: \pm 0.05 %/°C (\pm 0.03 %/°F)

Response time: \leq 0.7 sec. (0 - 90 %)

Ripple: 0.5 %p-p max.

Line voltage effect: \pm 0.1 % over voltage range

Insulation resistance: \geq 100 M Ω with 500 V DC

Dielectric strength: 2000 V AC @1 minute (input to output to power to ground)



EXTERNAL VIEW

OPTION /E

OPTION /E2

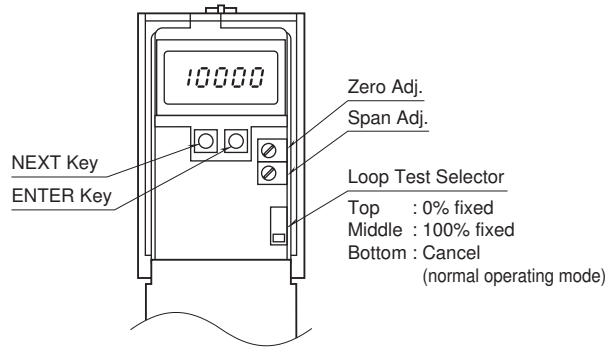
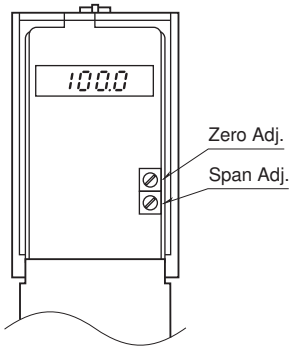

EXTERNAL DIMENSIONS & TERMINAL ASSIGNMENTS unit: mm (inch)

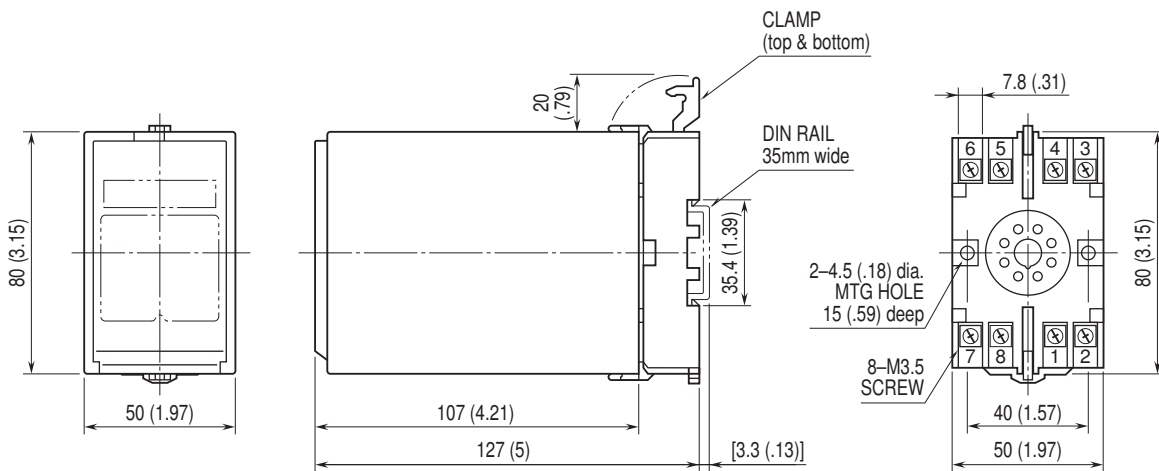

• When mounting, no extra space is needed between units.

SCHEMATIC CIRCUITRY & CONNECTION DIAGRAM

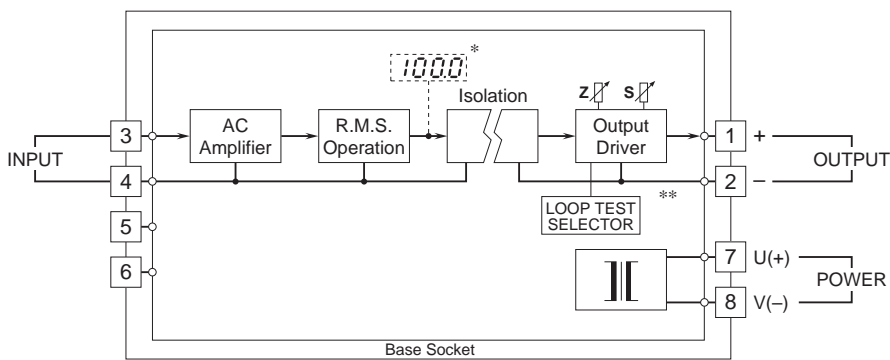

* Option /E, E2

** Option /E2



Specifications are subject to change without notice.