

Plug-in Signal Conditioners M-UNIT

THERMOCOUPLE TRANSMITTER

Functions & Features

- Accepting direct input from a thermocouple and providing a standard process signal
- 7-segment linearization
- Burnout protection
- High-accuracy cold junction compensation
- Signal isolation
- Fast response type available
- High-density mounting

Typical Applications

- High-accuracy cold junction compensation benefits narrow span measurements
- 0.1 μA burnout sensing enables long distance transmission with minimum offset drifts
- Electric furnace (isolation)
- No burnout type can connect to a single T/C in parallel with a recorder

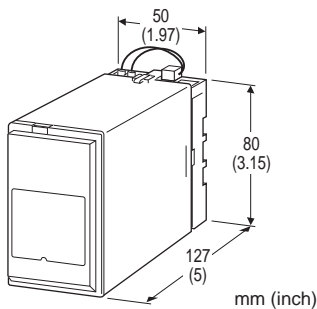

MODEL: TCS-[1][2]-[3][4]

ORDERING INFORMATION

- Code number: TCS-[1][2]-[3][4]
Specify a code from below for each [1] through [4].
(e.g. TCS-2A-B/K/BL/CE/Q)
- Temperature range (e.g. 0 - 800°C)
- Special output range (For codes Z & 0)
- Specify the specification for option code /Q
(e.g. /C01/S01)

[1] INPUT THERMOCOUPLE

- 1: (PR) (Usable Range 0 to 1760°C, 32 to 3200°F)
- 2: K (CA) (Usable range -270 to +1370°C, -454 to +2498°F)
- 3: E (CRC) (Usable range -270 to +1000°C, -454 to +1832°F)
- 4: J (IC) (Usable range -210 to +1200°C, -346 to +2192°F)
- 5: T (CC) (Usable range -270 to +400°C, -454 to +752°F)
- 6: B (RH) (Usable range 0 to 1820°C, 32 to 3308°F)

- 7: R (Usable range -50 to +1760°C, -58 to +3200°F)
- 8: S (Usable range -50 to +1760°C, -58 to +3200°F)
- N: N (Usable range -270 to +1300°C, -454 to +2372°F)
- 0: Specify

[2] OUTPUT

Current

- A: 4 - 20 mA DC (Load resistance 750 Ω max.)
- B: 2 - 10 mA DC (Load resistance 1500 Ω max.)
- C: 1 - 5 mA DC (Load resistance 3000 Ω max.)
- D: 0 - 20 mA DC (Load resistance 750 Ω max.)
- E: 0 - 16 mA DC (Load resistance 900 Ω max.)
- F: 0 - 10 mA DC (Load resistance 1500 Ω max.)
- G: 0 - 1 mA DC (Load resistance 15 kΩ max.)
- Z: Specify current (See OUTPUT SPECIFICATIONS)

Voltage

- 1: 0 - 10 mV DC (Load resistance 10 kΩ min.)
- 2: 0 - 100 mV DC (Load resistance 100 kΩ min.)
- 3: 0 - 1 V DC (Load resistance 3000 Ω min.)
- 4: 0 - 10 V DC (Load resistance 10 kΩ min.)
- 5: 0 - 5 V DC (Load resistance 5000 Ω min.)
- 6: 1 - 5 V DC (Load resistance 5000 Ω min.)
- 0: Specify voltage (See OUTPUT SPECIFICATIONS)

[3] POWER INPUT

AC Power

- B: 100 V AC
- C: 110 V AC
- D: 115 V AC
- F: 120 V AC
- G: 200 V AC
- H: 220 V AC
- J: 240 V AC

DC Power

- S: 12 V DC
- R: 24 V DC
- V: 48 V DC

[4] OPTIONS (multiple selections)

Response Time (0 - 90 %)

- blank: Standard (≤ 0.5 sec.)
- /K: Fast Response (Approx. 25 msec.)

Burnout

- blank: Upscale burnout
- /BL: Downscale burnout
- /BN: No burnout

Standards & Approvals (must be specified)

- /CE: CE marking

Other Options

- blank: none
- /Q: Option other than the above (specify the specification)



SPECIFICATIONS OF OPTION: Q (multiple selections)

COATING (For the detail, refer to M-System's web site.)

/C01: Silicone coating

/C02: Polyurethane coating

/C03: Rubber coating

TERMINAL SCREW MATERIAL

/S01: Stainless steel

GENERAL SPECIFICATIONS

Construction: Plug-in

Connection: M3.5 screw terminals

Screw terminal: Chromated steel (standard) or stainless steel

Housing material: Flame-resistant resin (black)

Isolation: Input to output to power

Overrange output: Approx. -10 to +120 % at 1 - 5 V

Zero adjustment: -5 to +5 % (front)

Span adjustment: 95 to 105 % (front)

Linearization: Standard

Cold junction compensation: CJC sensor attached to the input terminals (B thermocouple is without CJC as standard)

INPUT SPECIFICATIONS

Minimum span: 3 mV

Offset: Max. 1.5 times span

Input resistance: 30 kΩ min.

Burnout sensing: 0.1 μA

Minimum span (in °C)

(PR): min. span 370°C

K (CA): min. span 75°C

E (CRC): min. span 50°C

J (IC): min. span 60°C

T (CC): min. span 75°C

B (RH): min. span 780°C

R: min. span 360°C

S: min. span 380°C

N: min. span 110°C

Minimum span (in °F)

(PR): min. span 670°F

K (CA): min. span 140°F

E (CRC): min. span 90°F

J (IC): min. span 110°F

T (CC): min. span 140°F

B (RH): min. span 1410°F

R: min. span 650°F

S: min. span 690°F

N: min. span 200°F

Remark: The described accuracy may be partially not

satisfied when the temperature ranges below 0°C. Consult factory.

OUTPUT SPECIFICATIONS

■ **DC Current:** 0 - 20 mA DC

Minimum span: 1 mA

Offset: Max. 1.5 times span

Load resistance: Output drive 15 V max.

■ **DC Voltage:** -10 - +12 V DC

Minimum span: 5 mV

Offset: Max. 1.5 times span

Load resistance: Output drive 1 mA max. at ≥ 3 V

INSTALLATION

Power input

• **AC:** Operational voltage range: rating ±10 %, 50/60 ±2 Hz, approx. 2 VA

• **DC:** Operational voltage range: rating ±10 % ripple 10 %p-p max., approx. 2.6 W (110 mA at 24 V)

Operating temperature: -5 to +60°C (23 to 140°F)

Operating humidity: 30 to 90 %RH (non-condensing)

Mounting: Surface or DIN rail

Weight: 350 g (0.77 lbs)

PERFORMANCE in percentage of span

Accuracy: ±0.3 % (at over 400°C or 750°F for R, S and PR; over 770°C or 1420°F for B)

Cold junction compensation error

(at 20°C ±10°C or 68°F ±18°F)

K, E, J, T & N: ±0.5°C or ±0.9°F

S, R & PR: ±1°C or ±1.8°F

Temp. coefficient: ±0.015 %/°C (±0.008 %/°F)

(at over 400°C or 750°F for R, S and PR; over 770°C or 1420°F for B)

Burnout response: ≤ 10 sec.

Line voltage effect: ±0.1 % over voltage range

Insulation resistance: ≥ 100 MΩ with 500 V DC

Dielectric strength:

1350 V AC @1 minute (input to output)

2300 V AC @1 minute (input or output to power to ground)

STANDARDS & APPROVALS

CE conformity:

EMC Directive (2004/108/EC)

EMI EN 61000-6-4: 2007

EMS EN 61000-6-2: 2005

Low Voltage Directive (2006/95/EC)

EN 61010-1: 2001

Installation Category II

Pollution Degree 2



Input or output to power: Reinforced insulation (300 V)

Input to output: Basic insulation (300 V)

DIMENSIONS unit: mm (inch)

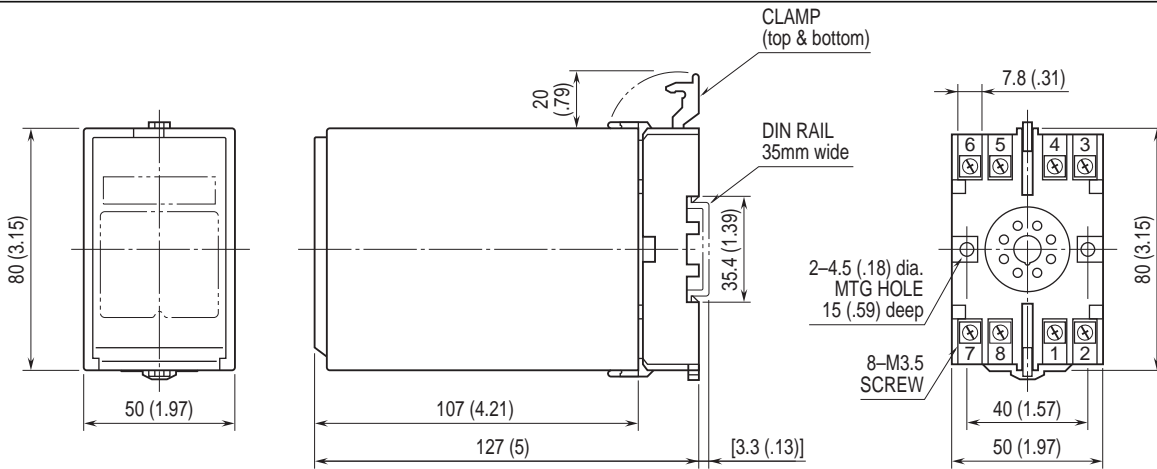

• When mounting, no extra space is needed between units.

TERMINAL ASSIGNMENTS unit: mm (inch)

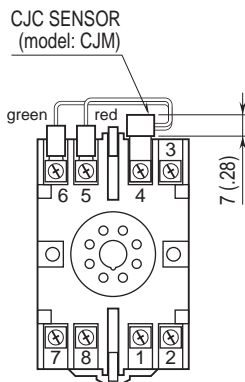

SCHEMATIC CIRCUITRY & CONNECTION DIAGRAM

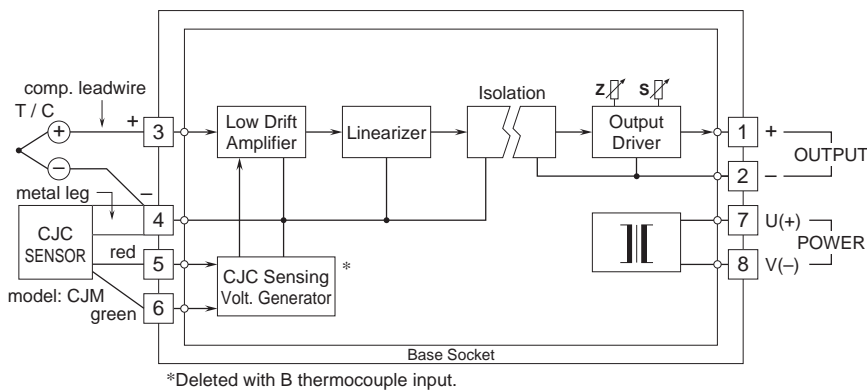



Specifications are subject to change without notice.



幸託有限公司
XIN TOP CORPORATION

TEL : (02)2598-1199
FAX : (02)2596-2331

E-mail : info@xintop.com
Website : www.xintop.com