

**Plug-in Signal Conditioners M-UNIT**

**SIGNAL TRANSMITTER**

(CE, isolated)

**Functions & Features**

- Converting a DC input into two standard process signals
- Fast response type available
- High-density mounting

**Typical Applications**

- Isolation between control room and field instrumentation

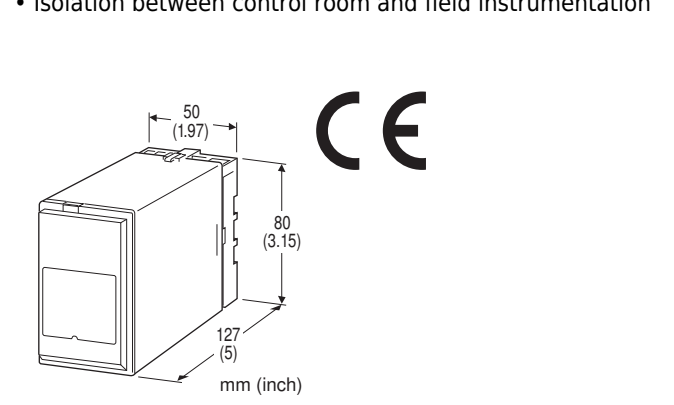

**MODEL: SV-[1][2]-[3][4]**

**ORDERING INFORMATION**

- Code number: SV-[1][2]-[3][4]  
Specify a code from below for each [1] through [4].  
(e.g. SV-6A-B/K/CE/Q)
- Special input and output ranges (For codes Z & 0)
- Specify the specification for option code /Q  
(e.g. /C01/S01)

**[1] INPUT**

**Current**

- A: 4 - 20 mA DC (Input resistance 250 Ω)
- A1: 4 - 20 mA DC (Input resistance 50 Ω)
- B: 2 - 10 mA DC (Input resistance 500 Ω)
- C: 1 - 5 mA DC (Input resistance 1000 Ω)
- D: 0 - 20 mA DC (Input resistance 50 Ω)
- E: 0 - 16 mA DC (Input resistance 62.5 Ω)
- F: 0 - 10 mA DC (Input resistance 100 Ω)
- G: 0 - 1 mA DC (Input resistance 1000 Ω)
- H: 10 - 50 mA DC (Input resistance 100 Ω)
- J: 0 - 10 μA DC (Input resistance 1000 Ω)
- K: 0 - 100 μA DC (Input resistance 1000 Ω)
- GW: -1 - +1 mA DC (Input resistance 1000 Ω)
- FW: -10 - +10 mA DC (Input resistance 100 Ω)
- Z: Specify current (See INPUT SPECIFICATIONS)

**Voltage**

- 1: 0 - 10 mV DC (Input resistance 10 kΩ min.)
- 15: 0 - 50 mV DC (Input resistance 10 kΩ min.)
- 16: 0 - 60 mV DC (Input resistance 10 kΩ min.)
- 2: 0 - 100 mV DC (Input resistance 100 kΩ min.)
- 3: 0 - 1 V DC (Input resistance 1 MΩ min.)
- 4: 0 - 10 V DC (Input resistance 1 MΩ min.)
- 5: 0 - 5 V DC (Input resistance 1 MΩ min.)
- 6: 1 - 5 V DC (Input resistance 1 MΩ min.)
- 4W: -10 - +10 V DC (Input resistance 1 MΩ min.)
- 5W: -5 - +5 V DC (Input resistance 1 MΩ min.)
- 0: Specify voltage (See INPUT SPECIFICATIONS)

**[2] OUTPUT**

**Current**

- A: 4 - 20 mA DC (Load resistance 750 Ω max.)
- B: 2 - 10 mA DC (Load resistance 1500 Ω max.)
- C: 1 - 5 mA DC (Load resistance 3000 Ω max.)
- D: 0 - 20 mA DC (Load resistance 750 Ω max.)
- E: 0 - 16 mA DC (Load resistance 900 Ω max.)
- F: 0 - 10 mA DC (Load resistance 1500 Ω max.)
- G: 0 - 1 mA DC (Load resistance 15 kΩ max.)
- Z: Specify current (See OUTPUT SPECIFICATIONS)

**Voltage**

- 1: 0 - 10 mV DC (Load resistance 10 kΩ min.)
- 2: 0 - 100 mV DC (Load resistance 100 kΩ min.)
- 3: 0 - 1 V DC (Load resistance 3000 Ω min.)
- 4: 0 - 10 V DC (Load resistance 10 kΩ min.)
- 5: 0 - 5 V DC (Load resistance 5000 Ω min.)
- 6: 1 - 5 V DC (Load resistance 5000 Ω min.)
- 4W: -10 - +10 V DC (Load resistance 20 kΩ min.)
- 5W: -5 - +5 V DC (Load resistance 10 kΩ min.)
- 0: Specify voltage (See OUTPUT SPECIFICATIONS)

**[3] POWER INPUT**

**AC Power**

- B: 100 V AC
- C: 110 V AC
- D: 115 V AC
- F: 120 V AC
- G: 200 V AC
- H: 220 V AC
- J: 240 V AC

**DC Power**

- S: 12 V DC
- R: 24 V DC
- V: 48 V DC

**[4] OPTIONS (multiple selections)**

**Response Time (0 - 90 %)**

- blank: Standard (≤ 0.5 sec.)
- /K: Fast Response (Approx. 25 msec.)



**Standards & Approvals (must be specified)**

/CE: CE marking

**Other Options**

blank: none

/Q: Option other than the above (specify the specification)

**SPECIFICATIONS OF OPTION: Q (multiple selections)****COATING (For the detail, refer to M-System's web site.)**

/C01: Silicone coating

/C02: Polyurethane coating

/C03: Rubber coating

**TERMINAL SCREW MATERIAL**

/S01: Stainless steel

**GENERAL SPECIFICATIONS**

Construction: Plug-in

Connection: M3.5 screw terminals

Screw terminal: Chromated steel (standard) or stainless steel

Housing material: Flame-resistant resin (black)

Isolation: Input to output to power

Overrange output: Approx. -10 to +120 % at 1 - 5 V

Zero adjustment: -5 to +5 % (front)

Span adjustment: 95 to 105 % (front)

**INPUT SPECIFICATIONS**

## ■ DC Current:

Shunt resistor attached to the input terminals (0.5 W)

Specify input resistance value for code Z.

## ■ DC Voltage: -30 - +30 V DC

Span: Min. 3 mV, max. 30 V

Offset: Max. 1.5 times span

**Input resistance**Span 3 - 10 mV :  $\geq 10 \text{ k}\Omega$ Span 10 - 100 mV :  $\geq 10 \text{ k}\Omega$ Span 0.1 - 1 V :  $\geq 100 \text{ k}\Omega$ Span  $\geq 1 \text{ V}$  :  $\geq 1 \text{ M}\Omega$ **OUTPUT SPECIFICATIONS**

## ■ DC Current: 0 - 20 mA DC

Minimum span: 1 mA

Offset: Max. 1.5 times span

Load resistance: Output drive 15 V max.

## ■ DC Voltage: -10 - +12 V DC

Minimum span: 5 mV

Offset: Max. 1.5 times span

Load resistance: Output drive 1 mA max. at  $\geq 3 \text{ V}$ **INSTALLATION****Power input**•AC: Operational voltage range: rating  $\pm 10 \%$ ,  
50/60  $\pm 2$  Hz, approx. 2 VA•DC: Operational voltage range: rating  $\pm 10 \%$ ,  
ripple 10 %p-p max., approx. 2 W (80 mA at 24 V)

Operating temperature: -5 to +60°C (23 to 140°F)

Operating humidity: 30 to 90 %RH (non-condensing)

Mounting: Surface or DIN rail

Weight: 400 g (0.88 lbs)

**PERFORMANCE in percentage of span**Accuracy:  $\pm 0.1 \%$ Temp. coefficient:  $\pm 0.015 \%/^{\circ}\text{C}$  ( $\pm 0.008 \%/^{\circ}\text{F}$ )Line voltage effect:  $\pm 0.1 \%$  over voltage rangeInsulation resistance:  $\geq 100 \text{ M}\Omega$  with 500 V DC**Dielectric strength:**

1350 V AC @1 minute (input to output)

2300 V AC @1 minute (input or output to power to ground)

**STANDARDS & APPROVALS****CE conformity:**

EMC Directive (2004/108/EC)

EMI EN 61000-6-4: 2007

EMS EN 61000-6-2: 2005

Low Voltage Directive (2006/95/EC)

EN 61010-1: 2001

Installation Category II

Pollution Degree 2

Input or output to power: Reinforced insulation (300 V)

Input to output: Basic insulation (300 V)



## DIMENSIONS unit: mm (inch)

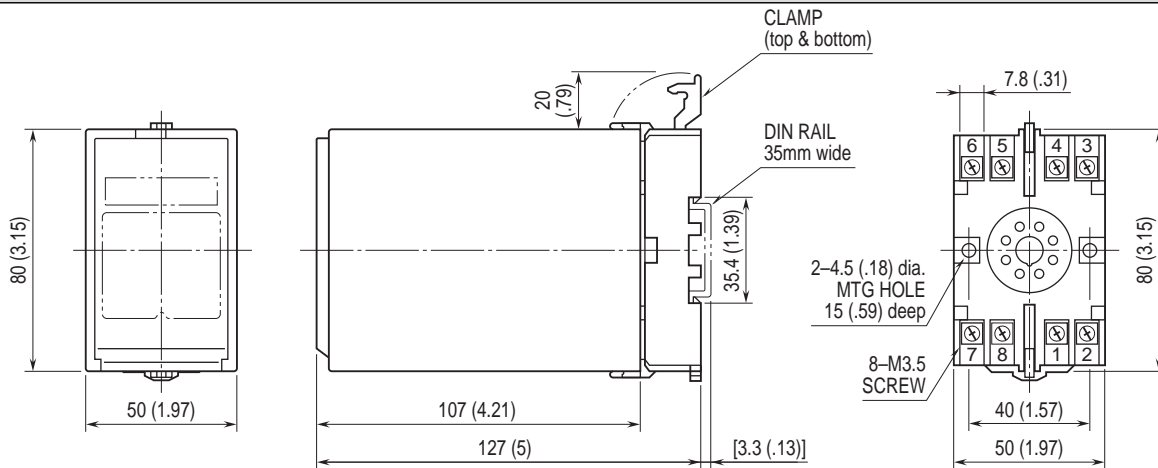

• When mounting, no extra space is needed between units.

## TERMINAL ASSIGNMENTS unit: mm (inch)

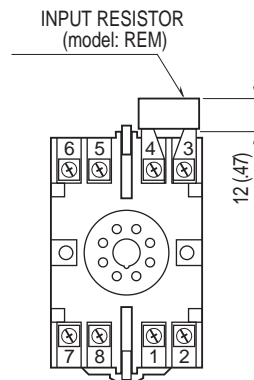

Input shunt resistor attached for current input.

## SCHEMATIC CIRCUITRY & CONNECTION DIAGRAM

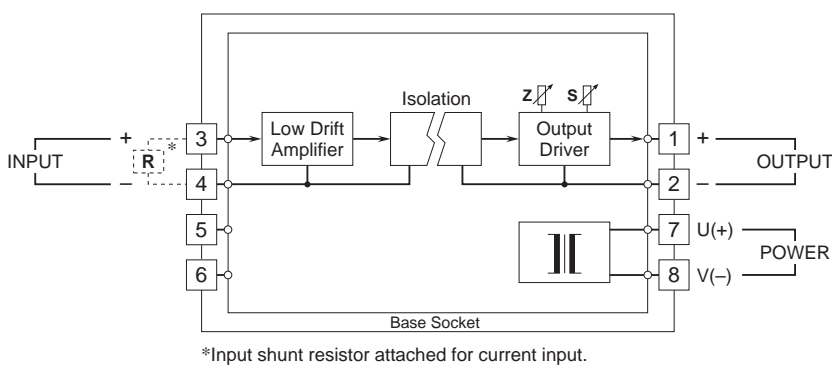

Specifications are subject to change without notice.