

**Plug-in Signal Conditioners M-UNIT**

**ANALOG SUBTRACTOR**

**Functions & Features**

- Accepting two DC inputs and providing a standard process signal proportional to the difference of the two signals
- Isolation up to 2000 V AC
- LCD meter indicates subtracted values (engineering unit display selectable)
- Simple loop test output (0 % and 100 %)
- Highdensity mounting

**Typical Applications**

- Computing differences of two temp., flows, etc.
- DC input transmitter for a power installation (dielectric strength 2000 V AC, 110V DC power)

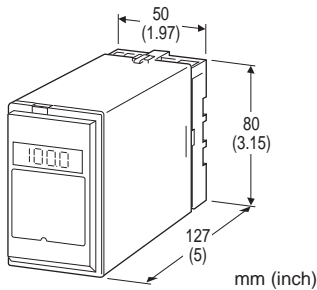

**MODEL: SBS-[1][2]-[3][4]**

**ORDERING INFORMATION**

- Code number: SBS-[1][2]-[3][4]
- Specify a code from below for each [1] through [4]. (e.g. SBS-6A-B/E2/Q)
- Special input and output ranges (For codes Z & O)
- Parameters (e.g.  $K_1 = 2.00$ ,  $K_2 = 0.10$ )
- Specify the specification for option code /Q (e.g. /C01/S01)

**[1] INPUT**

**Current**

- A: 4 - 20 mA DC (Input resistance 250  $\Omega$ )
- A1: 4 - 20 mA DC (Input resistance 50  $\Omega$ )
- B: 2 - 10 mA DC (Input resistance 500  $\Omega$ )
- C: 1 - 5 mA DC (Input resistance 1000  $\Omega$ )
- D: 0 - 20 mA DC (Input resistance 50  $\Omega$ )
- E: 0 - 16 mA DC (Input resistance 62.5  $\Omega$ )
- F: 0 - 10 mA DC (Input resistance 100  $\Omega$ )
- G: 0 - 1 mA DC (Input resistance 1000  $\Omega$ )
- H: 10 - 50 mA DC (Input resistance 100  $\Omega$ )
- J: 0 - 10  $\mu$ A DC (Input resistance 1000  $\Omega$ )

- K: 0 - 100  $\mu$ A DC (Input resistance 1000  $\Omega$ )
- GW: -1 - +1 mA DC (Input resistance 1000  $\Omega$ )
- FW: -10 - +10 mA DC (Input resistance 100  $\Omega$ )
- Z: Specify current (See INPUT SPECIFICATIONS)

**Voltage**

- 1: 0 - 10 mV DC (Input resistance 10 k $\Omega$  min.)
- 15: 0 - 50 mV DC (Input resistance 10 k $\Omega$  min.)
- 16: 0 - 60 mV DC (Input resistance 10 k $\Omega$  min.)
- 2: 0 - 100 mV DC (Input resistance 100 k $\Omega$  min.)
- 3: 0 - 1 V DC (Input resistance 1 M $\Omega$  min.)
- 4: 0 - 10 V DC (Input resistance 1 M $\Omega$  min.)
- 5: 0 - 5 V DC (Input resistance 1 M $\Omega$  min.)
- 6: 1 - 5 V DC (Input resistance 1 M $\Omega$  min.)
- 4W: -10 - +10 V DC (Input resistance 1 M $\Omega$  min.)
- 5W: -5 - +5 V DC (Input resistance 1 M $\Omega$  min.)
- 0: Specify voltage (See INPUT SPECIFICATIONS)

**[2] OUTPUT**

**Current**

- A: 4 - 20 mA DC (Load resistance 750  $\Omega$  max.)
- B: 2 - 10 mA DC (Load resistance 1500  $\Omega$  max.)
- C: 1 - 5 mA DC (Load resistance 3000  $\Omega$  max.)
- D: 0 - 20 mA DC (Load resistance 750  $\Omega$  max.)
- E: 0 - 16 mA DC (Load resistance 900  $\Omega$  max.)
- F: 0 - 10 mA DC (Load resistance 1500  $\Omega$  max.)
- G: 0 - 1 mA DC (Load resistance 15 k $\Omega$  max.)
- Z: Specify current (See OUTPUT SPECIFICATIONS)

**Voltage**

- 1: 0 - 10 mV DC (Load resistance 10 k $\Omega$  min.)
- 2: 0 - 100 mV DC (Load resistance 100 k $\Omega$  min.)
- 3: 0 - 1 V DC (Load resistance 100  $\Omega$  min.)
- 4: 0 - 10 V DC (Load resistance 1000  $\Omega$  min.)
- 5: 0 - 5 V DC (Load resistance 500  $\Omega$  min.)
- 6: 1 - 5 V DC (Load resistance 500  $\Omega$  min.)
- 4W: -10 - +10 V DC (Load resistance 2000  $\Omega$  min.)
- 5W: -5 - +5 V DC (Load resistance 1000  $\Omega$  min.)
- 0: Specify voltage (See OUTPUT SPECIFICATIONS)

**[3] POWER INPUT**

**AC Power**

- B: 100 V AC
- C: 110 V AC
- D: 115 V AC
- F: 120 V AC
- G: 200 V AC
- H: 220 V AC
- J: 240 V AC

**DC Power**

- S: 12 V DC
- R: 24 V DC
- V: 48 V DC



P: 110 V DC (Not selectable with Option /E2)

#### [4] OPTIONS (multiple selections)

##### Signal Indicator

blank: Without

/E: LCD meter (0.0 - 100.0 %)

/E2: LCD display in engineering unit with backlight and the simple loop test output

##### Other Options

blank: none

/Q: Option other than the above (specify the specification)

#### SPECIFICATIONS OF OPTION: Q (multiple selections)

**COATING (For the detail, refer to M-System's web site.)**

/C01: Silicone coating

/C02: Polyurethane coating

/C03: Rubber coating

##### TERMINAL SCREW MATERIAL

/S01: Stainless steel

#### GENERAL SPECIFICATIONS

**Construction:** Plug-in

**Connection:** M3.5 screw terminals

**Screw terminal:** Chromated steel (standard) or stainless steel

**Housing material:** Flame-resistant resin (black)

**Isolation:** Input 1 or input 2 to output to power

**Overrange output:** Approx. -10 to +120 % at 1 - 5 V

**Zero adjustment:** -5 to +5 % (front)

**Span adjustment:** 95 to 105 % (front)

**Equation:** Output =  $K_1 \times \text{Input 1} - K_2 \times \text{Input 2}$

( $K_1 \times \text{Input 1} > K_2 \times \text{Input 2}$ )

$K_1, K_2$ : 0.10 - 2.00 (parameters)

Output, Input 1  $\times K_1$ , Input 2  $\times K_2$ : 0 - 100%

$K_1, K_2$  are ex-factory specified.

**Display scaling:** -10000 - +10000; ex-factory set to 0.00 - 100.00 (%)

**Engineering unit:** %,  $\mu\text{V}$ , mV, V, mA, A,  $^{\circ}\text{C}$ ,  $^{\circ}\text{F}$ ,  $\Omega$ , DEG K, mHz, Hz, kHz, VAC, AAC, mg, g, kg, t, rpm or rps selectable

**Simple loop test output:** 0 % and 100 % signal simulated by selecting the front switch positions.

#### INPUT SPECIFICATIONS

##### ■ DC Current:

Shunt resistor attached to the input terminals (0.5 W)

Specify input resistance value for code Z.

##### ■ DC Voltage: -300 - +300 V DC

**Minimum span:** 3 mV

**Offset:** Max. 1.5 times span

**Input resistance**

Span 3 - 10 mV :  $\geq 10 \text{ k}\Omega$

Span 10 - 100 mV :  $\geq 10 \text{ k}\Omega$

Span 0.1 - 1 V :  $\geq 100 \text{ k}\Omega$

Span  $\geq 1 \text{ V}$  :  $\geq 1 \text{ M}\Omega$

#### OUTPUT SPECIFICATIONS

##### ■ DC Current: 0 - 20 mA DC

**Minimum span:** 1 mA

**Offset:** Max. 1.5 times span

**Load resistance:** Output drive 15 V max.

##### ■ DC Voltage: -10 - +12 V DC

**Minimum span:** 5 mV

**Offset:** Max. 1.5 times span

**Load resistance:** Output drive 10 mA max.; 5 mA for negative voltage output; at  $\geq 0.5 \text{ V}$

#### INSTALLATION

##### Power input

•**AC:** Operational voltage range: rating  $\pm 10 \%$ , 50/60  $\pm 2 \text{ Hz}$ , approx. 2 VA

(approx. 3 VA with Option /E2)

•**DC:** Operational voltage range: rating  $\pm 10 \%$ , or 85 - 150 V for 110 V rating (ripple 10 % p-p max.) approx. 2 W (80 mA at 24 V; approx. 3 W with Option /E2)

**Operating temperature:** -5 to +60 $^{\circ}\text{C}$  (23 to 140 $^{\circ}\text{F}$ )

**Operating humidity:** 30 to 90 %RH (non-condensing)

**Mounting:** Surface or DIN rail

**Weight:** 400 g (0.88 lb)

#### PERFORMANCE in percentage of span

**Accuracy:**  $\pm 0.2 \%$  ( $\pm 0.4 \%$  at  $K_1$  and/or  $K_2 > 1.00$ )

**Display accuracy:**  $\pm (0.2 \%$  of FS + 1 digit)

$\pm (0.4 \%$  of FS + 1 digit) at  $K_1$  and/or  $K_2 > 1.00$

**Simple loop test output setting accuracy:**  $\pm 0.5 \%$

**Temp. coefficient:**  $\pm 0.015 \%$ / $^{\circ}\text{C}$  ( $\pm 0.008 \%$ / $^{\circ}\text{F}$ )

**Response time:**  $\leq 0.5 \text{ sec.}$  (0 - 90 %)

**Line voltage effect:**  $\pm 0.1 \%$  over voltage range

**Insulation resistance:**  $\geq 100 \text{ M}\Omega$  with 500 V DC

**Dielectric strength:** 2000 V AC @ 1 minute (input 1 or input 2 to output to power to ground)



## EXTERNAL VIEW

OPTION /E

OPTION /E2

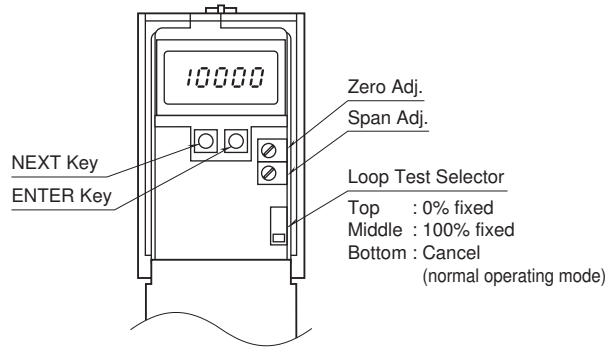
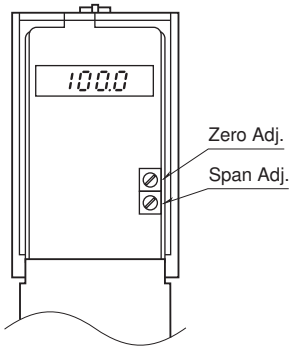

## DIMENSIONS unit: mm (inch)

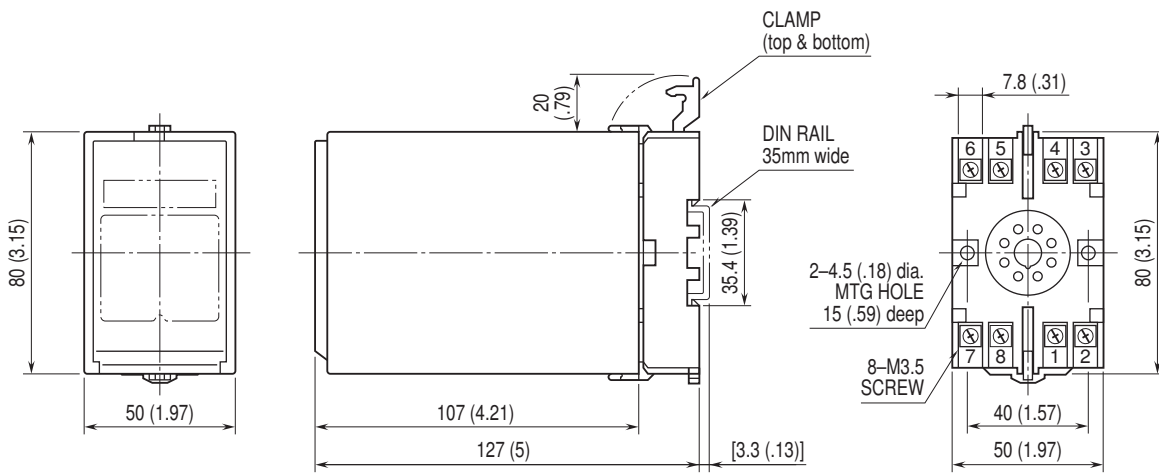

## TERMINAL ASSIGNMENTS unit: mm (inch)

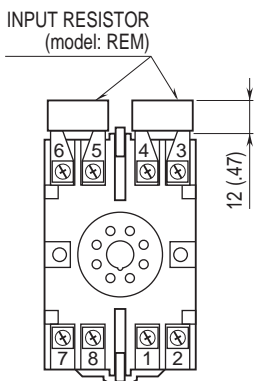

Input shunt resistor attached for current input.

**SCHEMATIC CIRCUITRY & CONNECTION DIAGRAM**

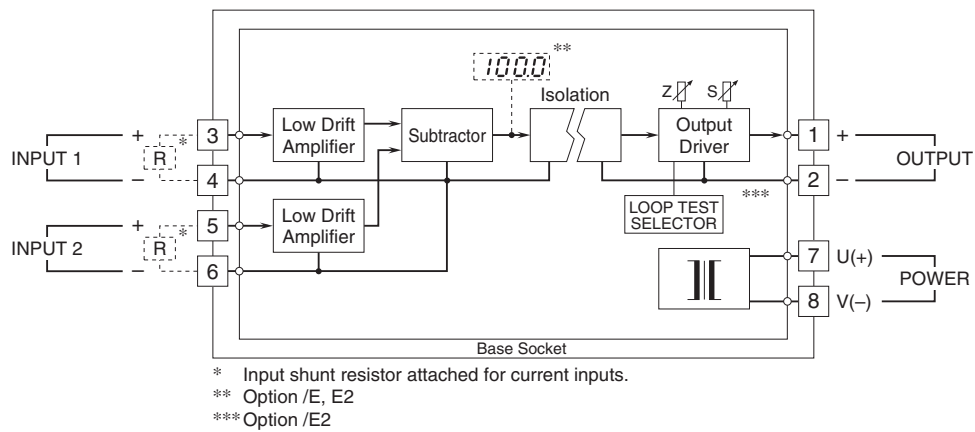

Specifications are subject to change without notice.

