

Plug-in Signal Conditioners M-UNIT

RTD TRANSMITTER

(CE, isolated)

Functions & Features

- Accepting direct input from an RTD and providing two standard process signals
- Linearization
- Burnout protection
- "Active bridge" circuit containing two constant current sources allows large leadwire resistances up to 200 Ω
- Fast response type available
- High-density mounting

Typical Applications

- Long distance transmission between the RTD and the transmitter
- Combination with intrinsic safety barriers

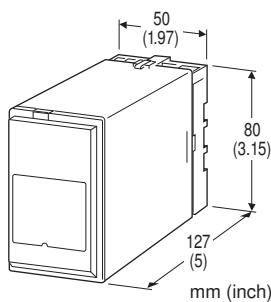

MODEL: RBS-[1][2]-[3][4]

ORDERING INFORMATION

- Code number: RBS-[1][2]-[3][4]
Specify a code from below for each [1] through [4].
(e.g. RBS-1A-B/BL/CE/Q)
- Temperature range (e.g. 0 - 500°C)
- Special output range (For codes Z & 0)
- Specify the specification for option code /Q
(e.g. /C01/S01)

[1] INPUT RTD (2- or 3-wire)

1: JPt 100 (JIS'89)

(Usable range: -200 to +500°C, -328 to +932°F; min.span: 50°C, 90°F)

3: Pt 100 (JIS'89)

(Usable range: -200 to +650°C, -328 to +1202°F; min.span: 50°C, 90°F)

4: Pt 100 (JIS'97, IEC)

(Usable range: -200 to +650°C, -328 to +1202°F; min.span: 50°C, 90°F)

5: Pt 50 Ω (JIS'81)

(Usable range: -200 to +500°C, -328 to +932°F; min.span: 100°C, 180°F)

6: Ni 508.4 Ω

(Usable range: -50 to +200°C, -58 to +392°F; min.span: 30°C, 54°F)

0: Specify

Note: Consult M-System for 2-wire RTD

[2] OUTPUT

Current

A: 4 - 20 mA DC (Load resistance 750 Ω max.)

B: 2 - 10 mA DC (Load resistance 1500 Ω max.)

C: 1 - 5 mA DC (Load resistance 3000 Ω max.)

D: 0 - 20 mA DC (Load resistance 750 Ω max.)

E: 0 - 16 mA DC (Load resistance 900 Ω max.)

F: 0 - 10 mA DC (Load resistance 1500 Ω max.)

G: 0 - 1 mA DC (Load resistance 15 k Ω max.)

Z: Specify current (See OUTPUT SPECIFICATIONS)

Voltage

1: 0 - 10 mV DC (Load resistance 10 k Ω min.)

2: 0 - 100 mV DC (Load resistance 100 k Ω min.)

3: 0 - 1 V DC (Load resistance 3000 Ω min.)

4: 0 - 10 V DC (Load resistance 10 k Ω min.)

5: 0 - 5 V DC (Load resistance 5000 Ω min.)

6: 1 - 5 V DC (Load resistance 5000 Ω min.)

0: Specify voltage (See OUTPUT SPECIFICATIONS)

[3] POWER INPUT

AC Power

B: 100 V AC

C: 110 V AC

D: 115 V AC

F: 120 V AC

G: 200 V AC

H: 220 V AC

J: 240 V AC

DC Power

S: 12 V DC

R: 24 V DC

V: 48 V DC

[4] OPTIONS (multiple selections)

Response Time (0 - 90 %)

blank: Standard (\leq 0.5 sec.)

/K: Fast Response (Approx. 25 msec.)

Burnout

blank: Upscale burnout

/BL: Downscale burnout

Standards & Approvals (must be specified)

/CE: CE marking

Other Options

blank: none

/Q: Option other than the above (specify the specification)



SPECIFICATIONS OF OPTION: Q (multiple selections)

COATING (For the detail, refer to M-System's web site.)

/C01: Silicone coating

/C02: Polyurethane coating

/C03: Rubber coating

TERMINAL SCREW MATERIAL

/S01: Stainless steel

GENERAL SPECIFICATIONS

Construction: Plug-in

Connection: M3.5 screw terminals

Screw terminal: Chromated steel (standard) or stainless steel

Housing material: Flame-resistant resin (black)

Isolation: Input to output to power

Overrange output: Approx. -10 to +120 % at 1 - 5 V

Zero adjustment: -5 to +5 % (front)

Span adjustment: 95 to 105 % (front)

Linearization: Standard

INPUT SPECIFICATIONS

Maximum leadwire resistance: 200 Ω per wire (3-wire)

Sensing current: 2 mA

OUTPUT SPECIFICATIONS

■ DC Current: 0 - 20 mA DC

Minimum span: 1 mA

Offset: Max. 1.5 times span

Load resistance: Output drive 15 V max.

■ DC Voltage: -10 - +12 V DC

Minimum span: 5 mV

Offset: Max. 1.5 times span

Load resistance: Output drive 1 mA max. at ≥ 3 V

INSTALLATION

Power input

•AC: Operational voltage range: rating ± 10 %, 50/60 ± 2 Hz, approx. 2 VA

•DC: Operational voltage range: rating ± 10 %, ripple 10 %p-p max., approx. 2 W (80 mA at 24 V)

Operating temperature: -5 to +60°C (23 to 140°F)

Operating humidity: 30 to 90 %RH (non-condensing)

Mounting: Surface or DIN rail

Weight: 350 g (0.77 lbs)

PERFORMANCE in percentage of span

Accuracy: ± 0.2 %

Temp. coefficient: ± 0.015 %/°C (± 0.008 %/°F)

Burnout response: ≤ 10 sec.

Line voltage effect: ± 0.1 % over voltage range

Insulation resistance: ≥ 100 M Ω with 500 V DC

Dielectric strength:

1350 V AC @1 minute (input to output)

2300 V AC @1 minute (input or output to power to ground)

STANDARDS & APPROVALS

CE conformity:

EMC Directive (2004/108/EC)

EMI EN 61000-6-4: 2007

EMS EN 61000-6-2: 2005

Low Voltage Directive (2006/95/EC)

EN 61010-1: 2001

Installation Category II

Pollution Degree 2

Input or output to power: Reinforced insulation (300 V)

Input to output: Basic insulation (300 V)



EXTERNAL DIMENSIONS & TERMINAL ASSIGNMENTS unit: mm (inch)

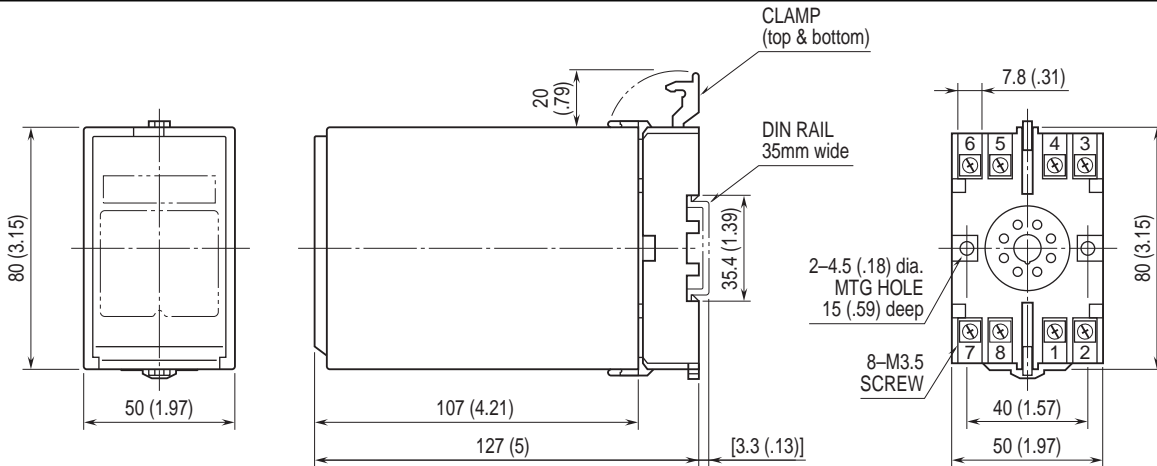

• When mounting, no extra space is needed between units.

SCHEMATIC CIRCUITRY & CONNECTION DIAGRAM

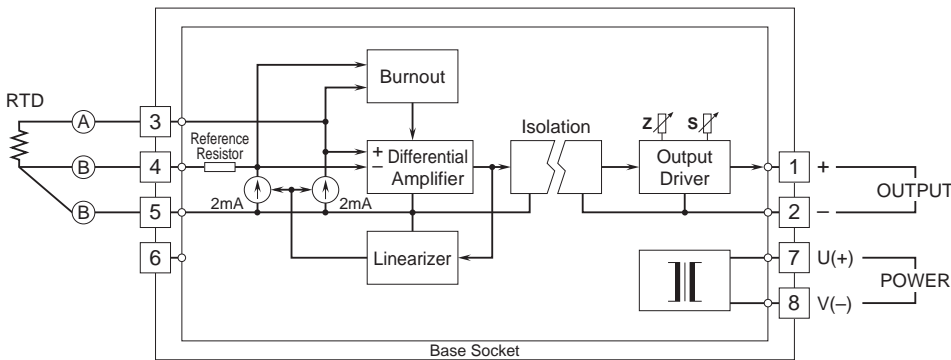

Specifications are subject to change without notice.