

Remote I/O R8 Series

THERMOCOUPLE INPUT MODULE

(2 points, isolated)

Functions & Features

- Accepts direct input from an thermocouple and provides an isolated, linearized DC signal compact size remote I/O module

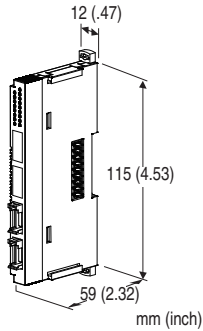

MODEL: R8-TS2

ORDERING INFORMATION

- Code number: R8-TS2

RELATED PRODUCTS

- PC configurator software (model: R8CFG) Downloadable at M-System's web site.
- A dedicated cable is required to connect the module to the PC. Please refer to the internet software download site or the users manual for the PC configurator for applicable cable types.

GENERAL SPECIFICATIONS

Connection

- **Input:** 4-pin e-CON connector
PWB connector XN2D-1474-S002 (Omron)
Recommended cable connector XN2A-1470 (Omron)
Applicable wire size 0.08 mm² (AWG28) - 0.5 mm² (AWG20)
Outer sheath diameter: max. 1.5 dia
(The cable connector is not included in the package. Refer to the specifications of the product.)

- **Excitation supply, internal bus:**

- Connected to internal bus connector
- **Internal power:** Supplied from internal bus connector

Isolation: Input 1 to input 2 to exc. supply to internal bus or internal power

Zero adjustments: -32000 - 32000 (PC programming)

Span adjustments: -32000 - 32000 (PC programming)

Configurator software can handle 100 - 200°C as numerical value of 0 - 10000

Input sensor setting: DIP switches on the side or with PC

Burnout detection: Selectable with the side DIP SW

Linearization: Standard

Cold Junction Compensation: CJC sensor incorporated

Module address: With rotary switch

Converted data range:

- Engineering unit value (°C, K) × 10 (integer)
- Engineering unit value (°F)

Terminating resistor: Built-in (DIP Switch, default: disable)

Status indicator: Bi-color (red/green) LED; Refer to the instruction manual.

Input status indicators: Red LED; Refer to the instruction manual.

INPUT SPECIFICATIONS

Input resistance: 10kΩ minimum

Burnout sensing: 0.2 μA

T/C	BURNOUT INDICATION (°C)		CONFORMANCE RANGE (°C)
	Downscale	Upscale	
K (CA)	-272	+1472	-150 to +1370
E (CRC)	-272	+1100	-170 to +1000
J (IC)	-260	+1300	-180 to +1200
T (CC)	-272	+ 500	-170 to + 400
B (RH)	24	1920	400 to 1760
R	-100	+1860	200 to 1760
S	-100	+1860	0 to 1760
C (WRe 5-26)	-52	+2416	0 to 2315
N	-272	+1400	-130 to +1300
U	-252	+ 700	-200 to +600
L	-252	+1000	-200 to +900
P (Platinel II)	-52	+1496	0 to 1395
(PR)	-52	+1860	0 to 1760

T/C	BURNOUT INDICATION (°F)		CONFORMANCE RANGE (°F)
	Downscale	Upscale	
K (CA)	-458	+2682	-238 to +2498
E (CRC)	-458	+2012	-274 to +1832
J (IC)	-436	+2372	-292 to +2192
T (CC)	-458	+932	-274 to +752
B (RH)	75	3488	752 to 3200
R	-148	+3380	392 to 3200
S	-148	+3380	32 to 3200
C (WRe 5-26)	-62	+4381	32 to 4199
N	-458	+2552	-202 to +2372
U	-422	+1292	-328 to +1112
L	-422	+1832	-328 to +1652
P (Platinel II)	-62	+2725	32 to 2543
(PR)	-62	+3380	32 to 3200

INSTALLATION

Max. current consumption: 100 mA

Operating temperature: -10 to +55°C (14 to 131°F)

Operating humidity: 30 to 90 %RH (non-condensing)

Atmosphere: No corrosive gas or heavy dust



Mounting: DIN rail
Weight: 60 g (2.12 oz)

PERFORMANCE

Conversion accuracy: $\pm 1^{\circ}\text{C}$ ($\pm 1.8^{\circ}\text{F}$) except $\pm 2.0^{\circ}\text{C}$ ($\pm 3.6^{\circ}\text{F}$) for B, R, S, C, PR
Conversion rate: 100 msec. per channel
Data allocation: 2
Module addresses in use: 1
Cold junction compensation error:
 $\pm 3^{\circ}\text{C}$ at $25 \pm 10^{\circ}\text{C}$
 $\pm 5.4^{\circ}\text{F}$ at $77 \pm 18^{\circ}\text{F}$
Temp. coefficient: $\pm 0.03\ \%/^{\circ}\text{C}$ ($\pm 0.02\ \%/^{\circ}\text{F}$)
Burnout response time: ≤ 1 sec.
Insulation resistance: $\geq 100\ \text{M}\Omega$ with 500 V DC
Dielectric strength:
 1000 V AC @ 1 minute (input 1 to input 2 to exc. supply to internal bus or internal power to ground)

STANDARDS & APPROVALS

CE conformity:
 EMC Directive (2004/108/EC)
 EMI EN 61000-6-4: 2007
 EMS EN 61000-6-2: 2005

EXTERNAL VIEW

■ FRONT VIEW

■ SIDE VIEW

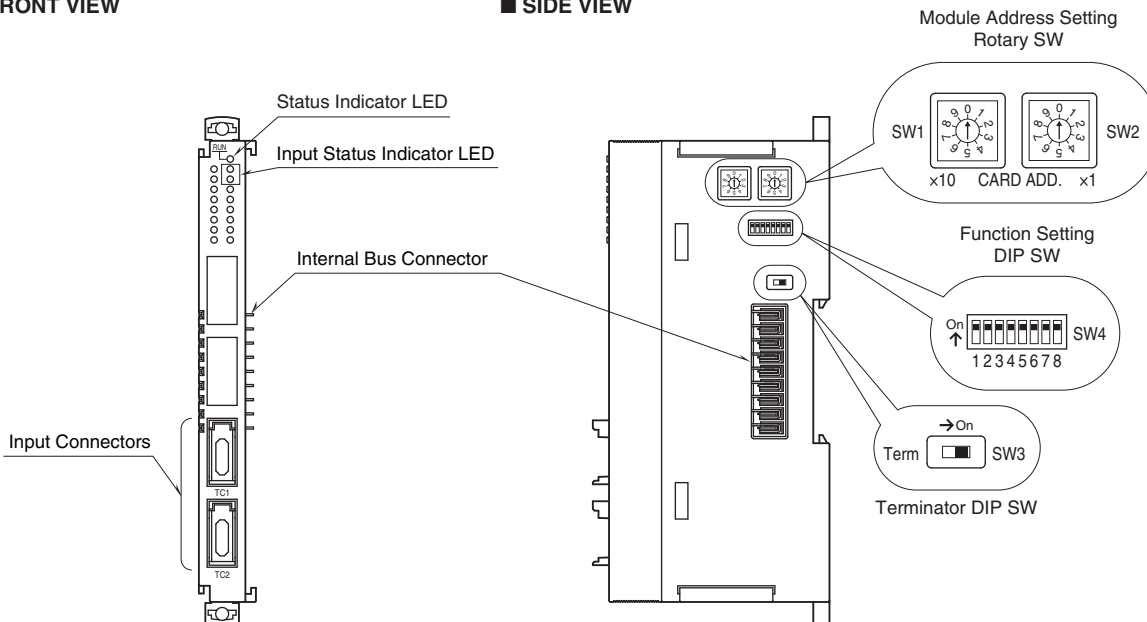

OPERATING MODE SETTING

(*) Factory setting

Caution ! - SW4-4 through 4-6 are unused. Be sure to turn off unused ones.

■ MODULE ADDRESS

The left switch determines the tenth place digit, while the right switch does the ones place digit of the address.

Address is selected between 0 to 31.

(Factory setting: 0)

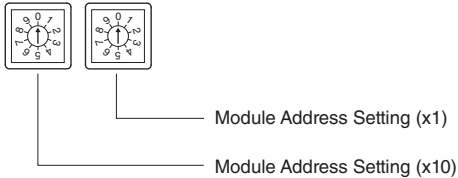

■ THERMOCOUPLE TYPE

Same setting for all channels. Use PC Configurator to set independent settings per channel.

T/C	SW4		
	1	2	3
K (CA) (*)	OFF	OFF	OFF
E (CRC)	ON	OFF	OFF
J (IC)	OFF	ON	OFF
T (CC)	ON	ON	OFF
B (RH)	OFF	OFF	ON
R	ON	OFF	ON
S	OFF	ON	ON
C (WRe 5-26)	ON	ON	ON

Use PC Configurator Software (model: R8CFG) to set N, U, L, P (Platinel II) and PR thermocouples.

■ Burnout

BURNOUT	SW4
	7
Upscale (*)	OFF
Downscale	ON

■ Configuration Mode

CONFIGURATION MODE	SW4
	8
DIP switch setting (*)	OFF
PC Configurator and communication	ON

■ Terminator DIP SW

TERMINATOR SW	SW3
Without (*)	OFF
With	ON

DIMENSIONS unit: mm (inch)

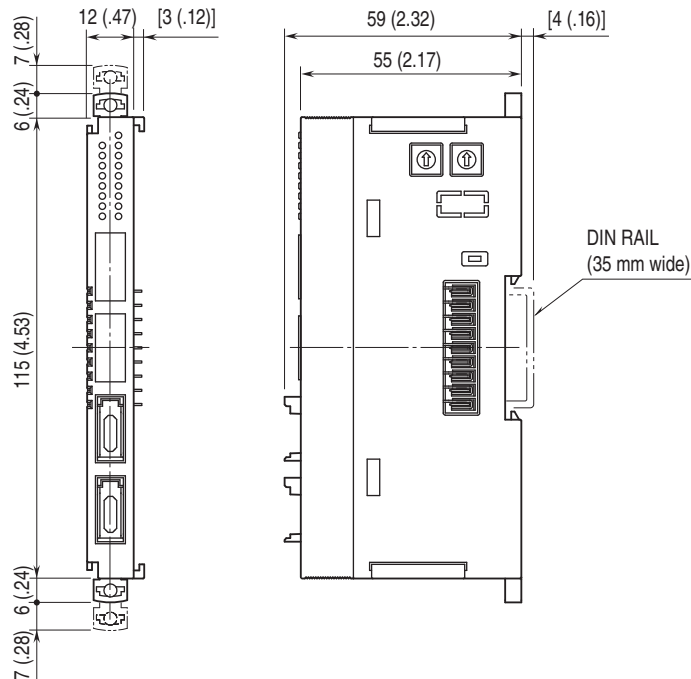

SCHEMATIC CIRCUITRY & CONNECTION DIAGRAM

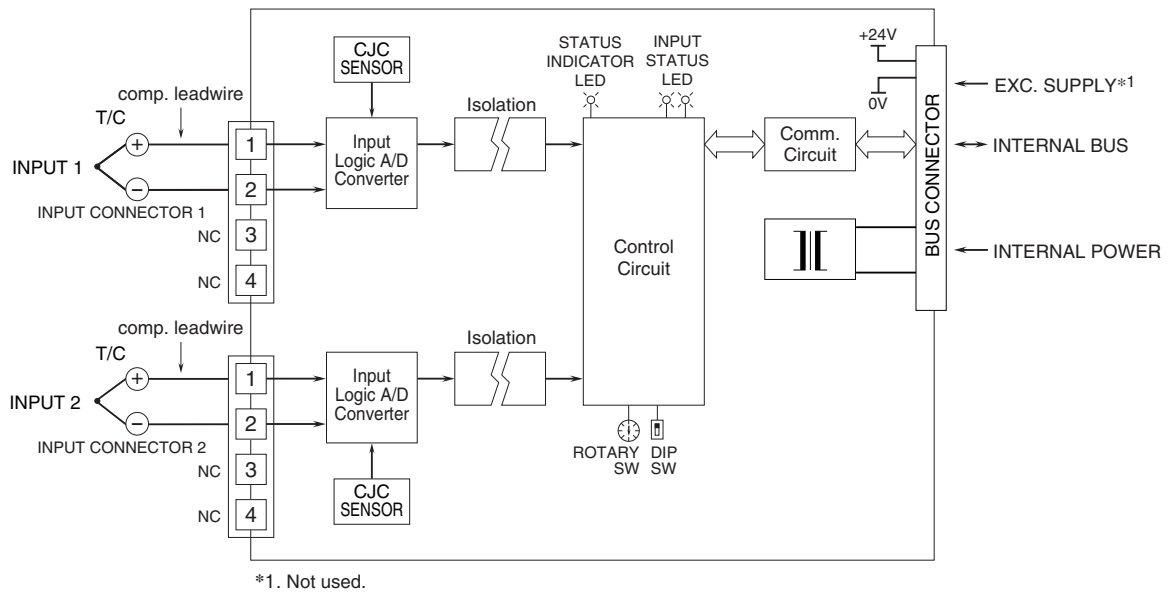

Specifications are subject to change without notice.