

Remote I/O R8 Series

POWER/NETWORK MODULE

(Modbus use)

Functions & Features

- Free combination of analog and discrete I/O
- Space-saving

Typical Applications

- Remote I/O for DCS and PLC

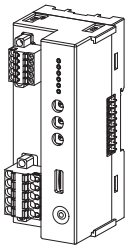

MODEL: R8-NM1-R

ORDERING INFORMATION

- Code number: R8-NM1-R

MODULE TYPE

NM1: Modbus

POWER INPUT

DC power

R: 24 V DC

(Operational voltage range: $\pm 10\%$; ripple 10 %p-p max.)

PACKAGE INCLUDES...

- Protective cover

GENERAL SPECIFICATIONS

Connection

- Power input or excitation supply: Tension clamp (Front Twin connection)

Applicable wire size: 0.2 - 2.5 mm²

Stripped length: 10 mm

- Modbus: Tension clamp (Front Twin connection)

Applicable wire size: 0.2 - 1.5 mm²

Stripped length: 10 mm

- Internal bus or internal power or excitation supply: Via connector

Max. number of I/O modules: 16

(Max. consumption current of I/O modules: 1.6 A)

Isolation: Modbus to internal bus or internal power or power input to exc. supply to FE1

Status indicators: Power, Run, Error, SD, RD

Data allocation: Mode 1, 2

MODBUS COMMUNICATION

Communication: Half-duplex, asynchronous, no procedure

Standard: Conforms to RS-485, EIA

Transmission distance: 500 meters max.

Transmission media: Shielded twisted-pair cable (CPEV-S 0.9 dia.)

Transmission setting: DIP switch, rotary switch.

Data: RTU (Binary) or ASCII

Parity: none, even or odd

Baud rate: 4800, 9600, 19.2 k, 38.4 k (bps)

Node address: With rotary switch

Terminating resistor: Built-in (DIP Switch, default: disable)

INSTALLATION

Power consumption

- DC: Approx. 12 W 24 V DC (@ output current 1.6 A)

Internal power

- DC: 5 V DC
- Operational current: 1.6 A

Excitation supply output

- DC: 24 V DC $\pm 10\%$
 - Operational current: 10 A
- (Power output current consumption must be under 10 A)

Operating temperature: -10 to +55°C (14 to 131°F)

Operating humidity: 30 to 90 %RH (non-condensing)

Atmosphere: No corrosive gas or heavy dust

Mounting: DIN rail

Weight: 160 g (0.35 lb)

PERFORMANCE

Insulation resistance: $\geq 100\text{ M}\Omega$ with 500 V DC

Dielectric strength: 1500 V AC @ 1 minute

(Modbus to internal bus or internal power to power input to exc. supply to FE1)

STANDARDS & APPROVALS

CE conformity:

EMC Directive (2004/108/EC)

EMI EN 61000-6-4: 2007

EMS EN 61000-6-2: 2005



EXTERNAL VIEW

FRONT VIEW

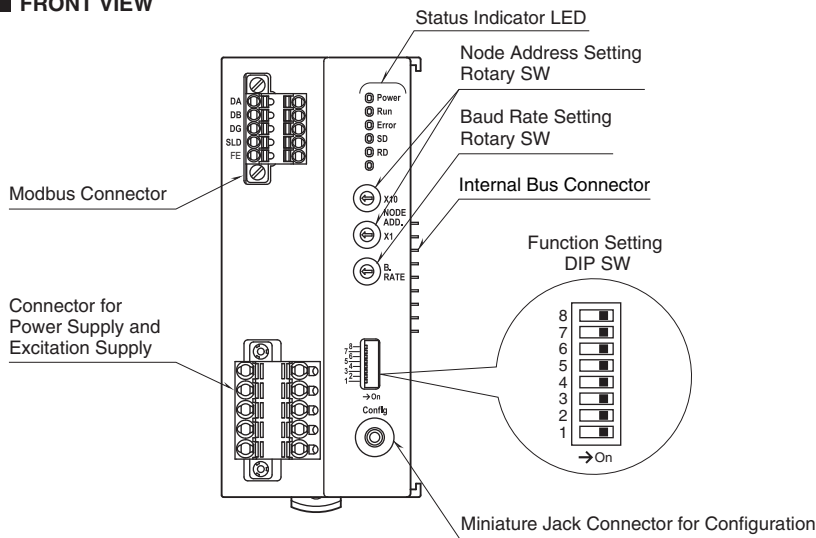

TOP VIEW

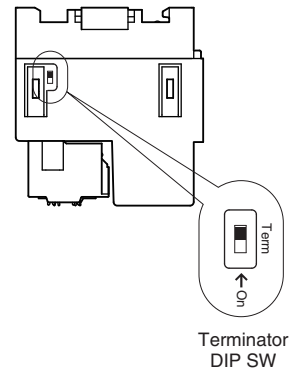

STATUS INDICATOR LED

ID	COLOR	FUNCTION
Power	Green	ON when the internal 5V power is in normal status.
Run	Green	ON with normal communication *1
Error	Red	ON when abnormal data is received.
SD	Green	ON with data transmitting
RD	Green	ON with data receiving

*1. Run LED turns off when no command is received from the master device.

CONNECTION DIAGRAMS

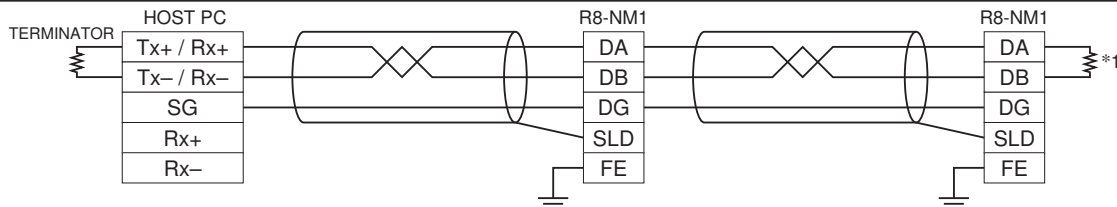

*1. Turn on the terminator DIP switch to activate the internal terminating resistor.

POWER SUPPLY, EXCITATION SUPPLY CONNECTOR TERMINAL ASSIGNMENT

Printed-circuit board connector (Phoenix Contact)

Header: MSTBV2,5/5-GF-5,08AU

Plug component: TFKC2,5/5-STF-5,08AU

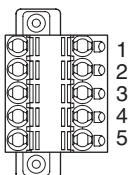

PIN No.	ID	FUNCTION
1	24V	Power supply 24V DC
2	0V	Power supply 0V DC
3	+	Excitation supply 24V DC
4	-	Excitation supply 0V DC
5	FE1	Grounding

■ NETWORK CONNECTOR ASSIGNMENT

Printed-circuit board connector (Phoenix Contact)

Header: MC1,5/5-GF-3,5

Plug component: TFMC1,5/5-STF-3,5

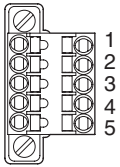

PIN No.	ID	FUNCTION
1	DA	DA
2	DB	DB
3	DG	DG
4	SLD	Shield
5	FE	FE

MODBUS FUNCTION CODES & SUPPORTED CODES

■ Data and Control Functions

CODE	NAME		
01	Read Coil Status	X	Digital output from the slave
02	Read Input Status	X	Status of digital inputs to the slave
03	Read Holding Registers	X	General purpose register within the slave
04	Read Input Registers	X	Collected data from the field by the slave
05	Force Single Coil	X	Digital output from the slave
06	Preset Single Registers	X	General purpose register within the slave
07	Read Exception Status		
08	Diagnostics	X	
09	Program 484		
10	Poll 484		
11	Fetch Comm. Event Counter		Fetch a status word and an event counter
12	Fetch Comm. Event Log		A status word, an event counter, a message count and a field of event bytes
13	Program Controller		
14	Poll Controller		
15	Force Multiple Coils	X	Digital output from the slave
16	Preset Multiple Registers	X	General purpose register within the slave
17	Report Slave ID		Slave type / 'RUN' status
18	Program 884/M84		
19	Reset Comm. Link		
20	Read General Reference		
21	Write General Reference		
22	Mask Write 4X Register		
23	Read/Write 4X Register		
24	Read FIFO Queue		

■ Exception Codes

CODE	NAME		
01	Illegal Function	X	Function code is not allowable for the slave
02	Illegal Data Address	X	Address is not available within the slave
03	Illegal Data Value	X	Data is not valid for the function
04	Slave Device Failure	X	
05	Acknowledge	X	
06	Slave Device Busy	X	
07	Negative Acknowledge	X	
08	Memory Parity Error		

■ DIAGNOSTIC SUBFUNCTIONS

CODE	NAME		
00	Return Query Data	X	Loop back test
01	Restart Comm. Option	X	Reset the slave and clear all counters
02	Return Diagnostic Register	X	Contents of the diagnostic data (2 bytes)
03	Change ASCII Input Delimiter	X	Delimiter character of ASCII message
04	Force Listen Only Mode	X	Force the slave into Listen Only Mode



MODBUS I/O ASSIGNMENTS

The DIP SW located at the front of the module switches the unit's data allocation mode.

In the Data Allocation Mode 1, one (1) word is assigned per module. The second channel of analog I/O modules cannot be used. When I/O module of 32-bit data is used, set the Data Allocation Mode to 2.

In the Data Allocation Mode 2, two (2) words are assigned per module regardless of whether the second word area is required or not.

For discrete I/O, 16-channel area is automatically assigned to each module. With a 4-channel module, the bits assigned to ch. 5 through 16 remain "0."

A 4-point analog I/O module takes two addresses per module. For example with the model R8-SV4N located at the module address 5, the inputs 1 and 2 are assigned to the address 5, and the inputs 3 and 4 are to the address 6. Do not assign another module to the address 6. All 4 inputs (input 1 through 4) can be used with Data Allocation Mode 2, while only the inputs 1 and 3 can be used with Data Allocation Mode 1. R8-NM1 Version 1.04 or later can deal with I/O mixed modules. The version of R8-NM1 is confirmed with configurator software (model: R8CFG).

Note: DO NOT access addresses other than mentioned below. Such access may cause problems such as inadequate operation.

Coil (0X)	1 – 16	Module address 0	Do 1 – 16
	17 – 32	Module address 1	Do 1 – 16
	33 – 48	Module address 2	Do 1 – 16
	49 – 64	Module address 3	Do 1 – 16
	:	:	:
Inputs (1X)	497 – 512	Module address 31	Do 1 – 16
	1 – 16	Module address 0	Di 1 – 16
	17 – 32	Module address 1	Di 1 – 16
	33 – 48	Module address 2	Di 1 – 16
	49 – 64	Module address 3	Di 1 – 16
	:	:	:
	497 – 512	Module address 31	Di 1 – 16
513 – 544	Active module map		
545 – 560	Status		

■ Data Allocation Mode 1

Input Registers (3X)	1	Module address 0	Ai 1 (INT)
	2	Module address 1	Ai 1 (INT)
	3	Module address 2	Ai 1 (INT)
	4	Module address 3	Ai 1 (INT)
	:	:	:
	32	Module address 31	Ai 1 (INT)
	33, 34	Module address 0	Ai 1 (Float)
	35, 36	Module address 1	Ai 1 (Float)
	37, 38	Module address 2	Ai 1 (Float)
	39, 40	Module address 3	Ai 1 (Float)
Holding Registers (4X)	:	:	:
	95, 96	Module address 31	Ai 1 (Float)
	1	Module address 0	Ao 1 (INT)
	2	Module address 1	Ao 1 (INT)
	3	Module address 2	Ao 1 (INT)
	4	Module address 3	Ao 1 (INT)
	:	:	:
	32	Module address 31	Ao 1 (INT)
	33, 34	Module address 0	Ao 1 (Float)
	35, 36	Module address 1	Ao 1 (Float)
37, 38	Module address 2	Ao 1 (Float)	
39, 40	Module address 3	Ao 1 (Float)	
:	:	:	
95, 96	Module address 31	Ao 1 (Float)	

■ Data Allocation Mode 2

Input Registers (3X)	1	Module address 0	Ai 1 (INT)
	2	Module address 0	Ai 2 (INT)
	3	Module address 1	Ai 1 (INT)
	4	Module address 1	Ai 2 (INT)
	:	:	:
	63	Module address 31	Ai 1 (INT)
	64	Module address 31	Ai 2 (INT)
	65, 66	Module address 0	Ai 1 (Float)
	67, 68	Module address 0	Ai 2 (Float)
	69, 70	Module address 1	Ai 1 (Float)
Holding Registers (4X)	71, 72	Module address 1	Ai 2 (Float)
	:	:	:
	189, 190	Module address 31	Ai 1 (Float)
	191, 192	Module address 31	Ai 2 (Float)
	1	Module address 0	Ao 1 (INT)
	2	Module address 0	Ao 2 (INT)
	3	Module address 1	Ao 1 (INT)
	4	Module address 1	Ao 2 (INT)
	:	:	:
	63	Module address 31	Ao 1 (INT)
64	Module address 31	Ao 2 (INT)	
65, 66	Module address 0	Ao 1 (Float)	
67, 68	Module address 0	Ao 2 (Float)	
69, 70	Module address 1	Ao 1 (Float)	
71, 72	Module address 1	Ao 2 (Float)	
:	:	:	
189, 190	Module address 31	Ao 1 (Float)	
191, 192	Module address 31	Ao 2 (Float)	



■ ACTIVE MODULE MAP

Indicates the I/O modules are mounted to the board. When the module is mounted, the corresponding bit turns to "1."

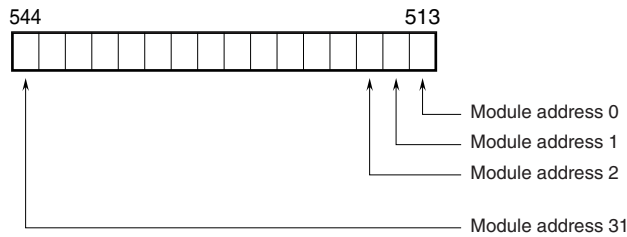

■ STATUS

Communication status data. When one or more I/O modules are mounted on the base, the corresponding bit turns to "0."

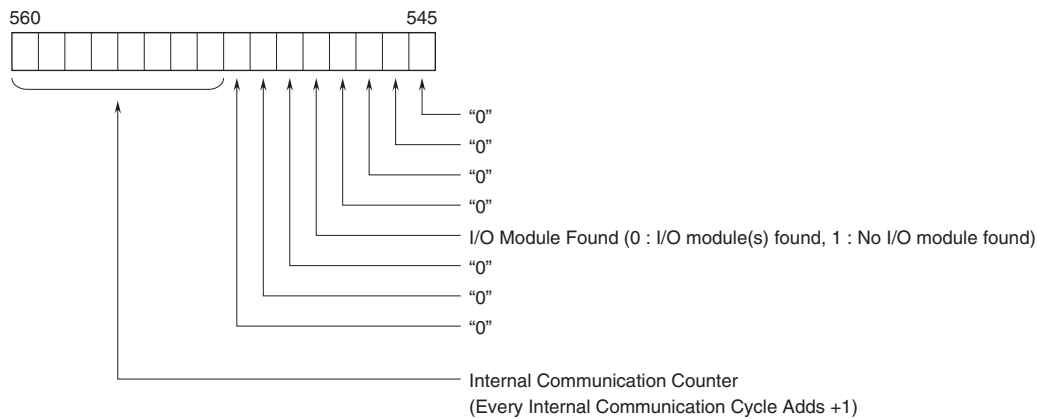

I/O DATA DESCRIPTIONS

■ ANALOG DATA

0 to 100% of the selected I/O range is converted into 0 to 10000 (binary).
Negative values are represented in 2's complements.



■ PULSE DATA (32-bit data)

32-bit binary data is used for pulse data.
Lower 16 bits are allocated from the lowest address to higher ones, higher 16 bits in turn.
32-bit data cannot be accessed using floating addresses.



■ ANALOG DATA (TEMPERATURE DATA)



16-bit binary data

With °C, K temperature unit, raw data is multiplied by 10. For example, 25.5°C is converted into 255.

With °F temperature unit, the integer section of raw data is directly converted into the data.

For example, 135.4°F is converted into 135.

Minus temperature is converted into negative values, represented in 2's complements.



■ DISCRETE DATA

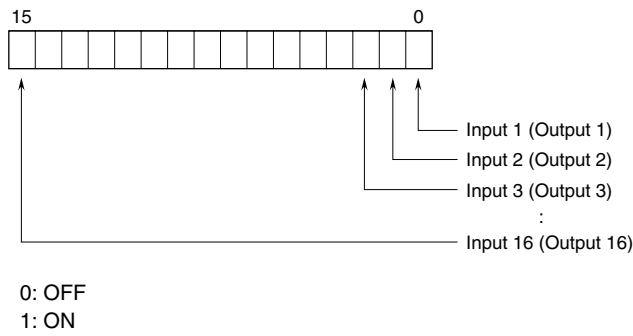

For I/O mixed modules shown below, interlock status is assigned to input 1 (to 3) in addition to output 1 to 16.
(Available with R8-NM1 Version 1.04 or later)

R8-DCM16ALZ	Input 1	Global interlock
R8-DCM16ALK	Input 1	Global interlock
	Input 2	Individual interlock 1
	Input 3	Individual interlock 2
R8-DCM16ALH	Input 1	Global interlock
	Input 2	Partial interlock 1
	Input 3	Partial interlock 2

EXTERNAL DIMENSIONS & TERMINAL ASSIGNMENTS unit: mm (inch)

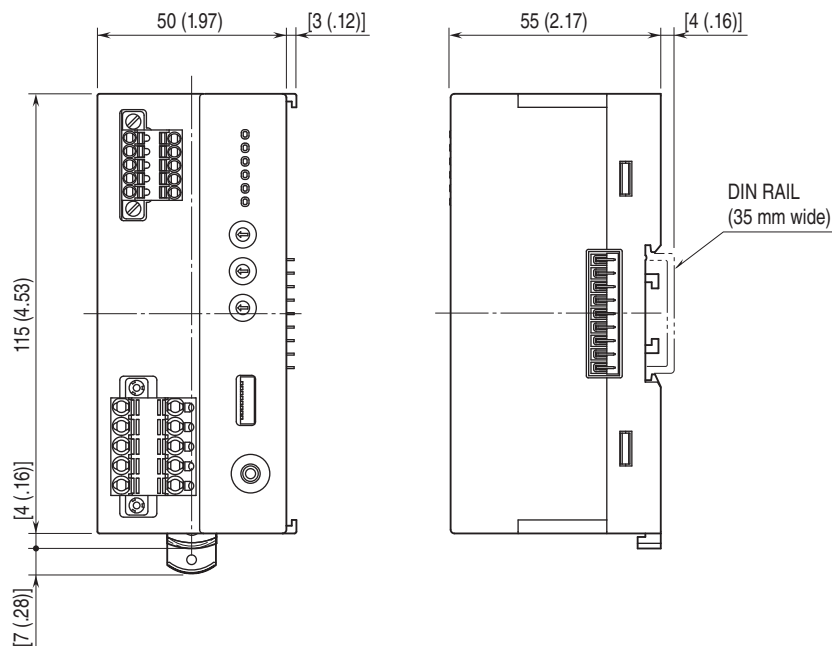

SCHEMATIC CIRCUITRY & CONNECTION DIAGRAM

Note: In order to improve EMC performance, bond the FE1 terminal to ground.

Caution: FE1 terminal is NOT a protective conductor terminal.

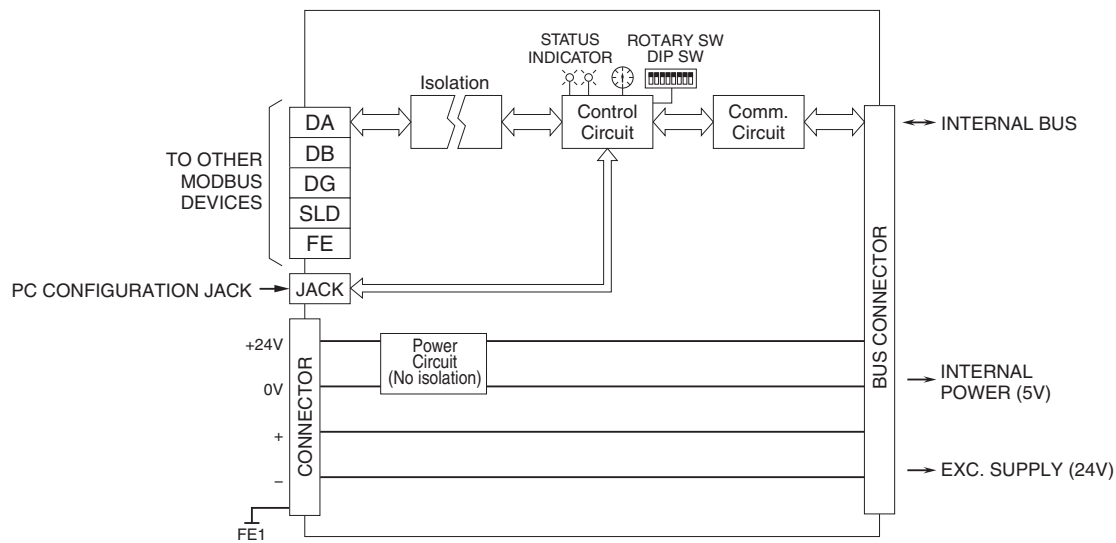

Specifications are subject to change without notice.

