

Remote I/O R7 Series

MULTI POWER MONITORING MODULE

(Clamp-on current sensor CLSE, Modbus)

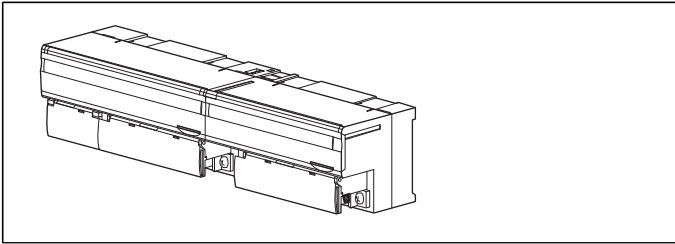

ORDERING INFORMATION

- Basic module: R7MWTU-2[1]1-AD4
Specify a code from below for [1].
(e.g. R7MWTU-221-AD4)

- Extension module: R7MWTU-EA8

BASIC MODULE: R7MWTU-2[1]1-AD4

CONFIGURATION

2: Single-phase / 2-wire and 3-wire,
3-phase / 3-wire and 4-wire

[1] NO. OF SYSTEMS

1: 1 system, Di / Pi x 4 (internal power 5 V)
(no connection with extension module)
2: 2 systems

INPUT

1: 240 V AC / CLSE

POWER INPUT

Universal

AD4: 100 - 240 V AC / 110 - 240 V DC (universal)
(Operational voltage range 85 - 264 V AC, 50 - 60 Hz /
99 - 264 V DC, ripple 10 %p-p max.)

EXTENSION MODULE: R7MWTU-EA8

I/O TYPE

EA8: Di / Pi, 8 points (internal power 5 V)

FUNCTIONS & FEATURES

The R7MWTU is a Multi Power Monitoring Module for Modbus.

The R7MWTU uses clamp-on current sensors, there is no

need of current transformers.

Current sensors are easy to install in existing systems. Wide input range of 5 to 600 A is available.

All measured values, counter values, display mode, setting data are stored in the non-volatile memory when power is off.

A 'basic' module can be attached with an 'extension' module (except R7MWTU-211-AD4) because of this, it is able to use it as 2-circuit power and 8 discrete inputs module.

RELATED PRODUCTS

- PC configurator software (model: PMCFG)

Downloadable at M-System's web site.

A dedicated cable is required to connect the module to the PC. Please refer to the internet software download site or the users manual for the PC configurator for applicable cable types.

- Clamp-on current sensor (model: CLSE)

The clamp-on current sensors, not included in this product package, must be ordered separately. Required number depends upon the system configuration.

PACKAGE INCLUDES...

- Terminating resistor (110 Ω , 0.25 W)

GENERAL SPECIFICATIONS

Connection: M3 screw terminals (torque 0.5 N·m)

Recommended solderless terminal: Refer to the drawing on the end of this section.

Applicable wire size: 0.3 to 0.75 mm²

Configuration: Single phase/2-wire and 3-wire, 3-phase/3-wire balanced/unbalanced load, 3-phase/4-wire balanced/unbalanced load

Screw terminal: Nickel-plated steel

Isolation: Sensor core to sensor output or current input or voltage input to discrete input to Modbus or FG to power

Measured variables

Voltage: 1-N, 2-N, 3-N, 1-2, 2-3, 3-1

Current: 1, 2, 3, N

Active / reactive / apparent power: 1, 2, 3, Σ

Power factor: 1, 2, 3, Σ

Frequency

Active energy: Incoming / outgoing

Reactive energy: Incoming / outgoing / lag (inductive) /lead (capacitive)

Apparent energy

Active / reactive / apparent power intervals (demand)

Average (demand) current: 1, 2, 3, N

Harmonic contents: Σ

Voltage: 1-N, 2-N, 3-N, 1-2, 2-3, 3-1

Current: 1, 2, 3, N



Max. and min. values

Demand history: 1 to 4

Operating mode setting: Configurator software and DIP switch setting; connection, balanced/unbalanced, clamp-on sensor type (refer to the manual for details)

Status indicator LED: PWR

■ Recommended terminal size (unit: mm)

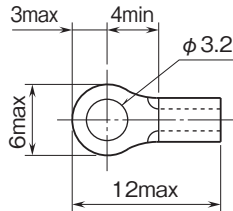

MODBUS COMMUNICATION

Communication: Half-duplex, asynchronous, no procedure

Standard: Conforms to RS-485, EIA

Transmission distance: 500 meters max.

Baud rate: 4.8 to 38.4 kbps max.

Protocol: Modbus - RTU or Modbus - ASCII

Max. number of nodes: 31 (excluding master)

Node address setting: 1 - 99 (with rotary switch) (factory default setting: 00)

Baud rate setting: With rotary switch 38.4 kbps (default) 19.2 kbps, 9600 bps, 4800 bps

Status indicator LED: RUN, ERR, SD, RD

INPUT SPECIFICATIONS

Frequency: 50 / 60 Hz (45 - 65 Hz)

• Voltage Input

Rated voltage

Line-to-line (delta voltage): 240 V

Line-neutral (phase voltage): 138 V

Consumption VA: $\leq U_{LN}^2 / 300 \text{ k}\Omega / \text{phase}$

Overload capacity: 200 % of rating for 10 sec., 120 % continuous

Selectable primary voltage range: 50 - 400 000 V

• Current Input

CLSE-R5: 0 - 5 A AC

CLSE-05: 0 - 50 A AC

CLSE-10: 0 - 100 A AC

CLSE-20: 0 - 200 A AC

CLSE-40: 0 - 400 A AC

CLSE-60: 0 - 600 A AC

Overload capacity: 120 % continuous, 500 % for 10 sec.

Selectable primary current range: 1 - 20 000 A (only with CLSE-R5, refer to the configurator settings)

Operational range

Current: 0 - 120 % of the rating

Voltage: 10 - 120 % of the rating

Apparent power: $\leq 120 \%$ of the rating

Active/reactive power: $\pm 120 \%$ of the rating

Frequency: 45 - 65 Hz

Power factor: ± 1

■ Discrete input

Common: Negative common

Maximum frequency: 10 Hz

Minimum pulse width: 50 msec.

Totalized pulse range: 0 - 999 999 999

Count at overflow: Reset and restart at '1.'

Detecting voltage/current: 5 V DC / 5 mA approx.

Detecting levels: $\leq 5 \text{ k}\Omega / \leq 2 \text{ V}$ for ON;

$\geq 100 \text{ k}\Omega / 4 \text{ V}$ for OFF

Operation mode: Discrete and pulse counter

INSTALLATION

Power consumption

• AC:

Basic module: $< 5 \text{ VA}$

Basic with extension module: $< 6 \text{ VA}$

• DC:

Basic module: $< 1.5 \text{ W}$

Basic with extension module: $< 2 \text{ W}$

Operating temperature: -10 to +55°C (14 to 131°F)

Storage temperature: -20 to +65°C (-4 to +149°F)

Operating humidity: 30 to 90 %RH (non-condensing)

Atmosphere: No corrosive gas or heavy dust

Mounting: DIN rail

Weight:

Basic module: 200 g (0.44 lbs)

Extension module: 90 g (0.2 lbs)

PERFORMANCE

Accuracy (at 10 - 35°C or 50 - 35°F, 45 - 65 Hz)

Add the accuracy of the current sensor for overall values.

Voltage: $\pm 0.5 \%$ of the rating

Current: $\pm 0.5 \%$ of the rating

Power: $\pm 1.0 \%$ of the rating

Power factor: $\pm 1.5 \%$

Frequency: $\pm 0.1 \%$ of the rating

Energy: $\pm 2.0 \%$ of the rating (range 5 - 100 %, PF 1)

Harmonic contents: $\pm 2.0 \%$ of the rating

The described accuracy levels are ensured at the input 1 % or more for phase 2 current with 3-phase/3-wire unbalanced load, for neutral current with 3-phase/4-wire unbalanced load, and neutral current with 1-phase/3-wire.

Sampling time:

Frequency: $\leq 1 \text{ sec.}$

Other: $\leq 500 \text{ msec.}$

Insulation resistance: $\geq 100 \text{ M}\Omega$ with 500 V DC

Dielectric strength:

2000 V AC @ 1 minute (current input or voltage input or



discrete input to Modbus or FG to input power)
 1000 V AC @ 1 minute (current input or voltage input to
 discrete input)

EXTERNAL VIEW

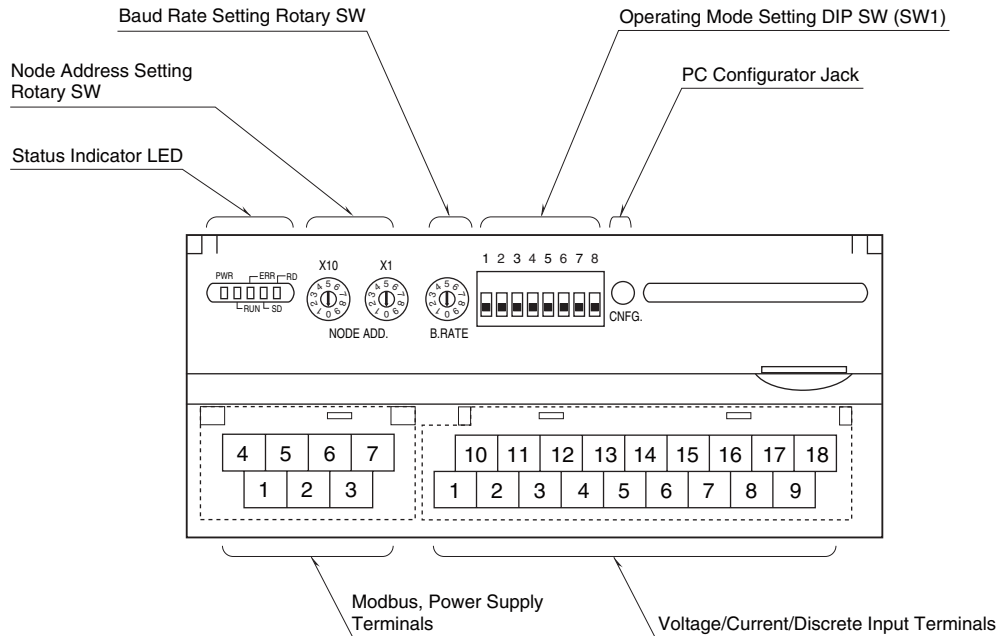

■ STATUS INDICATOR LED

LED	COLOR	STATUS	OPERATION
PWR	Red	ON	Normal operating
		Blink ≈0.5 Hz	No input or input overflow
		Blink ≈2 Hz	Setting error or device abnormality
		OFF	Internal power 5V abnormality
RUN	Red	ON	Normal communication
ERR	Red	ON	Receiving data error
SD	Red	ON	Sending data
RD	Red	ON	Receiving data

TERMINAL CONNECTIONS

System / Application	Terminal	System / Application	Terminal
Single phase / 2-wire		Single phase / 3-wire Three phase / 3-wire unbalanced load (2CT)	
Three phase / 3-wire, balanced load		Three phase / 4-wire, balanced load	
Three phase / 4-wire, unbalanced load			

Caution: Use CLSE for CT.
Grounding is unnecessary for low-voltage circuit.

CONNECTION DIAGRAMS

POWER SUPPLY, Modbus TERMINAL ASSIGNMENT

4	5	6	7
DA	DG	U(+)	V(-)
1	2	3	
DB	SLD	FG	

- 1. DB -
- 2. SLD Shield
- 3. FG FG
- 4. DA -
- 5. DG -
- 6. U (+) Power input (+)
- 7. V (-) Power input (-)

MASTER CONNECTION

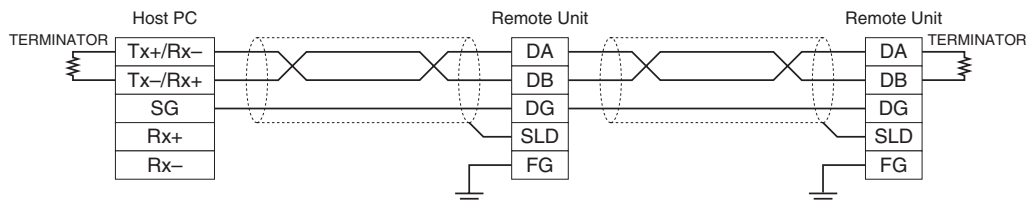

Be sure to connect the terminating resistor included in the product package to the unit at both ends of transmission line.
The terminator must be connected across DA and DB.
The Host PC can be located other than at the extreme ends of transmission line.



TERMINAL ASSIGNMENTS

■ BASIC MODULE

• 1 Circuit, 4 point discrete

10	11	12	13	14	15	16	17	18
P3	NC	NC	1K	2K	3K	DI1+	DI3+	COM
1	2	3	4	5	6	7	8	9
P1	P2	N	1L	2L	3L	DI2+	DI4+	COM

PIN No.	ID	FUNCTION	PIN No.	ID	FUNCTION
1	P1	Voltage Input P1	10	P3	Voltage Input P3
2	P2	Voltage Input P2	11	NC	Unused
3	N	Voltage Input N	12	NC	Unused
4	1ch 1L	1ch current input 1L	13	1ch 1K	1ch current input 1K
5	1ch 2L	1ch current input 2L	14	1ch 2K	1ch current input 2K
6	1ch 3L	1ch current input 3L	15	1ch 3K	1ch current input 3K
7	DI2 +	Discrete input 2	16	DI1 +	Discrete input 1
8	DI4 +	Discrete input 4	17	DI3 +	Discrete input 3
9	COM	Discrete input common	18	COM	Discrete input common

• 2 Circuits

10	11	12	13	14	15	16	17	18
P3	NC	NC	1K	2K	3K	1K	2K	3K
1	2	3	4	5	6	7	8	9
P1	P2	N	1L	2L	3L	1L	2L	3L

PIN No.	ID	FUNCTION	PIN No.	ID	FUNCTION
1	P1	Voltage Input P1	10	P3	Voltage Input P3
2	P2	Voltage Input P2	11	NC	Unused
3	N	Voltage Input N	12	NC	Unused
4	1ch 1L	1ch current input 1L	13	1ch 1K	1ch current input 1K
5	1ch 2L	1ch current input 2L	14	1ch 2K	1ch current input 2K
6	1ch 3L	1ch current input 3L	15	1ch 3K	1ch current input 3K
7	2ch 1L	2ch current input 1L	16	2ch 1K	2ch current input 1K
8	2ch 2L	2ch current input 2L	17	2ch 2K	2ch current input 2K
9	2ch 3L	2ch current input 3L	18	2ch 3K	2ch current input 3K

■ EXTENSION MODULE

6	7	8	9	10
COM	DI1+	DI3+	DI5+	DI7+
1	2	3	4	5
COM	DI2+	DI4+	DI6+	DI8+

PIN No.	ID	FUNCTION	PIN No.	ID	FUNCTION
1	COM	Common	6	COM	Common
2	DI2 +	Discrete input 2	7	DI1 +	Discrete input 1
3	DI4 +	Discrete input 4	8	DI3 +	Discrete input 3
4	DI6 +	Discrete input 6	9	DI5 +	Discrete input 5
5	DI8 +	Discrete input 8	10	DI7 +	Discrete input 7

EXTERNAL DIMENSIONS & TERMINAL ASSIGNMENTS unit: mm (inch)

■ BASIC MODULE

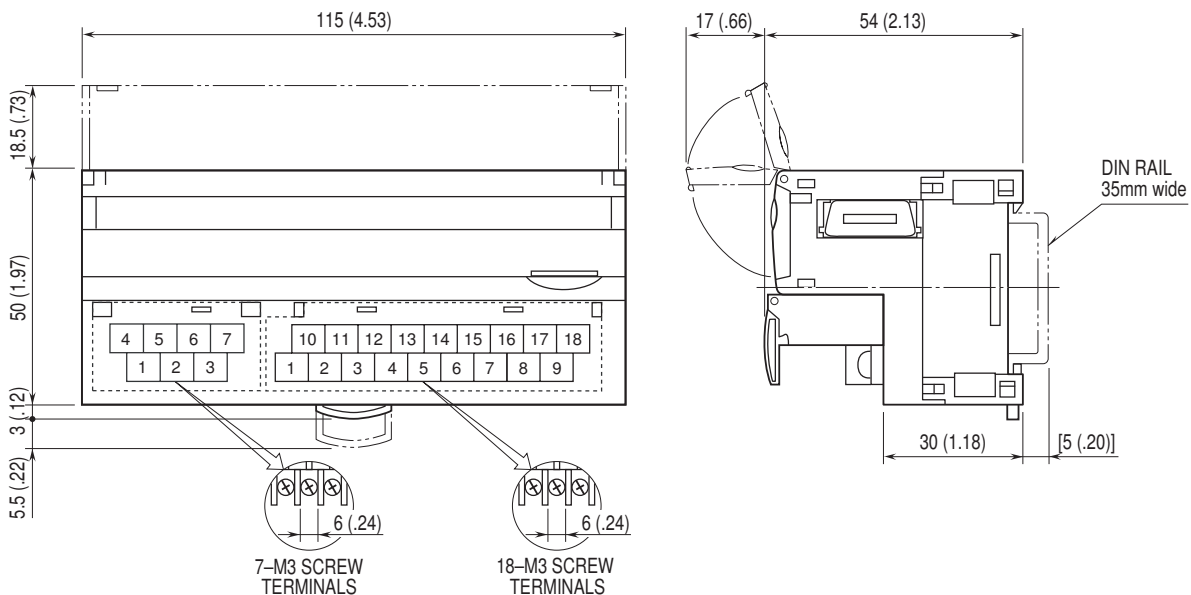

EXTENSION MODULES

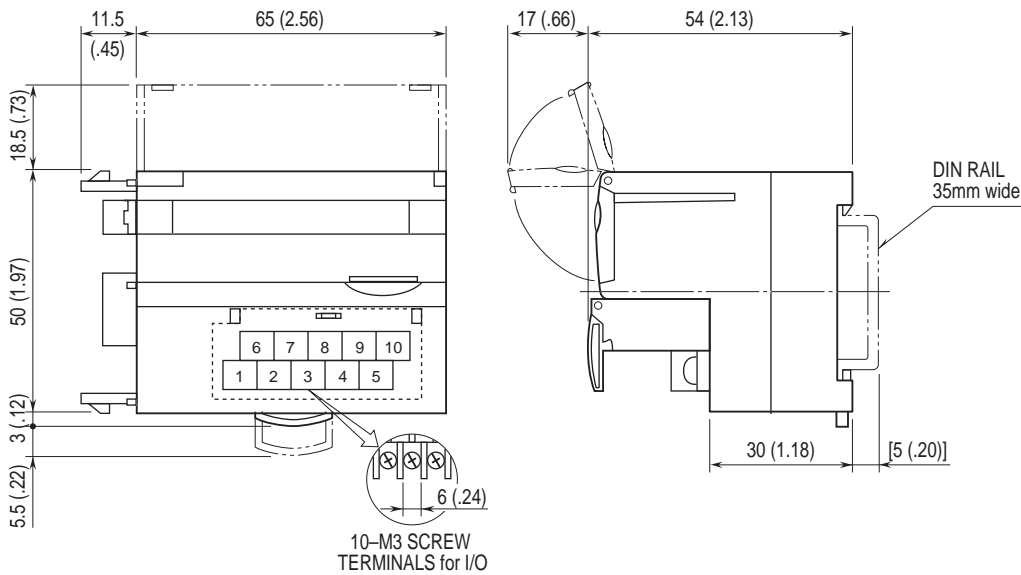

SCHEMATIC CIRCUITRY & CONNECTION DIAGRAM

BASIC MODULE

- 1 Circuit, 4 point discrete

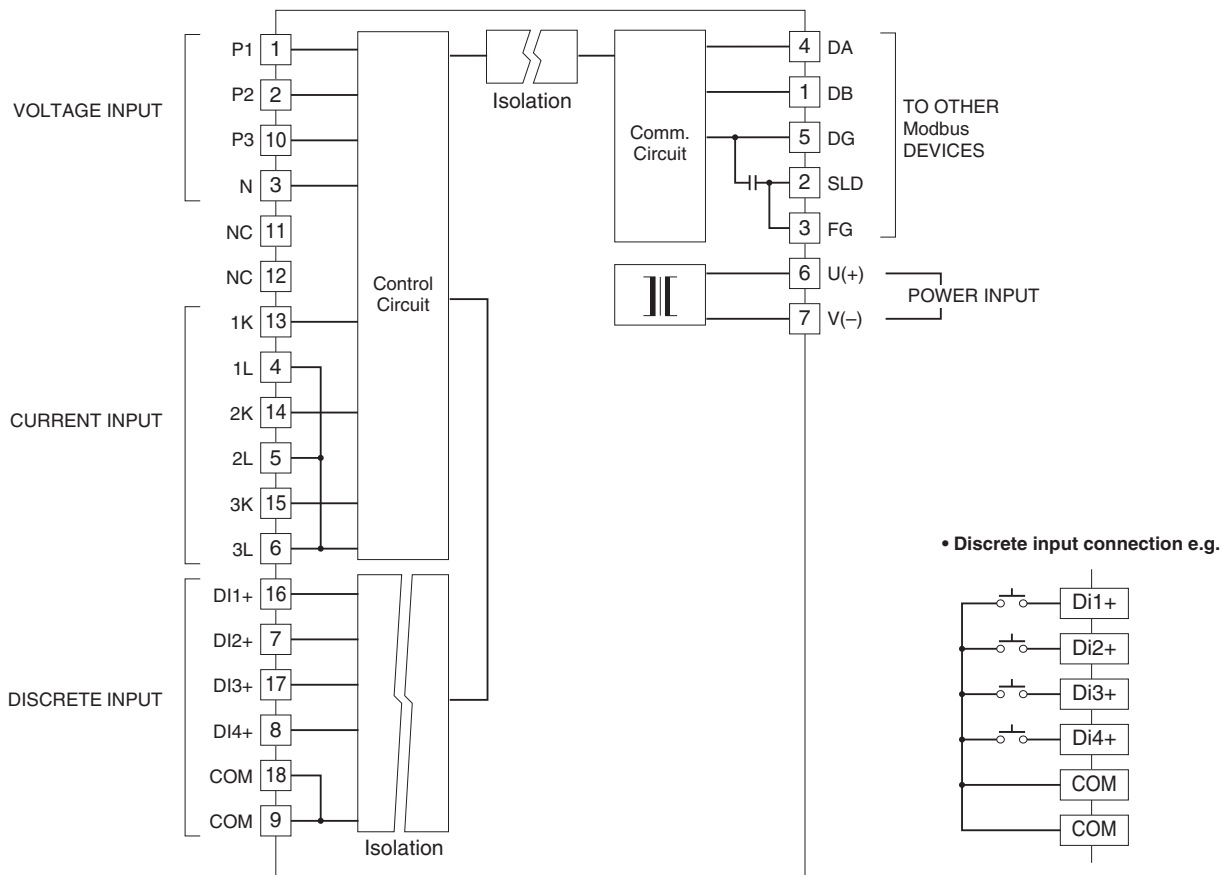

• 2 Circuits

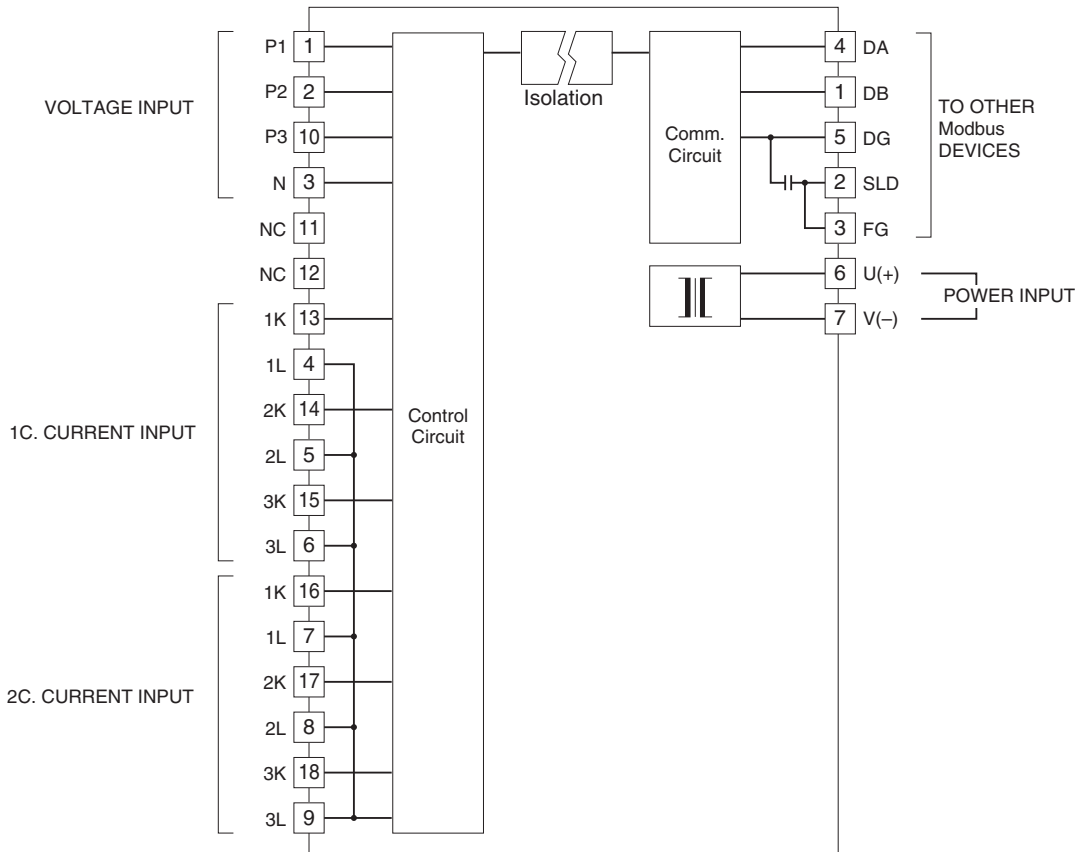

■ EXTENSION MODULE

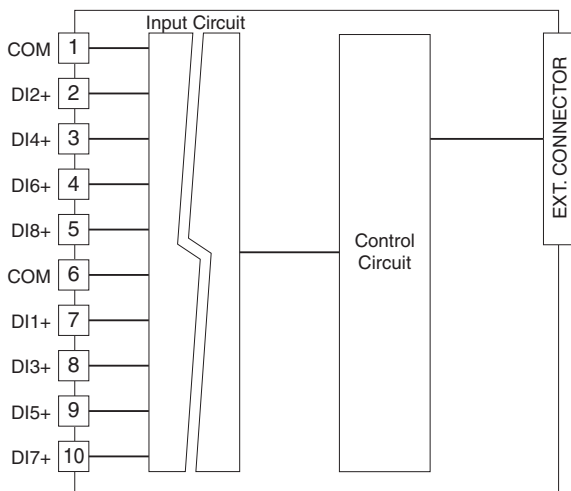

Specifications are subject to change without notice.

