

Remote I/O R7 Series

MECHATROLINK I/O MODULE

(MECHATROLINK-I/-II)

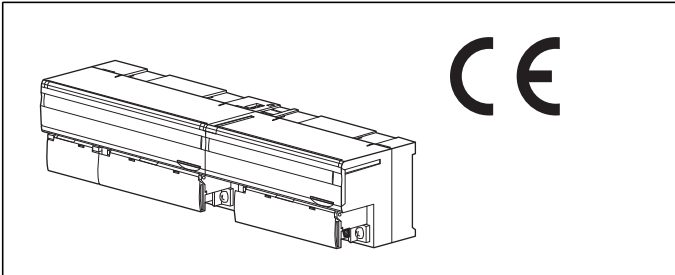

ORDERING INFORMATION

- Basic module: R7ML-[1]-R
Specify a code from below for [1].
(e.g. R7ML-DC16A-R)
- Extension module: R7ML-[1]
Specify a code from below for [1].
(e.g. R7ML-EC16B)

BASIC MODULE: R7ML-[1]-R

[1] I/O TYPE

- DA16:** Discrete input, 16 points
DC16A: NPN transistor output, 16 points
DC16B: PNP transistor output, 16 points
DC16D: PNP transistor output, 16 points, shortcircuit protection
SV4: DC voltage/current input (10 V/20 mA), 4 points
(CE not available)
TS4: Thermocouple input, 4 points (CE not available)
RS4: RTD input, 4 points (CE not available)
YV2: DC voltage output, 2 points (CE not available)
YS2: DC current output, 2 points (CE not available)

POWER INPUT

DC power
R: 24 V DC

EXTENSION MODULE: R7ML-[1]

[1] I/O TYPE

- EA8:** Discrete input, 8 points (CE not available)
EA16: Discrete input, 16 points (CE not available)
EC8A: NPN transistor output, 8 points (CE not available)
EC16A: NPN transistor output, 16 points (CE not available)
EC8B: PNP transistor output, 8 points (CE not available)
EC16B: PNP transistor output, 16 points (CE not available)

- EC8D:** PNP transistor output, 8 points, shortcircuit protection
EC16D: PNP transistor output, 16 points, shortcircuit protection

FUNCTIONS & FEATURES

The R7ML, complying with MECHATROLINK-I and -II Intelligent I/O specifications, interfaces analog and discrete I/O signals with a PLC or PC via MECHATROLINK. A 'basic' module can be attached with an 'extension' module. By combining two modules, single station can handle mixed analog and discrete signals, 32-point discrete inputs, 32-point discrete outputs, 16-point discrete I/Os and other combinations of signals. Input sensor type (thermocouple, RTD) and range can be selected with the front DIP switches for all channels. In order to set different selections for individual channels, zero/span adjustments, scaling and temperature unit, use the PC Configurator Software (model: R7CON)

RELATED PRODUCTS

- PC configurator software (model: R7CON)
Downloadable at M-System's web site.
A dedicated cable is required to connect the module to the PC. Please refer to the internet software download site or the users manual for the PC configurator for applicable cable types.

GENERAL SPECIFICATIONS

- **Common Specifications**
Power input: 24 V DC $\pm 10\%$
Insulation resistance: $\geq 100\text{ M}\Omega$ with 500 V DC
Dielectric strength:
Discrete I/O module
1500 V AC @ 1 minute (I/O to power)
500 V AC @ 1 minute (MECHATROLINK or FG to I/O or power)
Analog I/O module
1500 V AC @ 1 minute (between each I/O, I/O to power)
500 V AC @ 1 minute (MECHATROLINK or FG to I/O or power)
Operating temperature: 0 to 55°C (32 to 131°F)
Operating humidity: 30 to 90 %RH (non-condensing)
Atmosphere: No corrosive gas or heavy dust
Storage temperature: -20 to +65°C (-4 to +149°F)
Mounting: DIN rail (35 mm wide)
Connection
Communication: MECHATROLINK connectors
Power & I/O: M3 screw terminals (torque 0.5 N·m)
Screw terminal material: Nickel-plated steel
Recommended solderless terminal: Refer to the drawing at the end of the section.
Applicable wire size 0.3 to 0.75 mm²



Status indicator LED: PWR (Refer to the instruction manual for details)

■ **Current Consumption at 24 V DC; Weight**

R7ML-DA16: 70 mA; 220 g (7.7 oz)
R7ML-DC16A: 85 mA; 220 g (7.7 oz)
R7ML-DC16B: 85 mA; 220 g (7.7 oz)
R7ML-DC16D: 85 mA; 220 g (7.7 oz)
R7ML-SV4: 70 mA; 220 g (7.7 oz)
R7ML-TS4: 70 mA; 220 g (7.7 oz)
R7ML-RS4: 70 mA; 250 g (8.8 oz)
R7ML-YV2: 100 mA; 200 g (7.0 oz)
R7ML-YS2: 130 mA; 200 g (7.0 oz)
R7ML-EA8: 10 mA; 90 g (3.2 oz)
R7ML-EA16: 20 mA; 150 g (5.3 oz)
R7ML-EC8A: 10 mA; 90 g (3.2 oz)
R7ML-EC16A: 30 mA; 150 g (5.3 oz)
R7ML-EC8B: 10 mA; 90 g (3.2 oz)
R7ML-EC16B: 30 mA; 150 g (5.3 oz)
R7ML-EC8D: 10 mA; 90 g (3.2 oz)
R7ML-EC16D: 20 mA; 150 g (5.3 oz)

■ **Recommended solderless terminal (unit: mm(inch))**

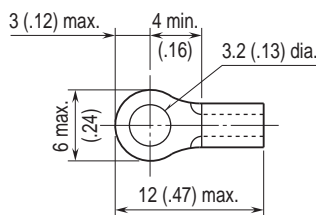

Distance between stations: 50 cm min.

Transmission media: MECHATROLINK cable (Model JEPMC-W6003-x-E, Yaskawa Controls Co., Ltd.)

Max. number of slaves: 30

(The maximum number of slaves might change depending on the master unit. Refer to the manual of the master unit)

Transmission cycle: 0.5 msec., 1 msec., 1.5 msec., 2 msec., 4 msec., 8 msec.

Data length: 17 bytes / 32 bytes selectable (Must choose identical data size for all stations on one network)

STANDARDS & APPROVALS

CE conformity:

EMC Directive (2004/108/EC)

EMI EN 61000-6-4: 2007

EMS EN 61000-6-2: 2005

(Confirm approvals availability on the model's code)

MECHATROLINK COMMUNICATION

■ **MECHATROLINK:**

Mode: MECHATROLINK-I or II (data length 17 byte) or II (32byte)

(Function selected with Rotary SW. Factory setting: MECHATROLINK-II (17byte))

Station address: 60H - 7FH

(Function selected with Rotary SW. Factory setting: 60H)

• **MECHATROLINK-I**

Baud rate: 4 Mbps

Transmission distance: 50 m max.

Distance between stations: 30 cm min.

Transmission media: MECHATROLINK cable (Model JEPMC-W6003-x-E, Yaskawa Controls Co., Ltd.)

Max. number of slaves: 15

(The maximum number of slaves might change depending on the master unit. Refer to the manual of the master unit)

Transmission cycle: 2 msec. (fixed)

Data length: 17 byte

• **MECHATROLINK-II**

Baud rate: 10 Mbps

Transmission distance: 50 m max.



EXTERNAL VIEW

■ BASIC MODULE

■ FRONT VIEW

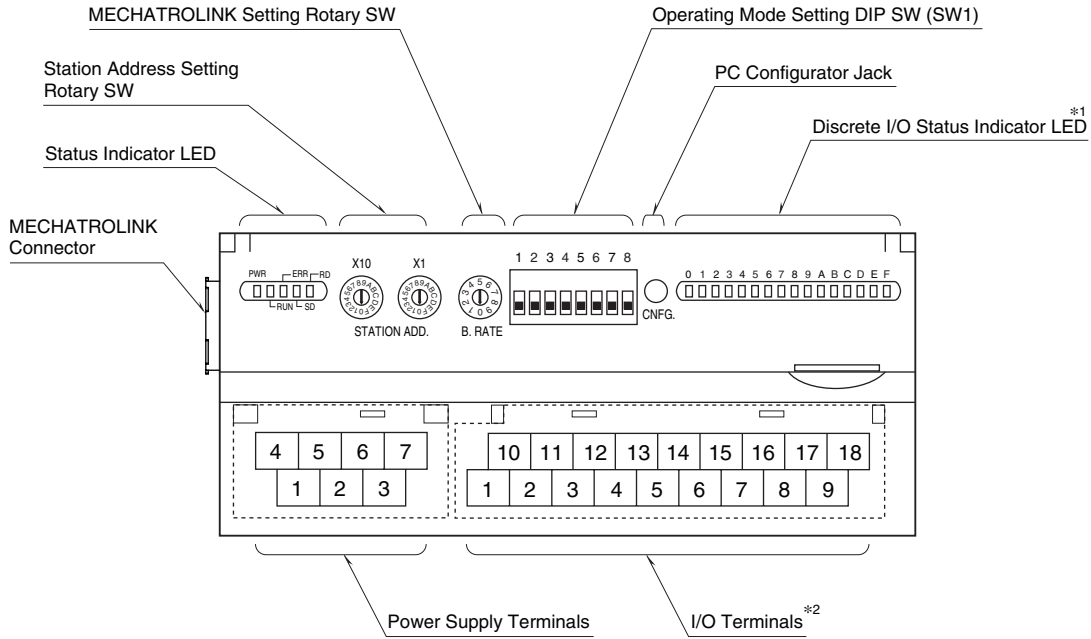

*1. Not available with analog I/O modules.
*2. 10 screw terminals for analog output modules.

■ LEFT SIDE VIEW

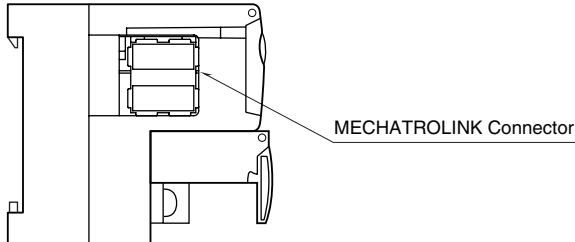

■ EXTENSION MODULE

■ DISCRETE, 8 POINTS

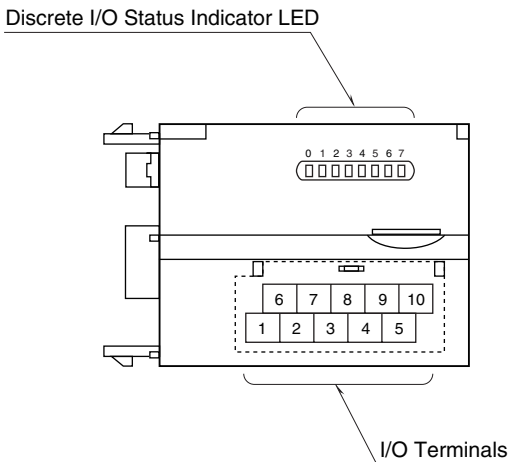

■ DISCRETE, 16 POINTS

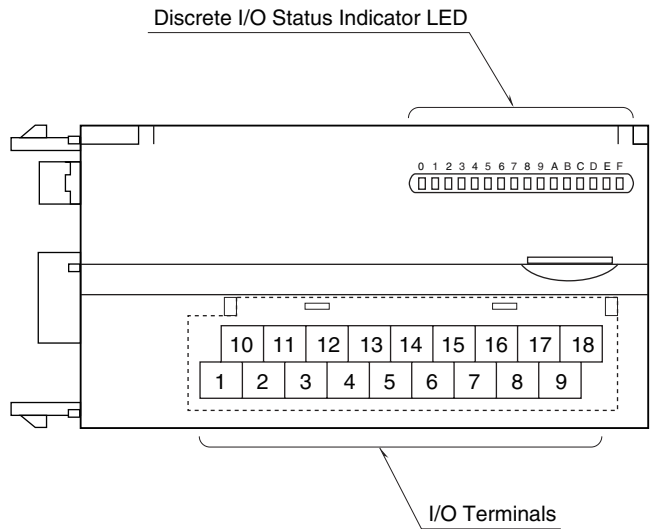

CONNECTION DIAGRAMS

■ POWER SUPPLY TERMINAL ASSIGNMENT

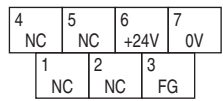

NO.	ID	FUNCTION, NOTES
1	NC	----
2	NC	----
3	FG	FG
4	NC	----
5	NC	----
6	+24V	Power input (24V DC)
7	0V	Power input (0V)

■ MECHATROLINK CONNECTION

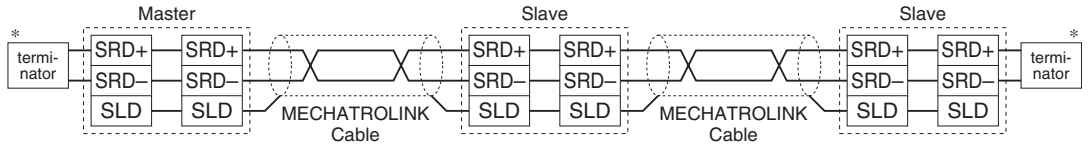

*Terminator
 Be sure to connect the terminating resistors to the unit at both ends of transmission line.
 Use the terminating resistor dedicated for MECHATROLINK: Model JEPMC-W6022, Yaskawa Controls Co., Ltd.
 Certain types of Master units may have incorporated terminating resistors. Consult the instruction manual for the Master.



MECHATROLINK RELATED COMMANDS

■ MECHATROLINK DATA LINK LAYER COMMAND DESCRIPTIONS

The R7ML, Intelligent I/O, performs the connection-type communications according to MECHATROLINK protocol. The following tables explain Data Link Layer Commands supported by the R7ML.

• MDS Command (04H) Data Format

BYTE	COMMAND	RESPONSE	REMARKS
0	MDS (04H)	S(0) (90H)	Message Data Search (MDS) Command: Read the ID from the slave station S(0): Response to MDS
1	0	ID1 (00H)	
2	0	ID2 (80H)	Intelligent I/O specified
3	0	0	
4	0	0	
5	0	0	
6	0	0	
7	0	0	
8	0	0	
9	0	0	
10	0	0	
11	0	0	
12	0	0	
13	0	0	
14	0	0	
15	0	0	
16	0	0	
17	0	0	Byte 17 through 31 are always 0 in the 32-byte mode.
:	:	:	These bytes are unavailable for MECHATROLINK-I, or MECHATROLINK-II in the 17-byte mode.
31	0	0	

• CDRW Command (03H) Data Format

BYTE	COMMAND	RESPONSE	REMARKS
0	CDRW (03H)	ACK (01H)	Cyclic Data Read/Write (CDRW) Command: Link transmission Acknowledge (ACK): Positive response to CDRW
1	CMD	RCMD	CMD: Application Layer Command RCMD: Response to Application Layer Command
2			Byte 2 through 16 depend upon the Application Layer Command type.
:			
16			
17			Byte 17 through 31 depend upon the Application Layer Command type.
:			These bytes are unavailable for MECHATROLINK-I, or MECHATROLINK-II in the 17-byte mode.
31			



■ MECHATROLINK APPLICATION LAYER COMMAND DESCRIPTIONS

The following tables explain Application Layer Commands supported by the R7ML.

• NOP Command (00H) Data Format

BYTE	COMMAND	RESPONSE	REMARKS
0	CDRW (03H)	ACK (01H)	Cyclic Data Read/Write (CDRW) Command: Link transmission Acknowledge (ACK): Positive response to CDRW
1	NOP (00H)	NOP (00H)	No Operation (NOP) Command: Nothing is performed.
2	0	ALARM	Error code: See "MECHATROLINK DATA DESCRIPTIONS"
3	0	STATUS1	Status code: See "MECHATROLINK DATA DESCRIPTIONS"
4	0	STATUS2	Status code: See "MECHATROLINK DATA DESCRIPTIONS"
5	0	0	
6	0	0	
7	0	0	
8	0	0	
9	0	0	
10	0	0	
11	0	0	
12	0	0	
13	0	0	
14	0	0	
15	0	0	
16	0	0	
17	0	0	Byte 17 through 31 are always 0 in the 32-byte mode.
:	:	:	These bytes are unavailable for MECHATROLINK-I, or MECHATROLINK-II in the 17-byte mode.
31	0	0	

• ID_RD Command (03H) Ddata Format

BYTE	COMMAND	RESPONSE	REMARKS
0	CDRW (03H)	ACK (01H)	Cyclic Data Read/Write (CDRW) Command: Link transmission Acknowledge (ACK): Positive response to CDRW
1	ID_RD (03H)	ID_RD (03H)	Read ID (ID_RD) Command: Read out the device ID
2	0	ALARM	Error code: See "MECHATROLINK DATA DESCRIPTIONS"
3	0	STATUS1	Status code: See "MECHATROLINK DATA DESCRIPTIONS"
4	0	STATUS2	Status code: See "MECHATROLINK DATA DESCRIPTIONS"
5	DEVICE_CODE	DEVICE_CODE	Specifies the device code 00H: Product's model number 0FH: Vendor code
6	OFFSET	OFFSET	Indicates where to start reading in the specified device ID
7	SIZE	SIZE	Number of byte counts to read
8	0	ID1	ASCII or binary data
9	0	ID2	ASCII or binary data
10	0	ID3	ASCII or binary data
11	0	ID4	ASCII or binary data
12	0	ID5	ASCII or binary data
13	0	ID6	ASCII or binary data
14	0	ID7	ASCII or binary data
15	0	ID8	ASCII or binary data
16	0	0	
17	0	0	Byte 17 through 31 are always 0 in the 32-byte mode.
:	:	:	These bytes are unavailable for MECHATROLINK-I, or MECHATROLINK-II in the 17-byte mode.
31	0	0	



• CONNECT Command (0EH) Data Format

BYTE	COMMAND	RESPONSE	REMARKS
0	CDRW (03H)	ACK (01H)	Cyclic Data Read/Write (CDRW) Command: Link transmission Acknowledge (ACK): Positive response to CDRW
1	CONNECT (0EH)	CONNECT (0EH)	Establish Connection (CONNECT) Command: Requests to establish connection to MECHATROLINK
2	0	ALARM	Error code: See "MECHATROLINK DATA DESCRIPTIONS"
3	0	STATUS1	Status code: See "MECHATROLINK DATA DESCRIPTIONS"
4	0	STATUS2	Status code: See "MECHATROLINK DATA DESCRIPTIONS"
5	VER	VER	Application Layer version number 10H: MECHATROLINK-I 21H: MECHATROLINK-II
6	COM_MODE	COM_MODE	Communication mode 00H: 17-byte mode 80H: 32-byte mode
7	COM_TIME	COM_TIME	Communication cycle (milliseconds) MECHATROLINK-I: Multiples of two (2) MECHATROLINK-II: Integral multiples of the transmission cycle
8	0	0	
9	0	0	
10	0	0	
11	0	0	
12	0	0	
13	0	0	
14	0	0	
15	0	0	
16	0	0	
17	0	0	Byte 17 through 31 are always 0 in the 32-byte mode.
:	:	:	These bytes are unavailable for MECHATROLINK-I, or MECHATROLINK-II in the 17-byte mode.
31	0	0	

• DISCONNECT Command (0FH) Data Format

BYTE	COMMAND	RESPONSE	REMARKS
0	CDRW (03H)	ACK (01H)	Cyclic Data Read/Write (CDRW) Command: Link transmission Acknowledge (ACK): Positive response to CDRW
1	DISCONNECT (0FH)	DISCONNECT (0FH)	Release Connection (DISCONNECT) Command: Requests to release connection to MECHATROLINK
2	0	ALARM	Error code: See "MECHATROLINK DATA DESCRIPTIONS"
3	0	STATUS1	Status code: See "MECHATROLINK DATA DESCRIPTIONS"
4	0	STATUS2	Status code: See "MECHATROLINK DATA DESCRIPTIONS"
5	0	0	
6	0	0	
7	0	0	
8	0	0	
9	0	0	
10	0	0	
11	0	0	
12	0	0	
13	0	0	
14	0	0	
15	0	0	
16	0	0	
17	0	0	Byte 17 through 31 are always 0 in the 32-byte mode.
:	:	:	These bytes are unavailable for MECHATROLINK-I, or MECHATROLINK-II in the 17-byte mode.
31	0	0	



• **DATA_RWA Command (50H) Data Format**

BYTE	COMMAND	RESPONSE	REMARKS
0	CDRW (03H)	ACK (01H)	Cyclic Data Read/Write (CDRW) Command: Link transmission Acknowledge (ACK): Positive response to CDRW
1	DATA_RWA (50H)	DATA_RWA (50H)	Data Read/Write_A (DATA_RWA) Command: Refreshes I/O data
2	0	ALARM	Error code: See "MECHATROLINK DATA DESCRIPTIONS"
3	0	STATUS1	Status code: See "MECHATROLINK DATA DESCRIPTIONS"
4	0	STATUS2	Status code: See "MECHATROLINK DATA DESCRIPTIONS"
5	CH1 OUT LO	CH1 IN LO	CHx OUT: Output data: See "MECHATROLINK DATA DESCRIPTIONS" CHx IN: Input data: See "MECHATROLINK DATA DESCRIPTIONS"
6	CH1 OUT HI	CH1 IN HI	
7	CH2 OUT LO	CH2 IN LO	
8	CH2 OUT HI	CH2 IN HI	
9	CH3 OUT LO	CH3 IN LO	
10	CH3 OUT HI	CH3 IN HI	
11	CH4 OUT LO	CH4 IN LO	
12	CH4 OUT HI	CH4 IN HI	
13	EXT OUT LO	EXT IN LO	EXT OUT: Extension output data: See "MECHATROLINK DATA DESCRIPTIONS"
14	EXT OUT HI	EXT IN HI	EXT IN: Extension input data: See "MECHATROLINK DATA DESCRIPTIONS"
15	0	STATUS LO	R7ML status: See "MECHATROLINK DATA DESCRIPTIONS"
16	0	STATUS HI	
17	0	0	Byte 17 through 31 are always 0 in the 32-byte mode. These bytes are unavailable for MECHATROLINK-I, or MECHATROLINK-II in the 17-byte mode.
:	:	:	
31	0	0	
:	:	:	



■ MECHATROLINK APPLICATION LAYER DATA DESCRIPTIONS

• Alarm Error Codes

Errors detected at the slave are set at ALARM in the response and sent to the master.

ERROR CODE	DESCRIPTION	CLASSIFICATION
00H	Normal status	----
01H	Invalid Command: Command is not supported.	Warning
02H	Command Not Allowed: Command execution conditions are not met.	Warning
03H	Invalid Data: Data in the command is not correct.	Warning
04H	Synchronization Error	Alarm

• STATUS1 Bit Allocations

Alarm/Warning classification and status information are set at STATUS1 in the response and sent to the master.

BIT	DEFINITION	DESCRIPTION
0	Alarm Bit	0 : Normal, 1 : Alarm
1	Warning Bit	0 : Normal, 1 : Warning
2	Command Ready Bit	0 : Command cannot be accepted (busy), 1 : Command can be accepted (ready)
3...7	Unused	----

• STATUS2

Reserved for future use

• Input Data

Input data to be sent from the slave to the master are set in the response. With an output module, output data in the command are repeated and sent back to the master.

ID	DESCRIPTION	REMARKS
CH1 IN LO	CH1 data, low 8 bits	R7ML-DA16: Bit 0 through 7 data are set. R7ML-DC16x, R7ML-YS2, R7ML-YV2: Output data are repeated.
CH1 IN HI	CH1 data, high 8 bits	R7ML-DA16: Bit 8 through 15 data are set. R7ML-DC16x, R7ML-YS2, R7ML-YV2: Output data are repeated.
CH2 IN LO	CH2 data, low 8 bits	R7ML-DA16, R7ML-DC16x: Unused R7ML-YS2, R7ML-YV2: Output data are repeated.
CH2 IN HI	CH2 data, high 8 bits	R7ML-DA16, R7ML-DC16x: Unused R7ML-YS2, R7ML-YV2: Output data are repeated.
CH3 IN LO	CH3 data, low 8 bits	R7ML-DA16, R7ML-DC16x, R7ML-YS2, R7ML-YV2 : Unused
CH3 IN HI	CH3 data, high 8 bits	R7ML-DA16, R7ML-DC16x, R7ML-YS2, R7ML-YV2 : Unused
CH4 IN LO	CH4 data, low 8 bits	R7ML-DA16, R7ML-DC16x, R7ML-YS2, R7ML-YV2 : Unused
CH4 IN HI	CH4 data, high 8 bits	R7ML-DA16, R7ML-DC16x, R7ML-YS2, R7ML-YV2 : Unused

• Output Data

Output data to be sent from the master to the slave are set in the command. Unused with all input modules.

ID	DESCRIPTION	REMARKS
CH1 OUT LO	CH1 data, low 8 bits	R7ML-DC16x: Bit 0 through 7 data are set.
CH1 OUT HI	CH1 data, high 8 bits	R7ML-DC16x: Bit 8 through 15 data are set.
CH2 OUT LO	CH2 data, low 8 bits	R7ML-DC16x: Unused
CH2 OUT HI	CH2 data, high 8 bits	R7ML-DC16x: Unused
CH3 OUT LO	CH3 data, low 8 bits	R7ML-DC16x, R7ML-YS2, R7ML-YV2 : Unused
CH3 OUT HI	CH3 data, high 8 bits	R7ML-DC16x, R7ML-YS2, R7ML-YV2 : Unused
CH4 OUT LO	CH4 data, low 8 bits	R7ML-DC16x, R7ML-YS2, R7ML-YV2 : Unused
CH4 OUT HI	CH4 data, high 8 bits	R7ML-DC16x, R7ML-YS2, R7ML-YV2 : Unused

• Extension Input Data

Input data of the extension module to be sent from the slave to the master are set in the response. With an output extension module, output data in the command are repeated and sent back to the master.

ID	DESCRIPTION	REMARKS
EXT IN LO	Extension data, low 8 bits	R7ML-EA16, R7ML-EA8: Bit 0 through 7 data are set. R7ML-EC16x, R7ML-EC8x: Output data are repeated.
EXT IN HI	Extension data, high 8 bits	R7ML-EA16: Bit 8 through 15 data are set. R7ML-EC16x: Output data are repeated. R7ML-EA8, R7ML-EC8x: Unused



• Extension Output Data

Output data to be sent from the master to the slave are set in the command. Unused with all input modules.

ID	DESCRIPTION	REMARKS
EXT OUT LO	Extension data, low 8 bits	R7ML-EC16x: Bit 0 through 7 data are set. R7ML-EC8x: Bit 0 through 7 data are set.
EXT OUT HI	Extension data, high 8 bits	R7ML-EC16x: Bit 8 through 15 data are set. R7ML-EC8x: Unused

• R7ML Status Data

Status data to be sent from the slave to the master are set in the response. Refer to "I/O DATA DESCRIPTIONS."

DATA CONVERSION

■ 0 – 100% DATA CONVERSION

Analog input data is converted into digital representations of 0 – 100% proportional to each scaled range. The converted % values are multiplied by 100 and expressed in 16 bits.

Overrange input is possible from -15 to +115% of the nominal range. When the signal exceeds the limit, the data is fixed at -15% or +115% respectively.

• Input Range 0 – 5V DC

Input Value	Input %	Converted Data, Decimal	Converted Data, Hex
≤ -0.75V	-15%	-1500	FA24
0V	0%	0	0
5V	100%	10000	2710
≥ 5.75V	115%	11500	2CEC

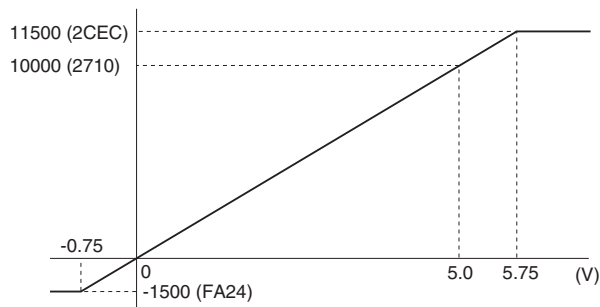

Analog output is converted in the reverse order of the input data. The output range 0 – 5V DC is expressed as 10000 at 5.0V (100%) and 0 at 0V (0%).



■ TEMPERATURE DATA CONVERSION

Temperature data (thermocouple and RTD) are represented in engineering unit value, °C or K, multiplied by 10 and expressed in 16 bits. °F data is represented in engineering unit value, without multiplication.

•Input Type K Thermocouple

Input Value	Converted Data, Decimal	Converted Data, Hex
≤ -272°C	-2720	F560
-150°C	-1500	FA24
1370°C	13700	3584
≥ 1472°C	14720	3980

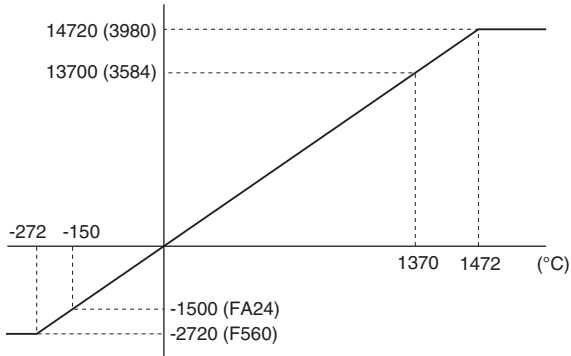

I/O DATA DESCRIPTIONS

■ DISCRETE I/O

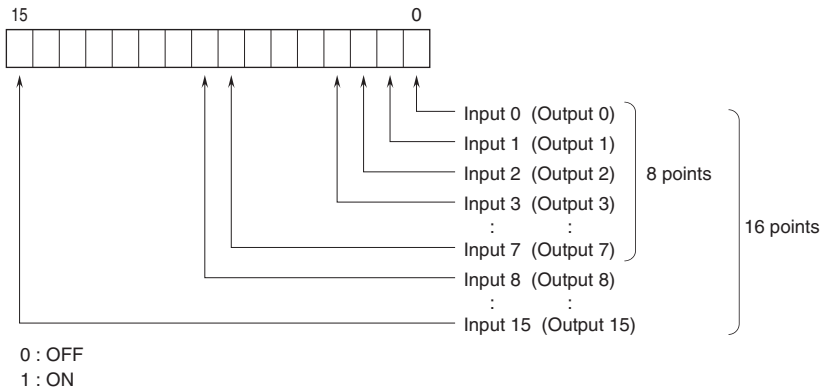

■ ANALOG I/O

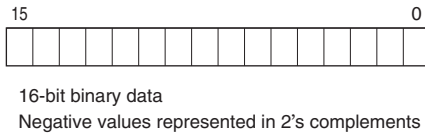

■ STATUS

Analog input modules (models: R7ML-SV4, R7ML-TS4, R7ML-RS4) can show input status of each channel.

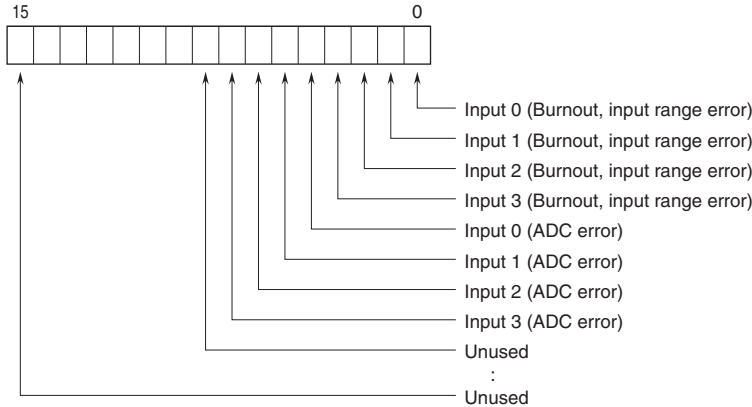

Burnout, input range error ($\leq -15\%$, $\geq +115\%$)
 0 : Normal 1 : Error
 ADC error (no response from ADC)
 0 : Normal 1 : Error

EXTENSION MODULE

A 'basic' module can be attached with one 'extension' module. The extension module is powered from the basic module. By combining two modules, single station can handle mixed analog and discrete signals, 32-point discrete inputs, 32-point discrete outputs, 16-point discrete I/Os and other combinations of signals.

■ OUTPUT AT THE LOSS OF COMMUNICATION

The extension module is set to 'Hold Output' by factory default setting. The PC Configurator is used to change the setting to 'Reset Output.'

■ CONNECTING THE EXTENSION MODULE

- 1) Remove the extension connector cover located at the side of the basic module.
- 2) Connect the extension module.

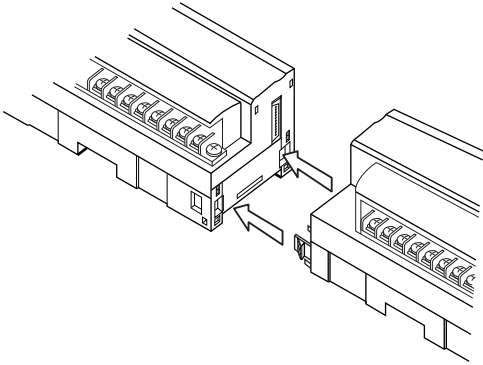

- 3) Mount the combined module on a DIN rail.



MODEL: R7ML

DIMENSIONS unit: mm (inch)

■ BASIC MODULE

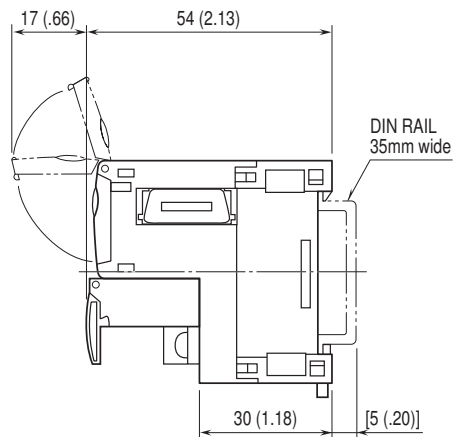
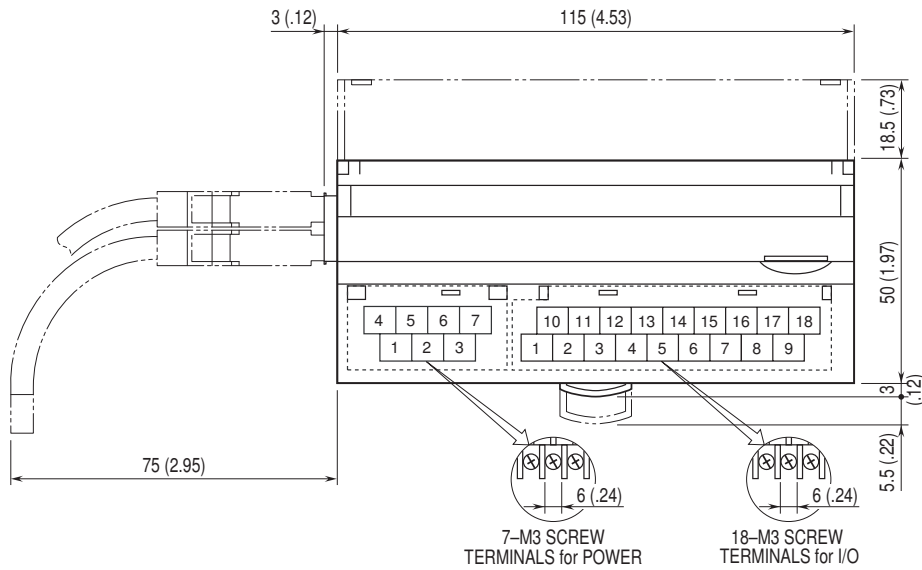

• R7ML-TS4

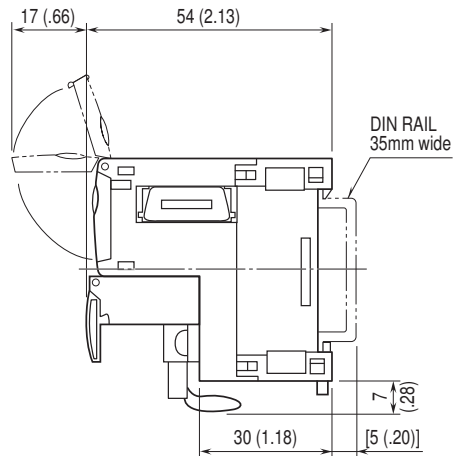

■ ANALOG OUTPUT

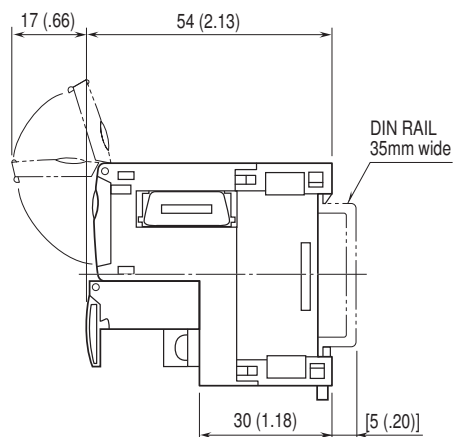
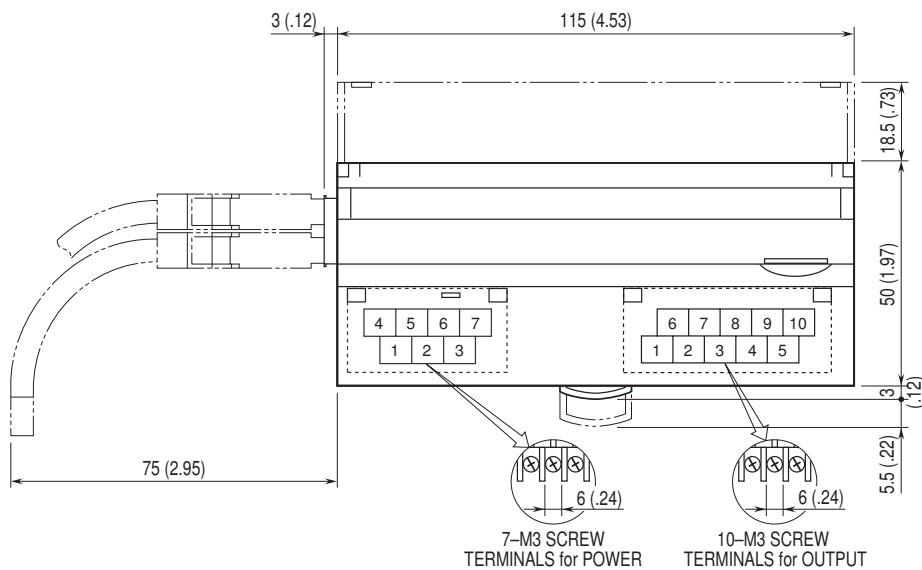

■ EXTENSION MODULE, 8 POINTS

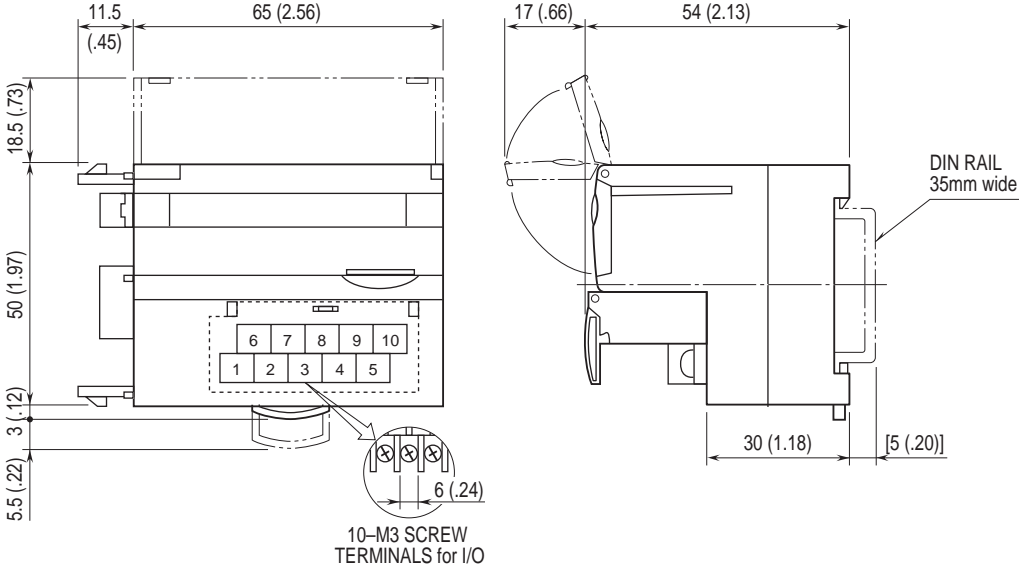

■ EXTENSION MODULE, 16 POINTS

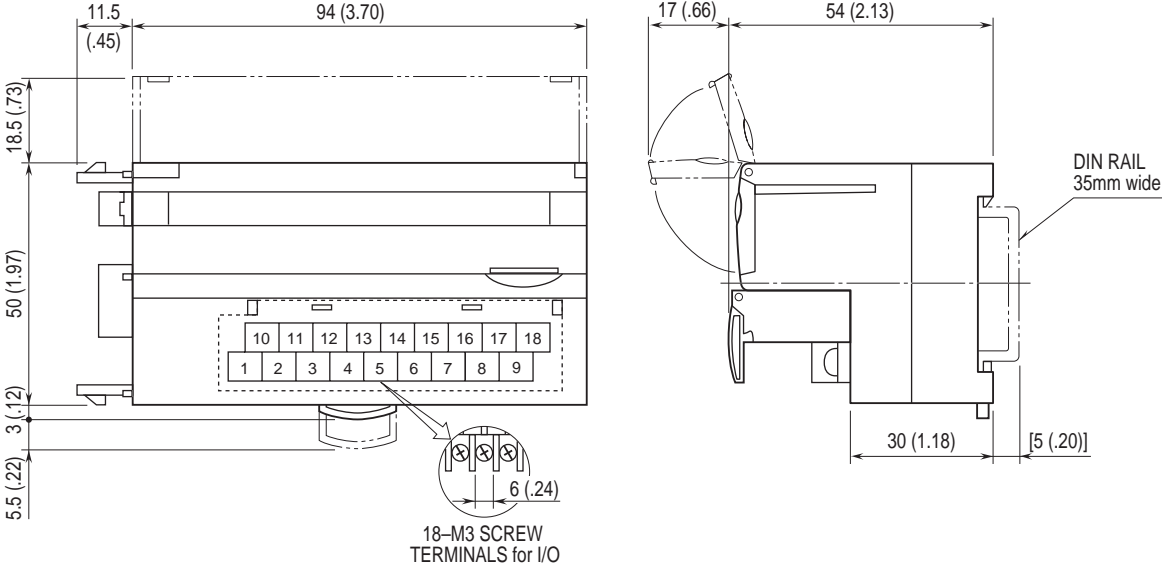

DISCRETE INPUT MODULE, 16 points

MODEL: R7ML-DA16

SPECIFICATIONS

Common: Positive or negative common (NPN/PNP) per 16 points

Number of I/O: Input, 16 points

Maximum inputs applicable at once: No limit (at 24 V DC)

I/O status indicator: LED turns on with closed contact.

Isolation: Input to MECHATROLINK or FG to power input

Rated input voltage: 24 V DC $\pm 10\%$; ripple 5 %p-p max.

ON voltage / current: ≥ 15 V DC (input - COM) / ≥ 3.5 mA

OFF voltage / current: ≤ 5 V DC (input - COM) / ≤ 1 mA

Input current: ≤ 5.5 mA per point at 24 V DC

Input resistance: Approx. 4.4 k Ω

ON delay: ≤ 2.0 msec.

OFF delay: ≤ 2.0 msec.

OPERATING MODE SETTING

(*) Factory setting

Caution ! - SW1-3, 1-4, 1-5 are unused.

Be sure to turn off unused ones.

• Extension (SW1-1, 1-2)

SW1-1	SW1-2	EXTENSION
OFF	OFF	No extension (*)
ON	OFF	Discrete input, 8 or 16 points
OFF	ON	Discrete output, 8 or 16 points

• Read rate (SW1-6, 1-7, 1-8)

SW1-6	SW1-7	SW1-8	Read rate
OFF	OFF	OFF	≤ 10 msec. (*)
ON	OFF	OFF	≤ 1 msec.
OFF	ON	OFF	≤ 5 msec.
ON	ON	OFF	≤ 20 msec.
OFF	OFF	ON	≤ 50 msec.
ON	OFF	ON	≤ 70 msec.
OFF	ON	ON	≤ 100 msec.
ON	ON	ON	≤ 200 msec.

TERMINAL ASSIGNMENTS

10	11	12	13	14	15	16	17	18
NC	X1	X3	X5	X7	X9	XB	XD	XF
1	2	3	4	5	6	7	8	9
COM	X0	X2	X4	X6	X8	XA	XC	XE

NO.	ID	FUNCTION	NO.	ID	FUNCTION
1	COM	Common	10	NC	No Connection
2	X0	Input 0	11	X1	Input 1
3	X2	Input 2	12	X3	Input 3
4	X4	Input 4	13	X5	Input 5
5	X6	Input 6	14	X7	Input 7
6	X8	Input 8	15	X9	Input 9
7	XA	Input 10	16	XB	Input 11
8	XC	Input 12	17	XD	Input 13
9	XE	Input 14	18	XF	Input 15

CIRCUIT DIAGRAM

Note: In order to improve EMC performance, bond the FG terminal to ground.

Caution: FG terminal is NOT a protective conductor terminal.



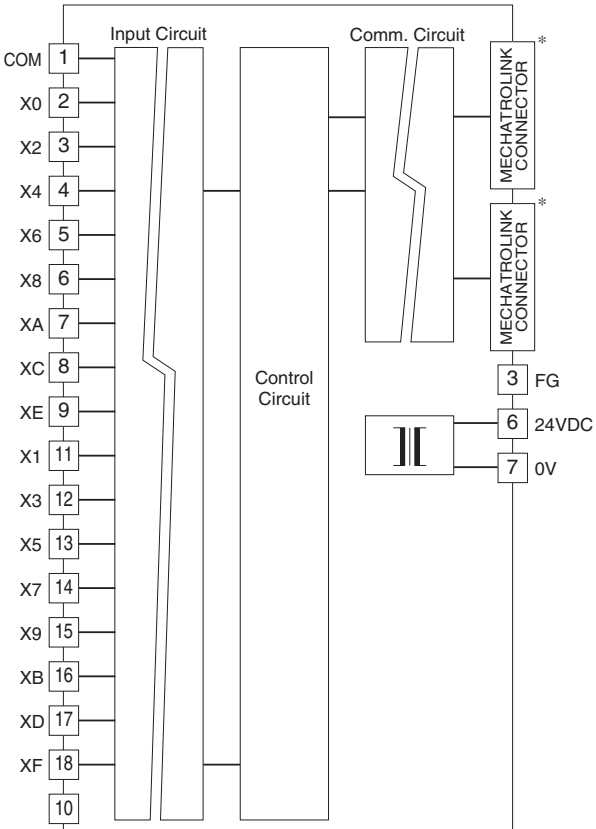

*MECHATROLINK connectors are internally connected.
The network cable can be connected to either one.

■ Input Circuit

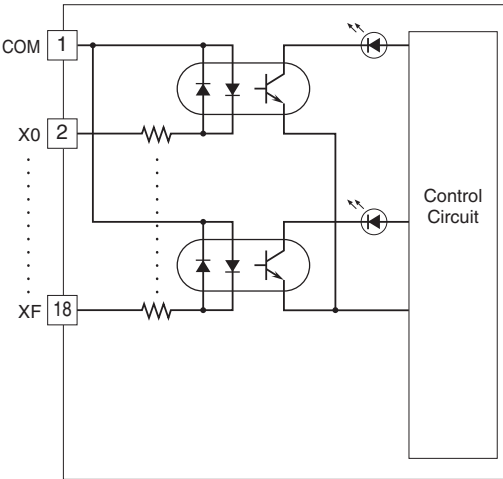

■ Input Connection Examples

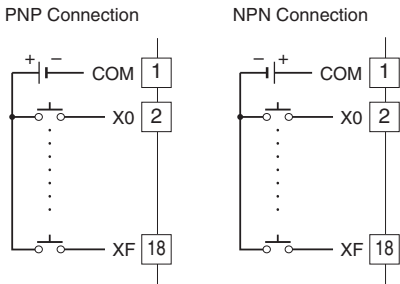

MODEL: R7ML

NPN TRANSISTOR OUTPUT MODULE, 16 points

MODEL: R7ML-DC16A

SPECIFICATIONS

Common: Negative common (NPN) per 16 points
Number of I/O: Output, 16 points
Maximum outputs applicable at once: No limit (at 24 V DC)
I/O status indicator: LED turns on with closed contact.
Isolation: Output to MECHATROLINK or FG to power input
Rated load voltage: 24 V DC $\pm 10\%$
Rated output current: 0.25 A per point, 2.0 A per common
Residual voltage: ≤ 1.2 V
Leakage current: ≤ 0.1 mA
ON delay: ≤ 0.5 msec.
OFF delay: ≤ 1.5 msec.

OPERATING MODE SETTING

(*) Factory setting

Caution ! - SW1-3, 1-5 through 1-8 are unused. Be sure to turn off unused ones.

• Output at the loss of communication (SW1-4)

SW1-4	OUTPUT AT THE LOSS OF COMMUNICATION	
OFF	Reset the output (turned off)	
ON	Hold the output (*) (maintains the last data received normally)	

• Extension (SW1-1, 1-2)

SW1-1	SW1-2	EXTENSION
OFF	OFF	No extension (*)
ON	OFF	Discrete input, 8 or 16 points
OFF	ON	Discrete output, 8 or 16 points

TERMINAL ASSIGNMENTS

10	11	12	13	14	15	16	17	18
+24 V	Y1	Y3	Y5	Y7	Y9	YB	YD	YF
1	2	3	4	5	6	7	8	9
0 V	Y0	Y2	Y4	Y6	Y8	YA	YC	YE

NO.	ID	FUNCTION	NO.	ID	FUNCTION
1	0 V	0 V (common)	10	+24 V	24 V DC
2	Y0	Output 0	11	Y1	Output 1
3	Y2	Output 2	12	Y3	Output 3
4	Y4	Output 4	13	Y5	Output 5
5	Y6	Output 6	14	Y7	Output 7
6	Y8	Output 8	15	Y9	Output 9
7	YA	Output 10	16	YB	Output 11
8	YC	Output 12	17	YD	Output 13
9	YE	Output 14	18	YF	Output 15

CIRCUIT DIAGRAM

Note: In order to improve EMC performance, bond the FG terminal to ground.

Caution: FG terminal is NOT a protective conductor terminal.

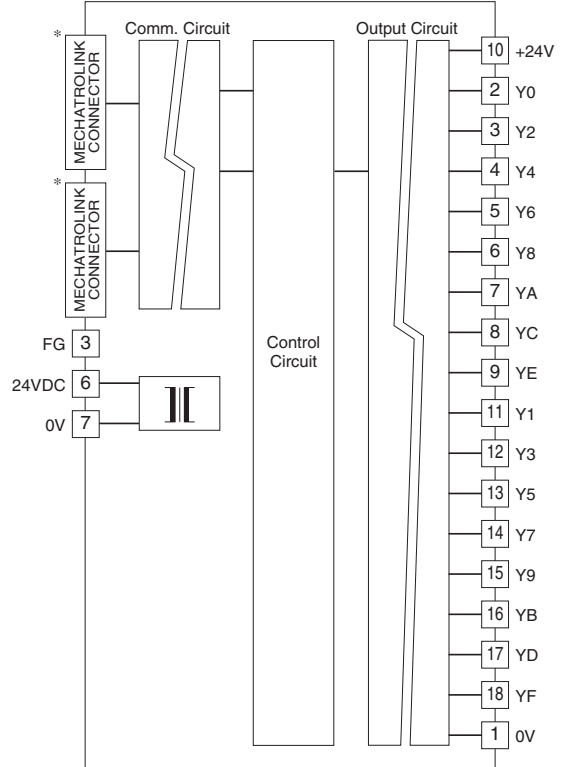

*MECHATROLINK connectors are internally connected. The network cable can be connected to either one.

■ Output Circuit

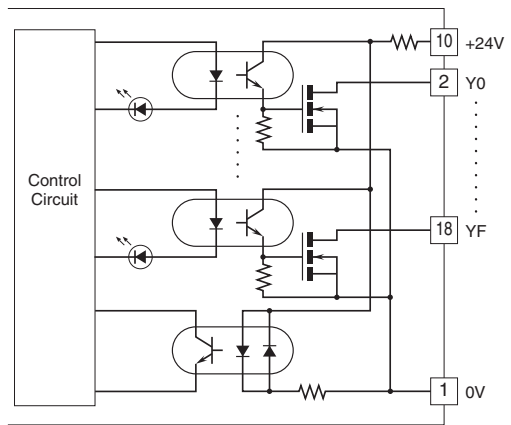

■ Output Connection Example

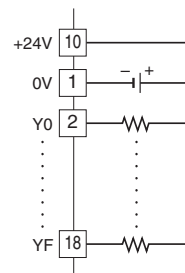

PNP TRANSISTOR OUTPUT MODULE, 16 points

MODEL: R7ML-DC16B

SPECIFICATIONS

- Common:** Positive common (PNP) per 16 points
- Number of I/O:** Output, 16 points
- Maximum outputs applicable at once:** No limit (at 24 V DC)
- I/O status indicator:** LED turns on with closed contact.
- Isolation:** Output to MECHATROLINK or FG to power input
- Rated load voltage:** 24 V DC $\pm 10\%$
- Rated output current:** 0.25 A per point, 2.0 A per common
- Residual voltage:** ≤ 1.2 V
- Leakage current:** ≤ 0.1 mA
- ON delay:** ≤ 0.5 msec.
- OFF delay:** ≤ 1.5 msec.

OPERATING MODE SETTING

(*) Factory setting

Caution ! - SW1-3, 1-5 through 1-8 are unused. Be sure to turn off unused ones.

• Output at the loss of communication (SW1-4)

SW1-4	OUTPUT AT THE LOSS OF COMMUNICATION	
OFF	Reset the output (turned off)	
ON	Hold the output (*) (maintains the last data received normally)	

• Extension (SW1-1, 1-2)

SW1-1	SW1-2	EXTENSION
OFF	OFF	No extension (*)
ON	OFF	Discrete input, 8 or 16 points
OFF	ON	Discrete output, 8 or 16 points

TERMINAL ASSIGNMENTS

10	11	12	13	14	15	16	17	18
+24 V	Y1	Y3	Y5	Y7	Y9	YB	YD	YF
1	2	3	4	5	6	7	8	9
0 V	Y0	Y2	Y4	Y6	Y8	YA	YC	YE

NO.	ID	FUNCTION	NO.	ID	FUNCTION
1	0 V	0 V	10	+24 V	24 V DC (common)
2	Y0	Output 0	11	Y1	Output 1
3	Y2	Output 2	12	Y3	Output 3
4	Y4	Output 4	13	Y5	Output 5
5	Y6	Output 6	14	Y7	Output 7
6	Y8	Output 8	15	Y9	Output 9
7	YA	Output 10	16	YB	Output 11
8	YC	Output 12	17	YD	Output 13
9	YE	Output 14	18	YF	Output 15

CIRCUIT DIAGRAM

Note: In order to improve EMC performance, bond the FG terminal to ground.

Caution: FG terminal is NOT a protective conductor terminal.

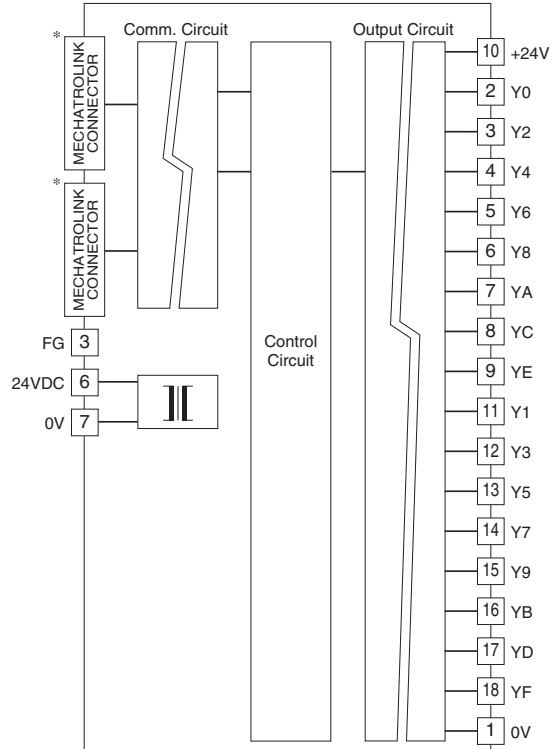

*MECHATROLINK connectors are internally connected. The network cable can be connected to either one.

■ Output Circuit

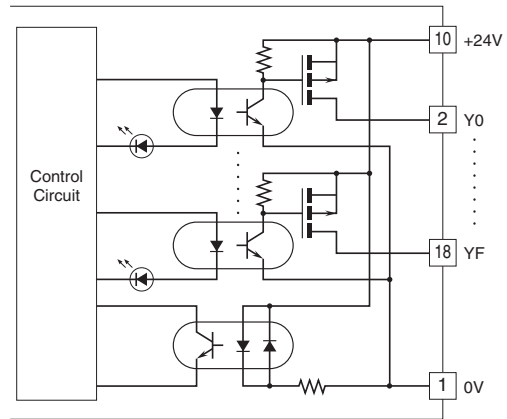

■ Output Connection Example

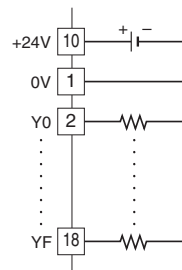

MODEL: R7ML

PNP TRANSISTOR OUTPUT MODULE, 16 points (shortcircuit protection)

MODEL: R7ML-DC16D

SPECIFICATIONS

Common: Positive common (PNP) per 16 points
Number of I/O: Output, 16 points
Maximum outputs applicable at once: No limit (at 24 V DC)
I/O status indicator: LED turns on with closed contact.
Isolation: Output to MECHATROLINK or FG to power input
Rated load voltage
Nominal: 19.2 to 30 V DC
Absolute: 15 to 45 V DC
Rated output current: 0.25 A per point, 2.0 A per common
Residual voltage: ≤ 2.0 V
Leakage current: ≤ 0.3 mA (24 V DC load, all points OFF)
ON delay: ≤ 0.5 msec.
OFF delay: ≤ 1.5 msec.
Shortcircuit protection: Works for 0.7 A or more;
 automatically resets after recovery

OPERATING MODE SETTING

(*) Factory setting

Caution ! - SW1-3, 1-5 through 1-8 are unused. Be sure to turn off unused ones.

• Output at the loss of communication (SW1-4)

SW1-4	OUTPUT AT THE LOSS OF COMMUNICATION	
OFF	Reset the output (turned off)	
ON	Hold the output (*) (maintains the last data received normally)	

• Extension (SW1-1, 1-2)

SW1-1	SW1-2	EXTENSION
OFF	OFF	No extension (*)
ON	OFF	Discrete input, 8 or 16 points
OFF	ON	Discrete output, 8 or 16 points

TERMINAL ASSIGNMENTS

10	11	12	13	14	15	16	17	18
+24V	Y1	Y3	Y5	Y7	Y9	YB	YD	YF
1	2	3	4	5	6	7	8	9
0V	Y0	Y2	Y4	Y6	Y8	YA	YC	YE

NO.	ID	FUNCTION	NO.	ID	FUNCTION
1	0 V	0 V	10	+24 V	24 V DC (common)
2	Y0	Output 0	11	Y1	Output 1
3	Y2	Output 2	12	Y3	Output 3
4	Y4	Output 4	13	Y5	Output 5
5	Y6	Output 6	14	Y7	Output 7
6	Y8	Output 8	15	Y9	Output 9
7	YA	Output 10	16	YB	Output 11
8	YC	Output 12	17	YD	Output 13
9	YE	Output 14	18	YF	Output 15

CIRCUIT DIAGRAM

Note: In order to improve EMC performance, bond the FG terminal to ground.

Caution: FG terminal is NOT a protective conductor terminal.

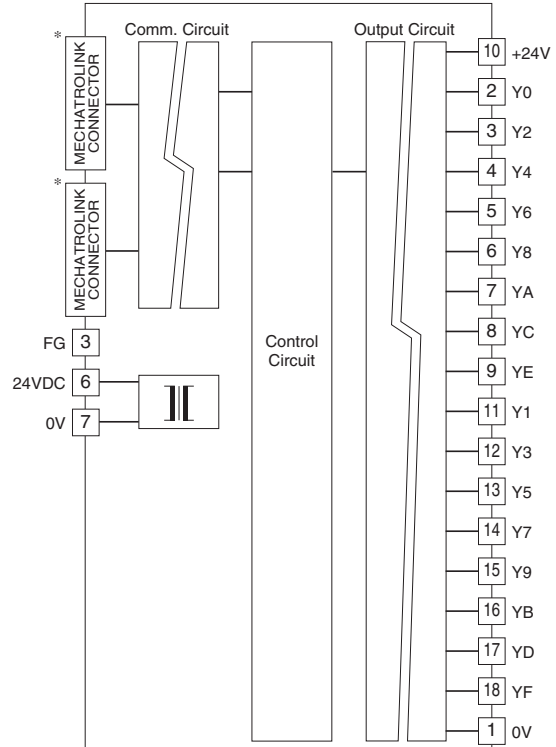

*MECHATROLINK connectors are internally connected. The network cable can be connected to either one.

■ Output Circuit

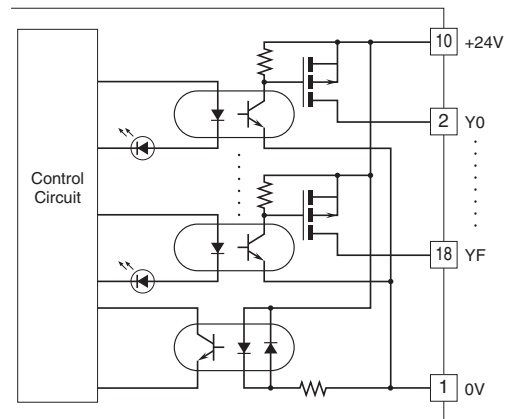

■ Output Connection Example

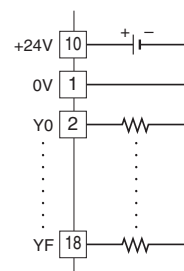

幸託有限公司
XIN TOP CORPORATION

TEL : (02)2598-1199
FAX : (02)2596-2331

E-mail : info@xintop.com
Website : www.xintop.com

DC VOLTAGE/CURRENT INPUT MODULE, 4 points

MODEL: R7ML-SV4

SPECIFICATIONS

Isolation: Input 0 to input 1 to input 2 to input 3 to MECHATROLINK or FG to power input

Converted data range: 0 - 10000 of the input range

• **Input range**

Wide span voltage: -10 - +10 V DC, -5 - +5 V DC, 0 - 10 V DC, 0 - 5 V DC, 1 - 5 V DC

Narrow span voltage: -1 - +1 V DC, 0 - 1 V DC, -0.5 - +0.5 V DC

Current range: -20 - +20 mA DC, 0 - 20 mA DC, 4 - 20 mA DC

• **Input resistance**

Wide span voltage: $\geq 1\text{ M}\Omega$

Narrow span voltage: $\geq 100\text{ k}\Omega$

Current range: $70\ \Omega$

Conversion rate / conversion accuracy:

10 msec./ $\pm 0.8\%$, 20 msec./ $\pm 0.4\%$, 40 msec./ $\pm 0.2\%$, 80 msec./ $\pm 0.1\%$

Response time: Conversion rate $\times 2 + 50$ msec. (0 - 90 %)

Temperature coefficient: $\pm 0.015\%/^{\circ}\text{C}$ ($\pm 0.008\%/^{\circ}\text{F}$)

OPERATING MODE SETTING

(*) Factory setting

• **Input range (SW1-5, 1-6, 1-7, 1-8)**

SW1-5	SW1-6	SW1-7	SW1-8	INPUT RANGE
OFF	OFF	OFF	OFF	-10 - +10 V DC (*)
ON	OFF	OFF	OFF	-5 - +5 V DC
OFF	ON	OFF	OFF	-1 - +1 V DC
ON	ON	OFF	OFF	0 - 10 V DC
OFF	OFF	ON	OFF	0 - 5 V DC
ON	OFF	ON	OFF	1 - 5 V DC
OFF	ON	ON	OFF	0 - 1V DC
ON	ON	ON	OFF	-0.5 - +0.5 V DC
ON	OFF	OFF	ON	-20 - +20 mA DC
OFF	ON	OFF	ON	4 - 20 mA DC
ON	ON	OFF	ON	0 - 20 mA DC
ON	ON	ON	ON	PC Configurator setting

• **Conversion rate / Accuracy (SW1-3, 1-4)**

SW1-3	SW1-4	CONVERSION RATE / ACCURACY
OFF	OFF	80 msec. / $\pm 0.1\%$ (*)
ON	OFF	40 msec. / $\pm 0.2\%$
OFF	ON	20 msec. / $\pm 0.4\%$
ON	ON	10 msec. / $\pm 0.8\%$

• **Extension (SW1-1, 1-2)**

SW1-1	SW1-2	EXTENSION
OFF	OFF	No extension (*)
ON	OFF	Discrete input, 8 or 16 points
OFF	ON	Discrete output, 8 or 16 points

TERMINAL ASSIGNMENTS

10	11	12	13	14	15	16	17	18
VL0	I0	VL1	I1	NC	VL2	I2	VL3	I3
1	2	3	4	5	6	7	8	9
VH0	COM0	VH1	COM1	NC	VH2	COM2	VH3	COM3

NO.	ID	FUNCTION	NO.	ID	FUNCTION
1	VH0	Wide span volt. 0	10	VL0	Narrow span volt. 0
2	COM0	Common 0	11	I0	Current range 0
3	VH1	Wide span volt. 1	12	VL1	Narrow span volt. 1
4	COM1	Common 1	13	I1	Current range 1
5	NC	No connection	14	NC	No connection
6	VH2	Wide span volt. 2	15	VL2	Narrow span volt. 2
7	COM2	Common 2	16	I2	Current range 2
8	VH3	Wide span volt. 3	17	VL3	Narrow span volt. 3
9	COM3	Common 3	18	I3	Current range 3

CIRCUIT DIAGRAM

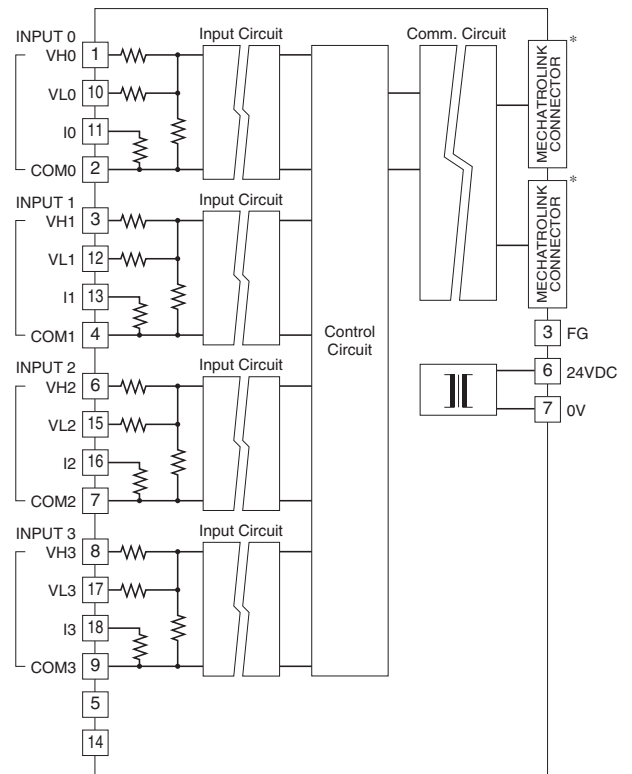

*MECHATROLINK connectors are internally connected. The network cable can be connected to either one.

■ **Input Connection Examples**

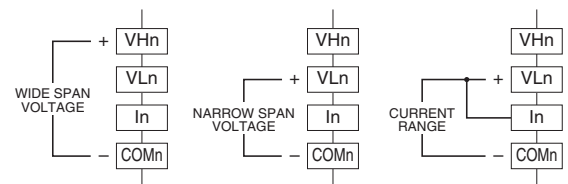

Be sure to close across VLn and In terminals for a current input.



THERMOCOUPLE INPUT MODULE, 4 points

MODEL: R7ML-TS4

SPECIFICATIONS

Isolation: Input 0 to input 1 to input 2 to input 3 to MECHATROLINK or FG to power input

Converted data range: Engineering unit value (°C, K) × 10 (integer); No multiplication for °F

Thermocouple: K, E, J, T, B, R, S, C, N, U, L, P, PR

Input resistance: ≥ 30 kΩ

Burnout sensing: ≤ 0.1 μA

Conversion accuracy: ±1°C (±1.8°F);

±2.0°C (±3.6°F) for B, R, S, C, PR

Conversion rate: 250 msec. or 1 sec.

Response time: Conversion rate × 2 + 50 msec. (0 - 90 %)

Temperature coefficient: ±0.015 %/°C (±0.008 %/°F)

CJC error: ±1.0°C at 25°C ±10°C

(±1.8°F at 77°F ±18°F)

±1.5°C (±2.7°F) for R, S, PR

T/C	BURNOUT INDICATION (°C)		CONFORMANCE RANGE (°C)
	Downscale	Upscale	
K (CA)	-272	+1472	-150 to +1370
E (CRC)	-272	+1120	-170 to +1000
J (IC)	-260	+1300	-180 to +1200
T (CC)	-272	+ 500	-170 to + 400
B (RH)	24	1920	400 to 1760
R	-100	+1860	200 to 1760
S	-100	+1860	0 to 1760
C (WRe 5-26)	-52	+2416	0 to 2315
N	-272	+1400	-130 to +1300
U	-252	+ 700	-200 to +600
L	-252	+1000	-200 to +900
P (Platinel II)	-52	+1496	0 to 1395
(PR)	-52	+1860	0 to 1760

T/C	BURNOUT INDICATION (°F)		CONFORMANCE RANGE (°F)
	Downscale	Upscale	
K (CA)	-458	+2682	-238 to +2498
E (CRC)	-458	+2048	-274 to +1832
J (IC)	-436	+2372	-292 to +2192
T (CC)	-458	+932	-274 to +752
B (RH)	75	3488	752 to 3200
R	-148	+3380	392 to 3200
S	-148	+3380	32 to 3200
C (WRe 5-26)	-62	+4381	32 to 4199
N	-458	+2552	-202 to +2372
U	-422	+1292	-328 to +1112
L	-422	+1832	-328 to +1652
P (Platinel II)	-62	+2725	32 to 2543
(PR)	-62	+3380	32 to 3200

OPERATING MODE SETTING

(*) Factory setting

• Thermocouple type (SW1-5, 1-6, 1-7, 1-8)

SW1-5	SW1-6	SW1-7	SW1-8	THERMOCOUPLE TYPE
OFF	OFF	OFF	OFF	K (CA) (*)
ON	OFF	OFF	OFF	E (CRC)
OFF	ON	OFF	OFF	J (IC)
ON	ON	OFF	OFF	T (CC)
OFF	OFF	ON	OFF	B (RH)
ON	OFF	ON	OFF	R
OFF	ON	ON	OFF	S
ON	ON	ON	OFF	C (WRe 5-26)
OFF	OFF	OFF	ON	N
ON	OFF	OFF	ON	U
OFF	ON	OFF	ON	L
ON	ON	OFF	ON	P (Platinel II)
OFF	OFF	ON	ON	(PR)
ON	ON	ON	ON	PC Configurator setting

• Conversion rate (SW1-3)

SW1-3	CONVERSION RATE
OFF	250 msec. (*)
ON	1 sec.

• Burnout (SW1-4)

SW1-4	BURNOUT
OFF	Upscale (*)
ON	Downscale

• Extension (SW1-1, 1-2)

SW1-1	SW1-2	EXTENSION
OFF	OFF	No extension (*)
ON	OFF	Discrete input, 8 or 16 points
OFF	ON	Discrete output, 8 or 16 points

TERMINAL ASSIGNMENTS

10	11	12	13	14	15	16	17	18
+IN0	-IN0	+IN1	-IN1	NC	+IN2	-IN2	+IN3	-IN3
1	2	3	4	5	6	7	8	9
+CJ0	-CJ0	+CJ1	-CJ1	NC	+CJ2	-CJ2	+CJ3	-CJ3

NO.	ID	FUNCTION	NO.	ID	FUNCTION
1	+CJ0	CJC 0	10	+IN0	T/C + 0
2	-CJ0	CJC 0	11	-IN0	T/C - 0
3	+CJ1	CJC 1	12	+IN1	T/C + 1
4	-CJ1	CJC 1	13	-IN1	T/C - 1
5	NC	No connection	14	NC	No connection
6	+CJ2	CJC 2	15	+IN2	T/C + 2
7	-CJ2	CJC 2	16	-IN2	T/C - 2
8	+CJ3	CJC 3	17	+IN3	T/C + 3
9	-CJ3	CJC 3	18	-IN3	T/C - 3



CIRCUIT DIAGRAM

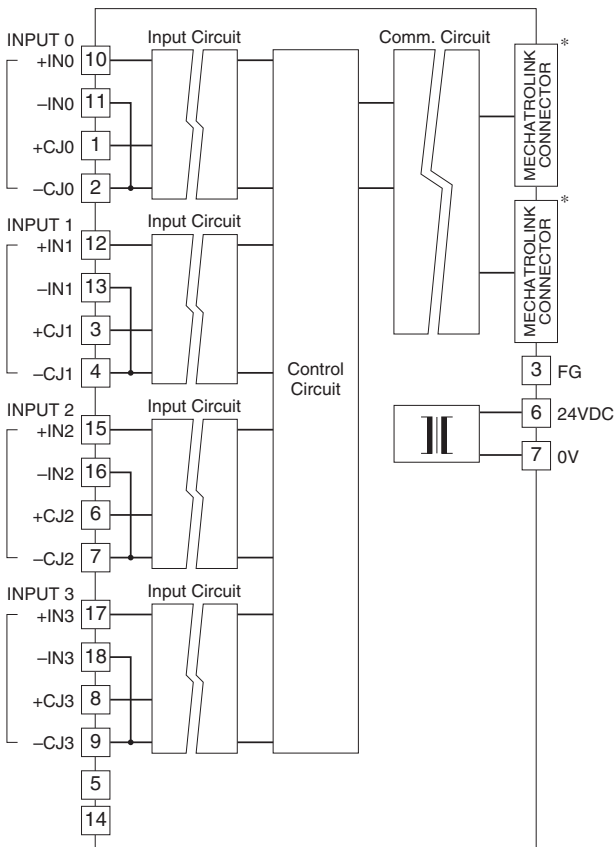

*MECHATROLINK connectors are internally connected.
The network cable can be connected to either one.

■ Input Connection Example

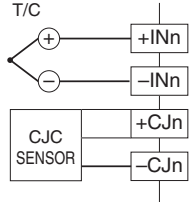

RTD INPUT MODULE, 4 points

MODEL: R7ML-RS4

SPECIFICATIONS

Isolation: Input 0 to input 1 to input 2 to input 3 to MECHATROLINK or FG to power input

Converted data range: Engineering unit value (°C, K) × 10 (integer); No multiplication for °F

RTD: Pt 100 (JIS '97, IEC), Pt 100 (JIS '89), JPt 100 (JIS '89), Pt 50 Ω (JIS '81), Ni 100, Cu 10, Cu 50

Sensing current: ≤ 1 mA

Input resistance: ≥ 1 MΩ

Maximum leadwire resistance: 100 Ω per wire

Conversion accuracy: ±1°C (±1.8°F);

±3°C (±5.4°F) for Cu 10

Conversion rate: 250 msec. or 1 sec.

Response time: Conversion rate × 2 + 50 msec. (0 - 90 %)

Temperature coefficient: ±0.015 %/°C (±0.008 %/°F)

RTD	BURNOUT INDICATION (°C)		CONFORMANCE RANGE (°C)
	Downscale	Upscale	
Pt 100 (JIS '97/IEC)	-240	+900	-200 to +850
Pt 100 (JIS '89)	-240	+900	-200 to +660
JPt 100 (JIS '89)	-236	+560	-200 to +510
Pt 50 Ω (JIS '81)	-236	+700	-200 to +649
Ni 100	-100	+252	-80 to +250
Cu 10 (25°C)	-212	+312	-50 to +250
Cu 50	-100	+200	-50 to +150

RTD	BURNOUT INDICATION (°F)		CONFORMANCE RANGE (°F)
	Downscale	Upscale	
Pt 100 (JIS '97/IEC)	-400	+1652	-328 to +1562
Pt 100 (JIS '89)	-400	+1652	-328 to +1220
JPt 100 (JIS '89)	-393	+1040	-328 to +950
Pt 50 Ω (JIS '81)	-393	+1292	-328 to +1200
Ni 100	-148	+486	-112 to +482
Cu 10 (25°C)	-350	+594	-58 to +482
Cu 50	-148	+392	-58 to +302

OPERATING MODE SETTING

(*) Factory setting

• **RTD type (SW1-5, 1-6, 1-7, 1-8)**

SW1-5	SW1-6	SW1-7	SW1-8	RTD TYPE
OFF	OFF	OFF	OFF	Pt 100 (JIS '97/IEC) (*)
ON	OFF	OFF	OFF	Pt 100 (JIS '89)
OFF	ON	OFF	OFF	JPt 100 (JIS '89)
ON	ON	OFF	OFF	Pt 50 Ω (JIS '81)
OFF	OFF	ON	OFF	Ni 100
ON	OFF	ON	OFF	Cu 10 (25°C)
OFF	OFF	OFF	ON	Cu 50
ON	ON	ON	ON	PC Configurator setting

• **Conversion rate (SW1-3)**

SW1-3	CONVERSION RATE
OFF	250 msec. (*)
ON	1 sec.

• **Burnout (SW1-4)**

SW1-4	BURNOUT
OFF	Upscale (*)
ON	Downscale

• **Extension (SW1-1, 1-2)**

SW1-1	SW1-2	EXTENSION
OFF	OFF	No extension (*)
ON	OFF	Discrete input, 8 or 16 points
OFF	ON	Discrete output, 8 or 16 points

TERMINAL ASSIGNMENTS

10 INA0	11 INb0	12 INA1	13 INb1	14 NC	15 INA2	16 INb2	17 INA3	18 INb3
1 NC	2 INB0	3 NC	4 INB1	5 NC	6 NC	7 INB2	8 NC	9 INB3

NO.	ID	FUNCTION	NO.	ID	FUNCTION
1	NC	No connection	10	INA0	RTD 0-A
2	INB0	RTD 0-B	11	INb0	RTD 0-b
3	NC	No connection	12	INA1	RTD 1-A
4	INB1	RTD 1-B	13	INb1	RTD 1-b
5	NC	No connection	14	NC	No connection
6	NC	No connection	15	INA2	RTD 2-A
7	INB2	RTD 2-B	16	INb2	RTD 2-b
8	NC	No connection	17	INA3	RTD 3-A
9	INB3	RTD 3-B	18	INb3	RTD 3-b



CIRCUIT DIAGRAM

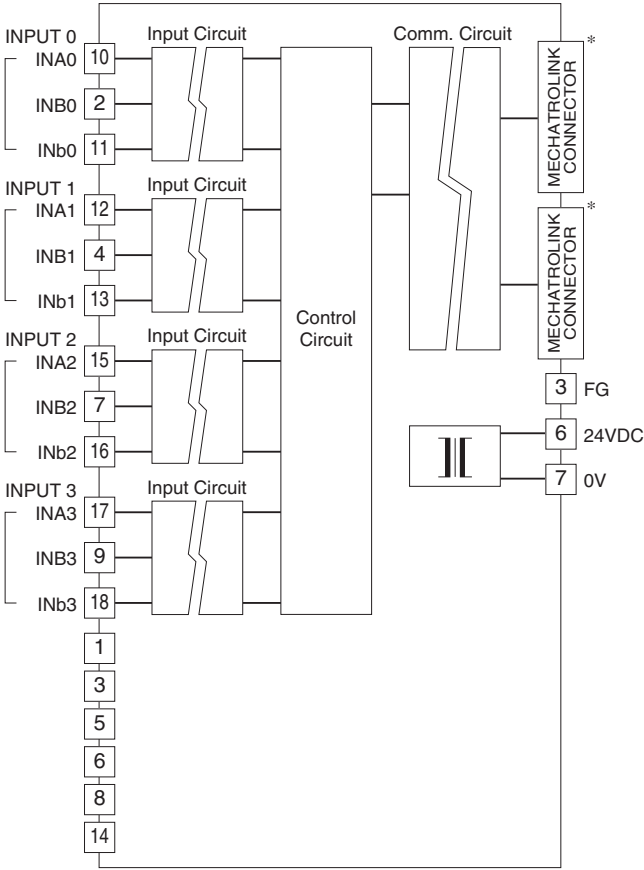

*MECHATROLINK connectors are internally connected.
The network cable can be connected to either one.

Input Connection Example

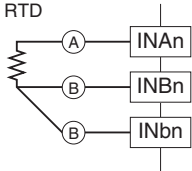

DC VOLTAGE OUTPUT MODULE, 2 points

MODEL: R7ML-YV2

SPECIFICATIONS

Isolation: Output 0 to output 1 to MECHATROLINK or FG to power input

Converted data range: 0 - 10000 of the output range

Output range

Wide span voltage: -10 - +10 V DC, -5 - +5 V DC, 0 - 10 V DC, 0 - 5 V DC, 1 - 5 V DC

Narrow span voltage: -1 - +1 V DC, 0 - 1 V DC, -0.5 - +0.5 V DC

Operational range: -15 - +115 % of the output range (except -10 - +10 V DC);

approx. -11.5 - +11.5 V DC (-10 - +10 V DC)

Load resistance: $\geq 100 \text{ k}\Omega$

Conversion accuracy: $\pm 0.1 \%$

Response time: 250 msec. (0 - 90 %)

Temperature coefficient: $\pm 0.015 \%/^{\circ}\text{C}$ ($\pm 0.008 \%/^{\circ}\text{F}$)

OPERATING MODE SETTING

(*) Factory setting

Caution ! - SW1-3 is unused. Be sure to turn off unused ones.

• Output range (SW1-5, 1-6, 1-7, 1-8)

SW1-5	SW1-6	SW1-7	SW1-8	OUTPUT RANGE
OFF	OFF	OFF	OFF	-10 - +10 V DC (*)
ON	OFF	OFF	OFF	-5 - +5 V DC
OFF	ON	OFF	OFF	-1 - +1 V DC
ON	ON	OFF	OFF	0 - 10 V DC
OFF	OFF	ON	OFF	0 - 5 V DC
ON	OFF	ON	OFF	1 - 5 V DC
OFF	ON	ON	OFF	0 - 1 V DC
ON	ON	ON	OFF	-0.5 - +0.5 V DC
ON	ON	ON	ON	PC Configurator setting

• Output at the loss of communication (SW1-4)

SW1-4	OUTPUT AT THE LOSS OF COMMUNICATION
OFF	Reset the output (to -15% or approx. -11.5V DC)
ON	Hold the output (*) (maintains the last data received normally)

• Extension (SW1-1, 1-2)

SW1-1	SW1-2	EXTENSION
OFF	OFF	No extension (*)
ON	OFF	Discrete input, 8 or 16 points
OFF	ON	Discrete output, 8 or 16 points

TERMINAL ASSIGNMENTS

6	7	8	9	10
NC	VH0	VL0	VH1	VL1
1	2	3	4	5
NC	COM0	COM0	COM1	COM1

NO.	ID	FUNCTION	NO.	ID	FUNCTION
1	NC	No connection	6	NC	No connection
2	COM0	Common 0	7	VH0	Wide span volt. 0
3	COM0	Common 0	8	VL0	Narrow span volt. 0
4	COM1	Common 1	9	VH1	Wide span volt. 1
5	COM1	Common 1	10	VL1	Narrow span volt. 1

CIRCUIT DIAGRAM

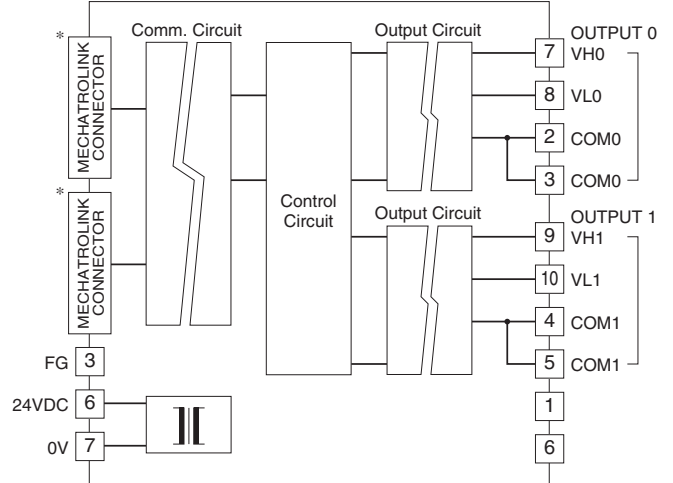

*MECHATROLINK connectors are internally connected. The network cable can be connected to either one.

■ Output Connection Examples



DC CURRENT OUTPUT MODULE, 2 points

MODEL: R7ML-YS2

SPECIFICATIONS

- Isolation:** Output 0 to output 1 to MECHATROLINK or FG to power input
- Converted data range:** 0 - 10000 of the output range
- Output range:** 4 - 20 mA DC
- Load resistance:** ≤ 600Ω
- Conversion accuracy:** ±0.1 %
- Response time:** 250 msec. (0 - 90 %)
- Temperature coefficient:** ±0.015 %/°C (±0.008 %/°F)

OPERATING MODE SETTING

(*) Factory setting

Caution ! - SW1-3, 1-5 through 1-8 are unused. Be sure to turn off unused ones.

• Output at the loss of communication (SW1-4)

SW1-4	OUTPUT AT THE LOSS OF COMMUNICATION
OFF	Reset the output (to -15%)
ON	Hold the output (*) (maintains the last data received normally)

• Extension (SW1-1, 1-2)

SW1-1	SW1-2	EXTENSION
OFF	OFF	No extension (*)
ON	OFF	Discrete input, 8 or 16 points
OFF	ON	Discrete output, 8 or 16 points

TERMINAL ASSIGNMENTS

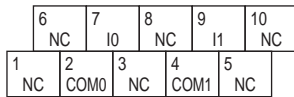

NO.	ID	FUNCTION	NO.	ID	FUNCTION
1	NC	No connection	6	NC	No connection
2	COM0	Common 0	7	I0	Current 0
3	NC	No connection	8	NC	No connection
4	COM1	Common 1	9	I1	Current 1
5	NC	No connection	10	NC	No connection

CIRCUIT DIAGRAM

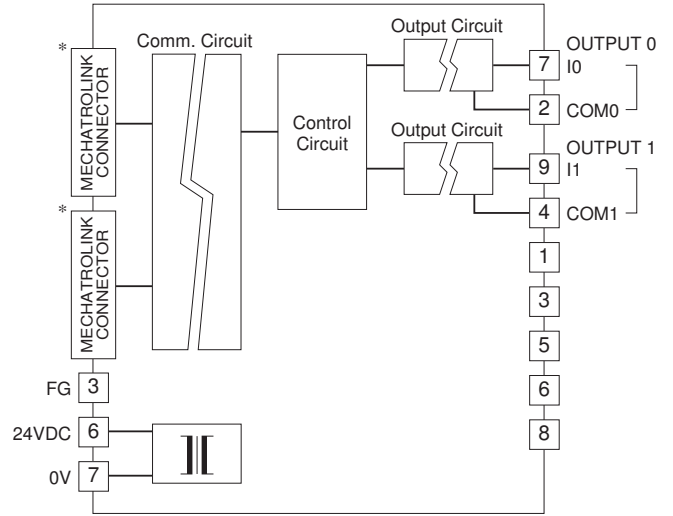

*MECHATROLINK connectors are internally connected. The network cable can be connected to either one.



DISCRETE INPUT EXTENSION MODULE, 8 points

CIRCUIT DIAGRAM

MODEL: R7ML-EA8

SPECIFICATIONS

- Common:** Positive or negative common (NPN/PNP) per 8 points
- Number of I/O:** Input, 8 points
- Maximum inputs applicable at once:** No limit (at 24 V DC)
- I/O status indicator:** LED turns on with closed contact.
- Isolation:** Input to internal circuits
- Rated input voltage:** 24 V DC $\pm 10\%$; ripple 5 %p-p max.
- ON voltage / current:** ≥ 15 V DC (input - COM) / ≥ 3.5 mA
- OFF voltage / current:** ≤ 5 V DC (input - COM) / ≤ 1 mA
- Input current:** ≤ 5.5 mA per point at 24 V DC
- Input resistance:** Approx. 4.4 k Ω
- ON delay:** ≤ 2.0 msec.
- OFF delay:** ≤ 2.0 msec.

TERMINAL ASSIGNMENTS

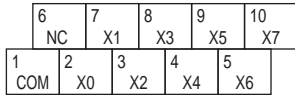

NO.	ID	FUNCTION	NO.	ID	FUNCTION
1	COM	Common	6	NC	No Connection
2	X0	Input 0	7	X1	Input 1
3	X2	Input 2	8	X3	Input 3
4	X4	Input 4	9	X5	Input 5
5	X6	Input 6	10	X7	Input 7

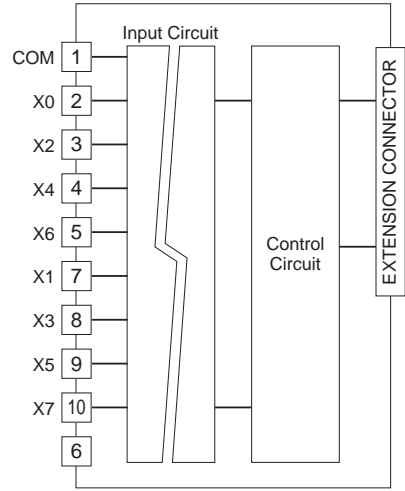

Input Circuit

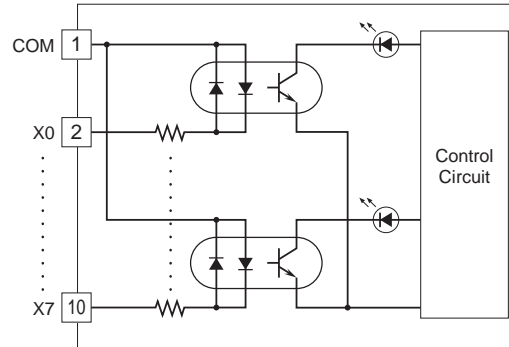

Input Connection Examples

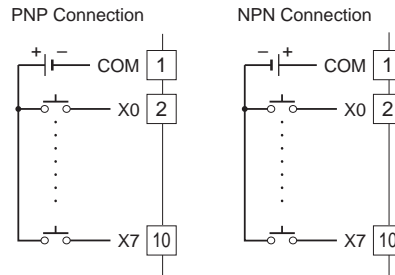

DISCRETE INPUT EXTENSION MODULE, 16 points

CIRCUIT DIAGRAM

MODEL: R7ML-EA16

SPECIFICATIONS

- Common:** Positive or negative common (NPN/PNP) per 16 points
- Number of I/O:** Input, 16 points
- Maximum inputs applicable at once:** No limit (at 24 V DC)
- I/O status indicator:** LED turns on with closed contact.
- Isolation:** Input to internal circuits
- Rated input voltage:** 24 V DC $\pm 10\%$; ripple 5 %p-p max.
- ON voltage / current:** ≥ 15 V DC (input - COM) / ≥ 3.5 mA
- OFF voltage / current:** ≤ 5 V DC (input - COM) / ≤ 1 mA
- Input current:** ≤ 5.5 mA per point at 24 V DC
- Input resistance:** Approx. 4.4 k Ω
- ON delay:** ≤ 2.0 msec.
- OFF delay:** ≤ 2.0 msec.

TERMINAL ASSIGNMENTS

10	11	12	13	14	15	16	17	18
NC	X1	X3	X5	X7	X9	XB	XD	XF
1	2	3	4	5	6	7	8	9
COM	X0	X2	X4	X6	X8	XA	XC	XE

NO.	ID	FUNCTION	NO.	ID	FUNCTION
1	COM	Common	10	NC	No Connection
2	X0	Input 0	11	X1	Input 1
3	X2	Input 2	12	X3	Input 3
4	X4	Input 4	13	X5	Input 5
5	X6	Input 6	14	X7	Input 7
6	X8	Input 8	15	X9	Input 9
7	XA	Input 10	16	XB	Input 11
8	XC	Input 12	17	XD	Input 13
9	XE	Input 14	18	XF	Input 15

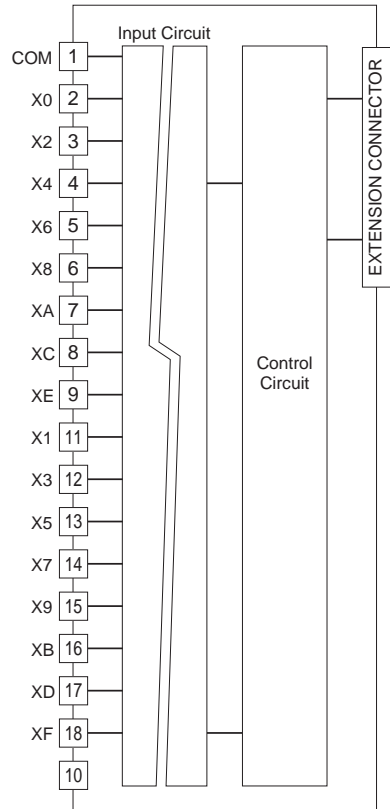

Input Circuit

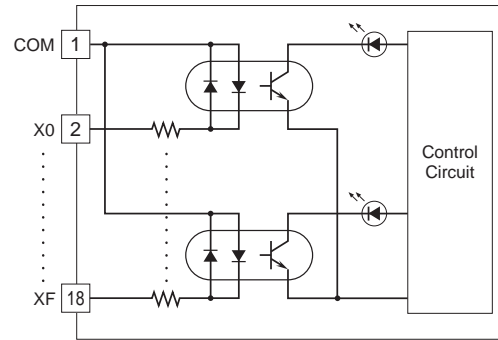

Input Connection Examples

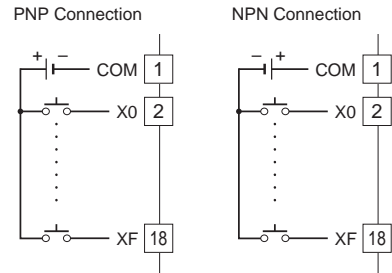

MODEL: R7ML

NPN TRANSISTOR OUTPUT EXTENSION MODULE, 8 points

CIRCUIT DIAGRAM

MODEL: R7ML-EC8A

SPECIFICATIONS

- Common:** Negative common (NPN) per 8 points
- Number of I/O:** Output, 8 points
- Maximum outputs applicable at once:** No limit (at 24 V DC)
- I/O status indicator:** LED turns on with closed contact.
- Isolation:** Output to internal circuits
- Rated load voltage:** 24 V DC $\pm 10\%$
- Rated output current:** 0.25 A per point, 2.0 A per common
- Residual voltage:** ≤ 1.2 V
- Leakage current:** ≤ 0.1 mA
- ON delay:** ≤ 0.5 msec.
- OFF delay:** ≤ 1.5 msec.

TERMINAL ASSIGNMENTS

6	7	8	9	10
+24 V	Y1	Y3	Y5	Y7
1	2	3	4	5
0 V	Y0	Y2	Y4	Y6

NO.	ID	FUNCTION	NO.	ID	FUNCTION
1	0 V	0 V (common)	6	+24 V	24 V DC
2	Y0	Output 0	7	Y1	Output 1
3	Y2	Output 2	8	Y3	Output 3
4	Y4	Output 4	9	Y5	Output 5
5	Y6	Output 6	10	Y7	Output 7

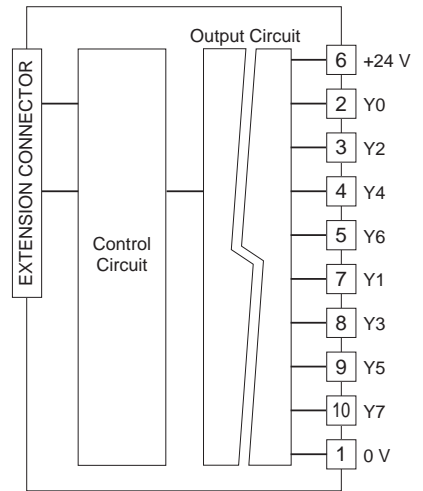

Output Circuit

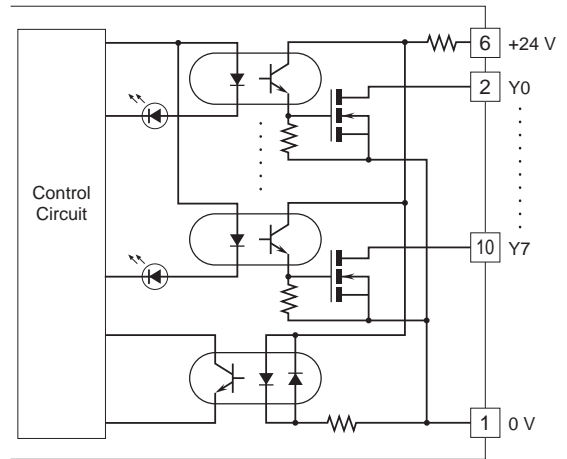

Output Connection Example

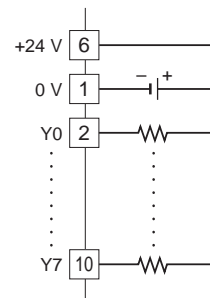

NPN TRANSISTOR OUTPUT EXTENSION MODULE, 16 points

CIRCUIT DIAGRAM

MODEL: R7ML-EC16A

SPECIFICATIONS

- Common:** Negative common (NPN) per 16 points
- Number of I/O:** Output, 16 points
- Maximum outputs applicable at once:** No limit (at 24 V DC)
- I/O status indicator:** LED turns on with closed contact.
- Isolation:** Output to internal circuits
- Rated load voltage:** 24 V DC $\pm 10\%$
- Rated output current:** 0.25 A per point, 2.0 A per common
- Residual voltage:** ≤ 1.2 V
- Leakage current:** ≤ 0.1 mA
- ON delay:** ≤ 0.5 msec.
- OFF delay:** ≤ 1.5 msec.

TERMINAL ASSIGNMENTS

10	11	12	13	14	15	16	17	18
+24 V	Y1	Y3	Y5	Y7	Y9	YB	YD	YF
1	2	3	4	5	6	7	8	9
0 V	Y0	Y2	Y4	Y6	Y8	YA	YC	YE

NO.	ID	FUNCTION	NO.	ID	FUNCTION
1	0 V	0 V (common)	10	+24 V	24 V DC
2	Y0	Output 0	11	Y1	Output 1
3	Y2	Output 2	12	Y3	Output 3
4	Y4	Output 4	13	Y5	Output 5
5	Y6	Output 6	14	Y7	Output 7
6	Y8	Output 8	15	Y9	Output 9
7	YA	Output 10	16	YB	Output 11
8	YC	Output 12	17	YD	Output 13
9	YE	Output 14	18	YF	Output 15

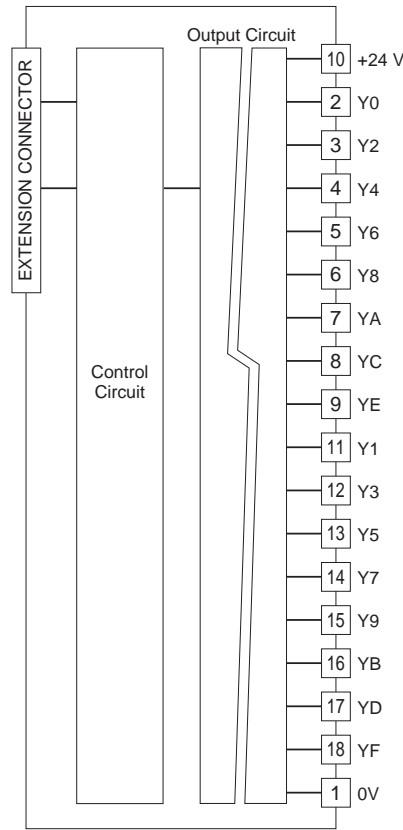

■ Output Circuit

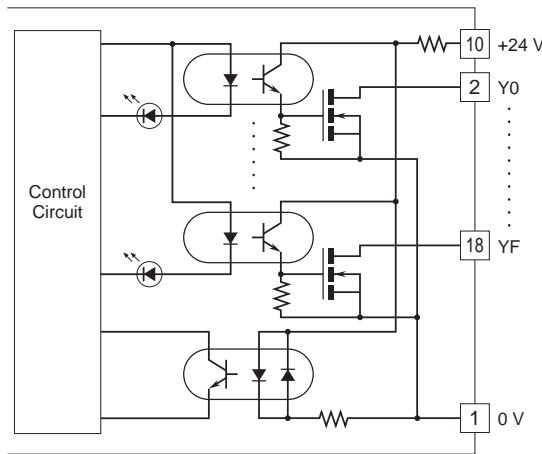

■ Output Connection Example

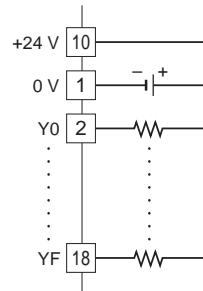

MODEL: R7ML

PNP TRANSISTOR OUTPUT EXTENSION MODULE, 8 points

CIRCUIT DIAGRAM

MODEL: R7ML-EC8B

SPECIFICATIONS

- Common:** Positive common (PNP) per 8 points
- Number of I/O:** Output, 8 points
- Maximum outputs applicable at once:** No limit (at 24 V DC)
- I/O status indicator:** LED turns on with closed contact.
- Isolation:** Output to internal circuits
- Rated load voltage:** 24 V DC $\pm 10\%$
- Rated output current:** 0.25 A per point, 2.0 A per common
- Residual voltage:** ≤ 1.2 V
- Leakage current:** ≤ 0.1 mA
- ON delay:** ≤ 0.5 msec.
- OFF delay:** ≤ 1.5 msec.

TERMINAL ASSIGNMENTS

6	7	8	9	10
+24 V	Y1	Y3	Y5	Y7
1	2	3	4	5
0 V	Y0	Y2	Y4	Y6

NO.	ID	FUNCTION	NO.	ID	FUNCTION
1	0 V	0 V	6	+24 V	24 V DC (common)
2	Y0	Output 0	7	Y1	Output 1
3	Y2	Output 2	8	Y3	Output 3
4	Y4	Output 4	9	Y5	Output 5
5	Y6	Output 6	10	Y7	Output 7

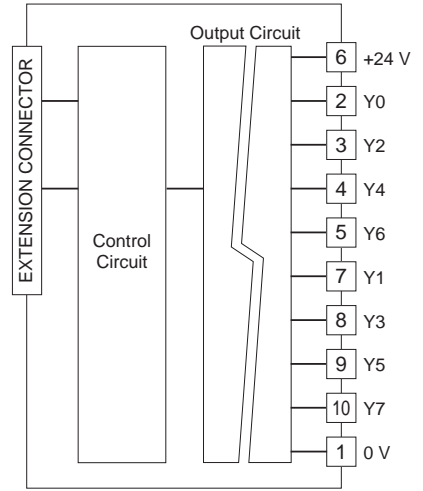

Output Circuit

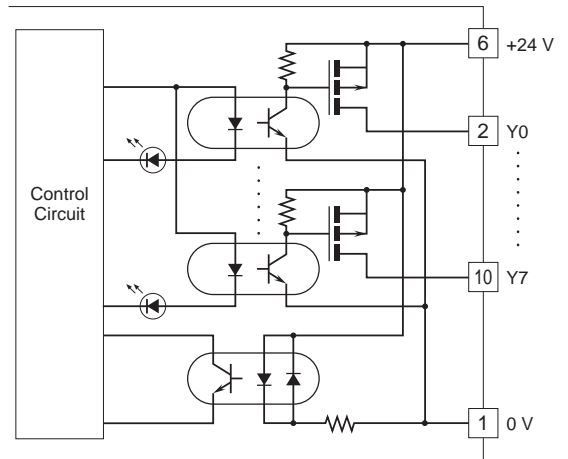

Output Connection Example

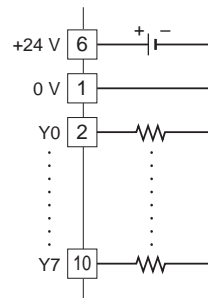

MODEL: R7ML

PNP TRANSISTOR OUTPUT EXTENSION MODULE, 16 points

CIRCUIT DIAGRAM

MODEL: R7ML-EC16B

SPECIFICATIONS

- Common:** Positive common (PNP) per 16 points
- Number of I/O:** Output, 16 points
- Maximum outputs applicable at once:** No limit (at 24 V DC)
- I/O status indicator:** LED turns on with closed contact.
- Isolation:** Output to internal circuits
- Rated load voltage:** 24 V DC $\pm 10\%$
- Rated output current:** 0.25 A per point, 2.0 A per common
- Residual voltage:** ≤ 1.2 V
- Leakage current:** ≤ 0.1 mA
- ON delay:** ≤ 0.5 msec.
- OFF delay:** ≤ 1.5 msec.

TERMINAL ASSIGNMENTS

10	11	12	13	14	15	16	17	18
+24 V	Y1	Y3	Y5	Y7	Y9	YB	YD	YF
1	2	3	4	5	6	7	8	9
0 V	Y0	Y2	Y4	Y6	Y8	YA	YC	YE

NO.	ID	FUNCTION	NO.	ID	FUNCTION
1	0 V	0 V	10	+24 V	24 V DC (common)
2	Y0	Output 0	11	Y1	Output 1
3	Y2	Output 2	12	Y3	Output 3
4	Y4	Output 4	13	Y5	Output 5
5	Y6	Output 6	14	Y7	Output 7
6	Y8	Output 8	15	Y9	Output 9
7	YA	Output 10	16	YB	Output 11
8	YC	Output 12	17	YD	Output 13
9	YE	Output 14	18	YF	Output 15

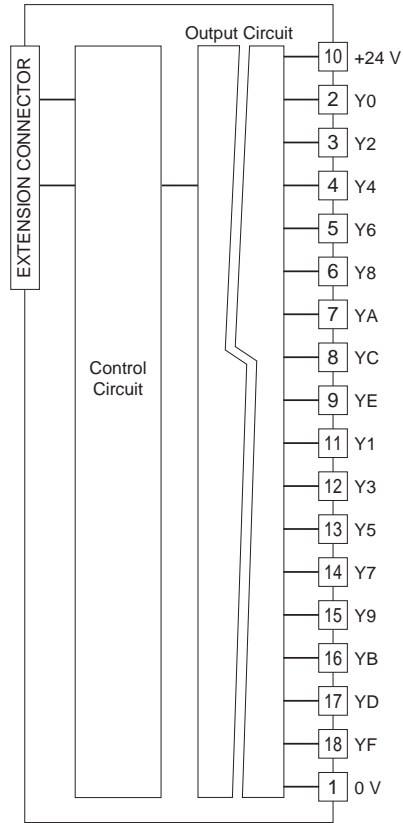

Output Circuit

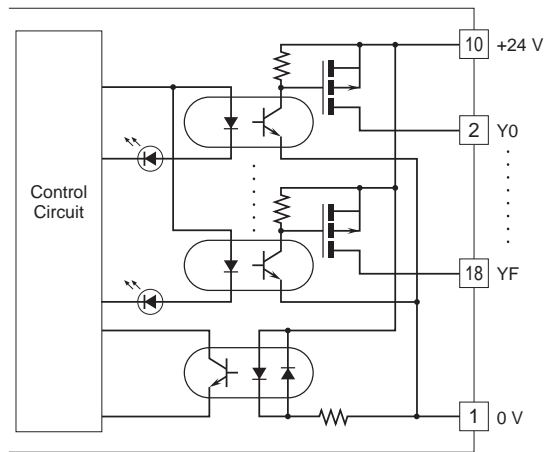

Output Connection Example

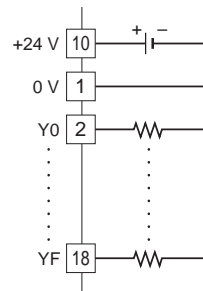

幸託有限公司
XIN TOP CORPORATION

TEL : (02)2598-1199
FAX : (02)2596-2331

E-mail : info@xintop.com
Website : www.xintop.com

MODEL: R7ML

PNP TRANSISTOR OUTPUT EXTENSION MODULE, 8 points
(shortcircuit protection)

CIRCUIT DIAGRAM

MODEL: R7ML-EC8D

SPECIFICATIONS

- Common:** Positive common (PNP) per 8 points
- Number of I/O:** Output, 8 points
- Maximum outputs applicable at once:** No limit (at 24 V DC)
- I/O status indicator:** LED turns on with closed contact.
- Isolation:** Output to internal circuits
- Rated load voltage**
 - Nominal:** 19.2 to 30 V DC
 - Absolute:** 15 to 45 V DC
- Rated output current:** 0.25 A per point, 2.0 A per common
- Residual voltage:** ≤ 2.0 V
- Leakage current:** ≤ 0.3 mA (24 V DC load, all points OFF)
- ON delay:** ≤ 0.5 msec.
- OFF delay:** ≤ 1.5 msec.
- Shortcircuit protection:** Works for 0.7 A or more; automatically resets after recovery

TERMINAL ASSIGNMENTS

6	7	8	9	10
+24 V	Y1	Y3	Y5	Y7
1	2	3	4	5
0 V	Y0	Y2	Y4	Y6

NO.	ID	FUNCTION	NO.	ID	FUNCTION
1	0 V	0 V	6	+24 V	24 V DC (common)
2	Y0	Output 0	7	Y1	Output 1
3	Y2	Output 2	8	Y3	Output 3
4	Y4	Output 4	9	Y5	Output 5
5	Y6	Output 6	10	Y7	Output 7

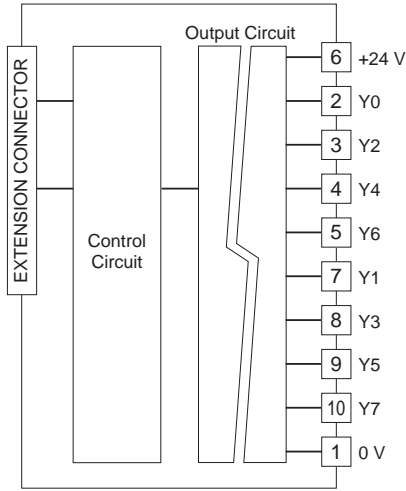

Output Circuit

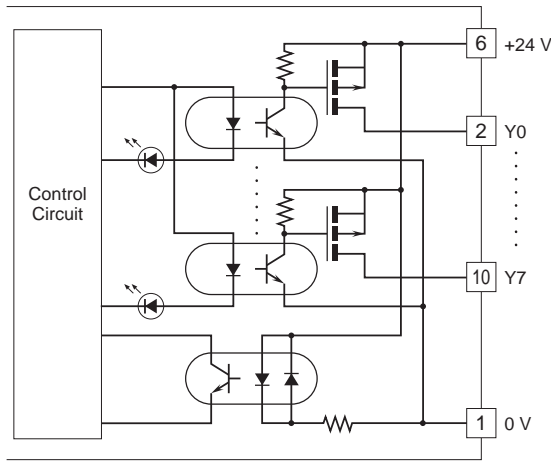

Output Connection Example

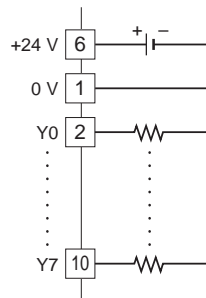

MODEL: R7ML

PNP TRANSISTOR OUTPUT EXTENSION MODULE, 16 points
(shortcircuit protection)

CIRCUIT DIAGRAM

MODEL: R7ML-EC16D

SPECIFICATIONS

- Common:** Positive common (PNP) per 16 points
- Number of I/O:** Output, 16 points
- Maximum outputs applicable at once:** No limit (at 24 V DC)
- I/O status indicator:** LED turns on with closed contact.
- Isolation:** Output to internal circuits
- Rated load voltage**
 - Nominal:** 19.2 to 30 V DC
 - Absolute:** 15 to 45 V DC
- Rated output current:** 0.25 A per point, 2.0 A per common
- Residual voltage:** ≤ 2.0 V
- Leakage current:** ≤ 0.3 mA (24 V DC load, all points OFF)
- ON delay:** ≤ 0.5 msec.
- OFF delay:** ≤ 1.5 msec.
- Shortcircuit protection:** Works for 0.7 A or more; automatically resets after recovery

TERMINAL ASSIGNMENTS

10	11	12	13	14	15	16	17	18
+24 V	Y1	Y3	Y5	Y7	Y9	YB	YD	YF
1	2	3	4	5	6	7	8	9
0 V	Y0	Y2	Y4	Y6	Y8	YA	YC	YE

NO.	ID	FUNCTION	NO.	ID	FUNCTION
1	0 V	0 V	10	+24 V	24 V DC (common)
2	Y0	Output 0	11	Y1	Output 1
3	Y2	Output 2	12	Y3	Output 3
4	Y4	Output 4	13	Y5	Output 5
5	Y6	Output 6	14	Y7	Output 7
6	Y8	Output 8	15	Y9	Output 9
7	YA	Output 10	16	YB	Output 11
8	YC	Output 12	17	YD	Output 13
9	YE	Output 14	18	YF	Output 15

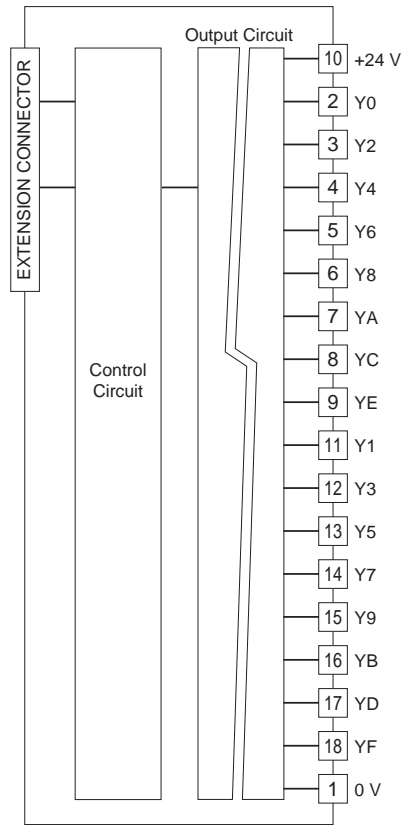

Output Circuit

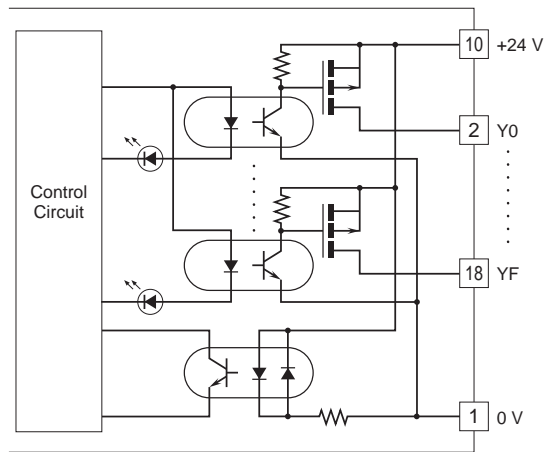

Output Connection Example

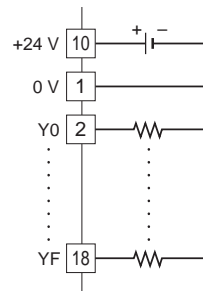



Specifications are subject to change without notice.

