

Remote I/O R7 Series

MODBUS I/O MODULE

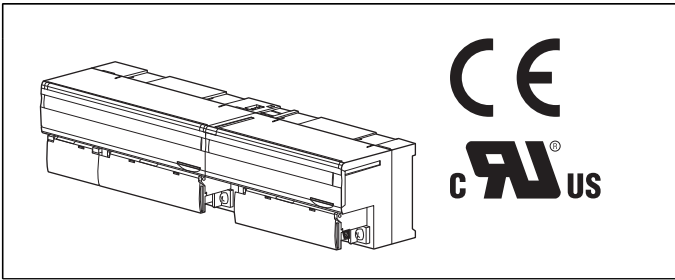

ORDERING INFORMATION

- Basic module: R7M-[1]-[2][3]
Specify a code from below for each [1] through [3].
(e.g. R7M-DC16A-R/UL/Q)
- Specify the specification for option code /Q
(e.g. /SET)
- Extension module: R7M-[1][2]
Specify a code from below for each [1] and [2].
(e.g. R7M-EC16A/UL)

BASIC MODULE: R7M-[1]-[2][3]

[1] I/O TYPE

- DA16:** Discrete input, 16 points
- DA16F:** Discrete input, 16 points
(115.2 kbps, Option /UL Not selectable)
(Terminating resistor incorporated)
- DC16A:** NPN transistor output, 16 points
- DC16B:** PNP transistor output, 16 points
- DAC16C:** NPN discrete input &
NPN transistor output, 8 points each
(115.2 kbps, option /UL Not selectable)
(Terminating resistor incorporated)
- DAC16D:** PNP discrete input &
PNP transistor output, 8 points each
(115.2 kbps, option /UL Not selectable)
(Terminating resistor incorporated)
- DC8C:** Relay contact output, 8 points
(Option /UL Not selectable)
(Not usable with 'extension' modules)
- RR8:** Remote control relay control, 8 points
(115.2 kbps, CE not available, option /UL Not selectable)
(Terminating resistor incorporated)
- SV4:** DC voltage/current input (10 V / 20 mA), 4 points
- TS4:** Thermocouple input, 4 points
- RS4:** RTD input, 4 points
- MS4:** Potentiometer input, 4 points (Option /UL Not selectable)

- CT4E:** AC current input, 4 points,
Clamp-on current sensor CLSE use
(Option /UL Not selectable)
- PA8:** Totalized pulse input, 8 points,
(115.2 kbps, CE not available, option /UL Not selectable)
(Terminating resistor incorporated)
- YV2:** DC voltage output, 2 points
- YS2:** DC current output, 2 points

[2] POWER INPUT

- DC power**
- R:** 24 V DC
- Universal**
- AR:** 24 V AC/DC (Only for R7M-PA8 and RR8)

[3] OPTIONS

- Standards & Approvals**
- blank:** CE marking (Refer I/O TYPE code for exception)
- /UL:** UL approval, CE marking
- Other Options**
- blank:** none
- /Q:** Option other than the above (specify the specification)
(UL not available)

SPECIFICATIONS OF OPTION: Q

- EX-FACTORY SETTING**
- /SET:** Preset according to the Ordering Information Sheet
(No. ESU-7803-x)

EXTENSION MODULE: R7M-[1][2]

[1] I/O TYPE

- EA8:** Discrete input, 8 points
- EA16:** Discrete input, 16 points
- EC8A:** NPN transistor output, 8 points
- EC16A:** NPN transistor output, 16 points
- EC8B:** PNP transistor output, 8 points
- EC16B:** PNP transistor output, 16 points
- EC8C:** Relay contact output, 8 points
(CE not available. Option /UL Not selectable.)

[2] OPTIONS

- STANDARDS & APPROVALS**
- blank:** CE marking (Refer I/O TYPE code for exception)
- /UL:** UL approval, CE marking

FUNCTIONS & FEATURES

The R7M interfaces analog and discrete I/O signals with a PC via Modbus.



A 'basic' module can be attached with an 'extension' module.

(R7M-DC8C can not be attached with an 'extension' module.)

By combining two modules, single station can handle mixed analog and discrete signals, 32-point discrete inputs, 32-point discrete outputs, 16-point discrete I/Os and other combinations of signals.

Input sensor type (thermocouple, RTD) and range can be selected with the front DIP switches for all channels.

In order to set different selections for individual channels, zero/span adjustments, scaling and temperature unit, use the PC Configurator Software (model: R7CON)

RELATED PRODUCTS

- PC configurator software (model: R7CON)

Downloadable at M-System's web site.

A dedicated cable is required to connect the module to the PC. Please refer to the internet software download site or the users manual for the PC configurator for applicable cable types.

PACKAGE INCLUDES...

- Terminating resistor (110 Ω, 0.25 W)
- (Not provided for models terminating resistor incorporated)

GENERAL SPECIFICATIONS

- Common Specifications

Power input:

24 V AC ±10 % (50 / 60 Hz)

24 V DC ±10 %; ripple 10 %p-p max.

Insulation resistance: ≥ 100 MΩ with 500 V DC

Dielectric strength: 1500 V AC @1 minute
(between isolated circuits)

Operating temperature: -10 to +55°C (14 to 131°F)

Operating humidity: 30 to 90 %RH (non-condensing)

Atmosphere: No corrosive gas or heavy dust

Storage temperature: -20 to +65°C (-4 to +149°F)

Mounting: DIN rail (35 mm wide)

Connection: M3 screw terminals (torque 0.5 N·m)

Screw terminal material: Nickel-plated steel

Solderless terminal: Refer to the drawing at the end of the section.

Recommended manufacturer: Japan Solderless Terminal MFG.Co.Ltd, Nichifu Co.,Ltd

Applicable wire size: 0.25 to 1.65 mm² (AWG 22 to 16)

Status indicator LEDs: PWR, RUN, ERR, SD, RD

(Refer to the instruction manual for details)

■ Current Consumption approximated at 24 V DC; Weight

R7M-DA16: 60 mA; 200 g (7.1 oz)

R7M-DA16F: 40 mA; 200 g (7.1 oz)

R7M-DC16A: 70 mA; 200 g (7.1 oz)

R7M-DC16B: 70 mA; 200 g (7.1 oz)

R7M-DAC16C: 40 mA; 200 g (7.1 oz)

R7M-DAC16D: 40 mA; 200 g (7.1 oz)

R7M-DC8C: 60 mA (60 mA); 200 g (7.1 oz)

R7M-RR8: 60 mA; 200 g (7.1 oz)

R7M-SV4: 90 mA; 200 g (7.1 oz)

R7M-TS4: 90 mA; 200 g (7.1 oz)

R7M-RS4: 90 mA; 200 g (7.1 oz)

R7M-MS4: 80 mA; 200 g (7.1 oz)

R7M-CT4E: 100 mA; 200 g (7.1 oz)

R7M-PA8: 40 mA; 200 g (7.1 oz)

R7M-YV2: 100 mA; 180 g (6.3 oz)

R7M-YS2: 140 mA; 180 g (6.3 oz)

R7M-EA8: 10 mA; 90 g (3.2 oz)

R7M-EA16: 20 mA; 150 g (5.3 oz)

R7M-EC8A: 10 mA; 90 g (3.2 oz)

R7M-EC16A: 20 mA; 150 g (5.3 oz)

R7M-EC8B: 10 mA; 90 g (3.2 oz)

R7M-EC16B: 20 mA; 150 g (5.3 oz)

R7M-EC8C: 40 mA (60mA); 150 g (5.3 oz)

The consumed current of supply power for the output is shown in ().

• Current Consumption (at 24 V AC)

R7M-RR8: 140 mA

R7M-PA8: Approx. 75 mA

■ Recommended solderless terminal

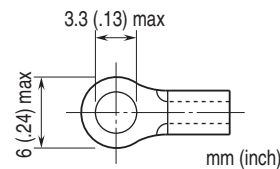

MODBUS COMMUNICATION

RS-485

Standard: Conforms to TIA/EIA-485-A

Transmission distance: 500 meters max.

Transmission media: Shielded twisted-pair cable (CPEV-S 0.9 dia.)

■ MODBUS COMMUNICATION PARAMETERS

| PARAMETER | SELECTIONS | SETTING |
|---|---|-----------|
| Data Mode | RTU (*) / ASCII | R7CON |
| Baud Rate | 38.4 kbps (*) / 19.2 kbps / 9600 bps / 4800 bps | Rotary SW |
| Baud Rate (R7M-PA8, DA16F, DAC16C, DAC16D, RR8) | 115.2 kbps / 57.6 kbps / 38.4 kbps(*) / 28.8 kbps / 19.2 kbps / 14.4 kbps / 9600 bps / 4800 bps / 2400 bps / 1200 bps | Rotary SW |
| Parity | NONE (*) / ODD / EVEN | R7CON |
| Bit Length | 8: RTU (*) / 7: ASCII | R7CON |
| Stop Bit | 2 (*) / 1 | R7CON |
| Node Address | 1 to 99 (*00) | Rotary SW |

(*) Factory setting



STANDARDS & APPROVALS

Refer to the manuals to comply with the standards.

CE conformity:

EMC Directive (2004/108/EC)

EMI EN 61000-6-4: 2007/A1: 2011

EMS EN 61000-6-2: 2005

Low Voltage Directive (2006/95/EC)

(R7M-DC8C only. Refer to the instruction manual for the detailed information)

EN 61010-1: 2010

Measurement Category II

Pollution degree 2

Output to power: Basic insulation (300 V)

Approval:

UL/C-UL nonincendive Class I, Division 2,

Groups A, B, C, and D

(ANSI/ISA-12.12.01:2013, CAN/CSA-C22.2 No.213:1987)

UL/C-UL general safety requirements

(UL 61010-1:2004, CAN/CSA-C22.2 No.61010-1:2004)

EXTERNAL VIEW

■ **BASIC MODULE**

• **SIDE VIEW**

• **FRONT VIEW**

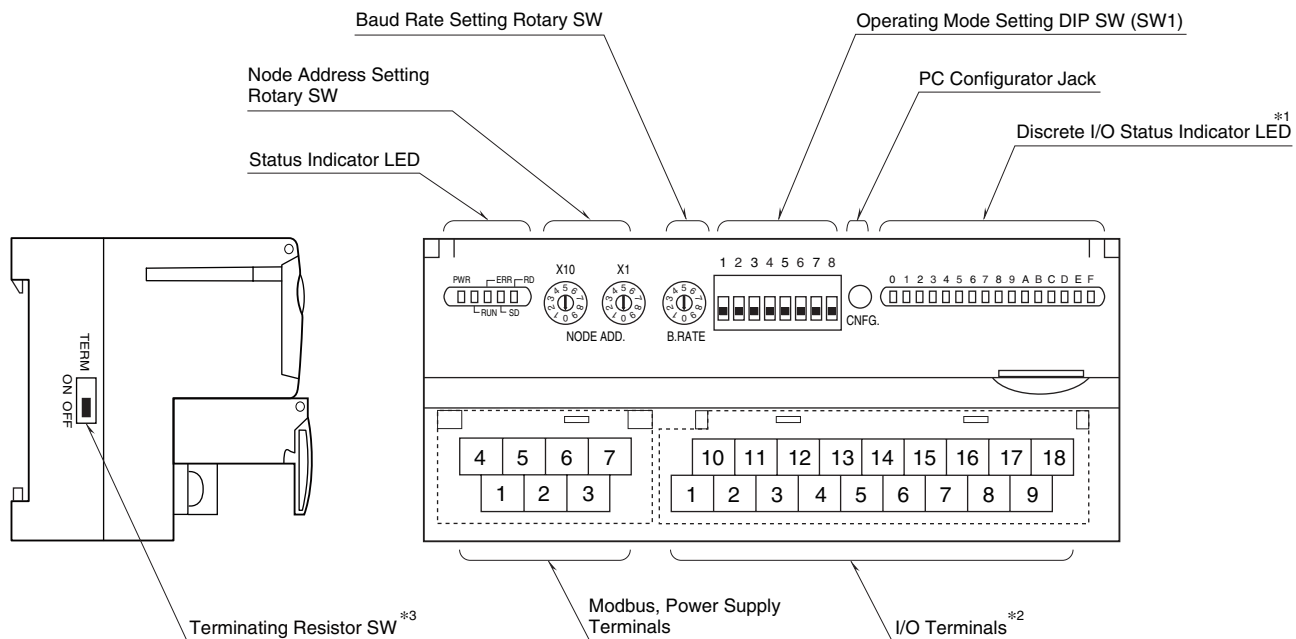

*1. Not available with analog I/O modules.
 *2. 10 screw terminals for analog output modules.
 *3. Only for R7M-PA8, DA16F, DAC16x and RR8.



■ EXTENSION MODULE

• DISCRETE, 8 POINTS

Discrete I/O Status Indicator LED

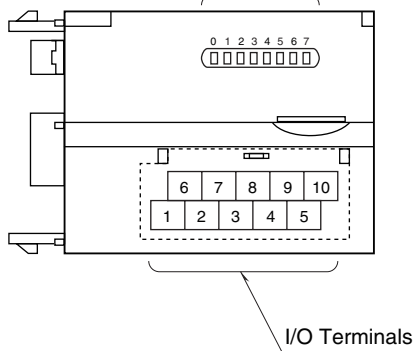

• DISCRETE, 16 POINTS

Discrete I/O Status Indicator LED

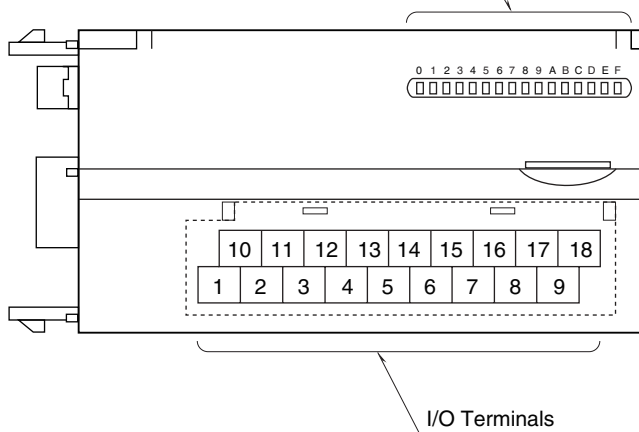

■ DISCRETE I/O STATUS INDICATOR LED

Discrete I/O modules, including those for extensions, have LED indicators showing I/O signal status.

Totalized pulse modules have LED indicators showing input signal status.

Contact ON : LED ON

Contact OFF : LED OF

CONNECTION DIAGRAMS

POWER SUPPLY, MODBUS TERMINAL ASSIGNMENT

• Except R7M-PA8 and RR8

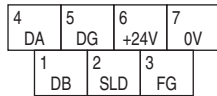

| NO. | ID | FUNCTION, NOTES |
|-----|------|----------------------|
| 1 | DB | ---- |
| 2 | SLD | Shield |
| 3 | FG | FG |
| 4 | DA | ---- |
| 5 | DG | ---- |
| 6 | +24V | Power input (24V DC) |
| 7 | 0V | Power input (0V) |

• R7M-PA8, RR8

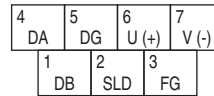

| NO. | ID | FUNCTION, NOTES |
|-----|-------|-----------------|
| 1 | DB | ---- |
| 2 | SLD | Shield |
| 3 | FG | FG |
| 4 | DA | ---- |
| 5 | DG | ---- |
| 6 | U (+) | Power input |
| 7 | V (-) | Power input |

MASTER CONNECTION

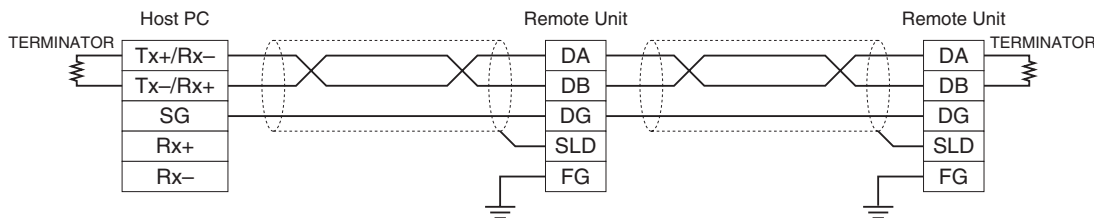

Be sure to connect the terminating resistor included in the product package to the unit at both ends of transmission line.
The terminator must be connected across DA and DB.
The Host PC can be located other than at the extreme ends of transmission line.

MODBUS FUNCTION CODES & SUPPORTED CODES

Data and Control Functions

| CODE | NAME | |
|------|---------------------------|---|
| 01 | Read Coil Status | Digital output from the slave (read/write) |
| 02 | Read Input Status | Status of digital inputs to the slave (read only) |
| 03 | Read Holding Registers | General purpose register within the slave (read/write) |
| 04 | Read Input Registers | Collected data from the field by the slave (read only) |
| 05 | Force Single Coil | Digital output from the slave (read/write) |
| 06 | Preset Single Registers | General purpose register within the slave (read/write) |
| 08 | Diagnostics | |
| 11 | Fetch Comm. Event Counter | Fetch a status word and an event counter |
| 12 | Fetch Comm. Event Log | A status word, an event counter, a message count and a field of event bytes |
| 15 | Force Multiple Coils | Digital output from the slave (read/write) |
| 16 | Preset Multiple Registers | General purpose register within the slave (read/write) |
| 17 | Report Slave ID | Slave type/ 'RUN'status |

Exception Codes

| CODE | NAME | |
|------|----------------------|--|
| 01 | Illegal Function | Function code is not allowable for the slave |
| 02 | Illegal Data Address | Address is not available within the slave |
| 03 | Illegal Data Value | Data is not valid for the function |

Diagnostic Subfunctions

| CODE | NAME | |
|------|-------------------|----------------|
| 00 | Return Query Data | Loop back test |



MODBUS I/O ASSIGNMENTS

| | ADDRESS | DATA TYPE | DATA |
|------------------------|---------|-----------|--|
| Coil (0X) | 1 – 16 | | Digital Output (discrete output of the basic module) |
| | 17 – 32 | | Digital Output (discrete output of the extension module) |
| Inputs (1X) | 1 – 16 | | Digital Input (discrete input of the basic module) |
| | 17 – 32 | | Digital Input (discrete input of the extension module) |
| | 33 – 48 | | Reserved (unused) |
| | 49 – 64 | | Module Status |
| | 65 – 80 | | Reserved (unused) |
| Input Registers (3X) | 1 – 4 | I | Analog Input |
| | 5 – 16 | ---- | Reserved (unused) |
| | 17 – 24 | F | Analog Input |
| | 25 – 48 | ---- | Reserved (unused) |
| Holding Registers (4X) | 1 – 2 | I | Analog Output |
| | 3 – 16 | ---- | Reserved (unused) |
| | 17 – 20 | F | Analog Output |
| | 21 – 48 | ---- | Reserved (unused) |

I : Integer, -1500 – 11500 (-15 – 115%)

F : Floating

Note: DO NOT access addresses other than mentioned above. Such access may cause problems such as inadequate operation.

■ STATUS

Analog input modules (models: R7M-SV4, R7M-TS4, R7M-RS4, R7M-MS4, R7M-CT4E) can show input status of each channel.

Analog output modules (models: R7M-YS2, R7M-YV2),
discrete I/O modules (models: R7M-DA16x, R7M-DCx, R7M-DAC16x, R7M-RR8),
totalized pulse input module (model: R7M-PA8) shows '0' at the same address.

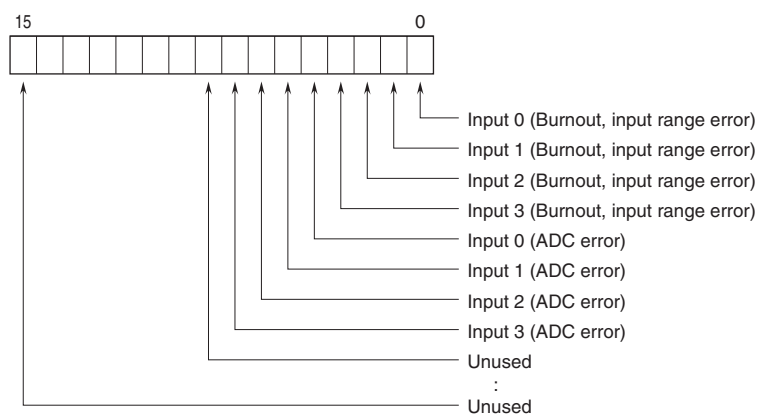

Burnout, input range error ($\leq -15\%$, $\geq +115\%$)

0 : Normal 1 : Error

ADC error (no response from ADC)

0 : Normal 1 : Error



DATA CONVERSION

■ 0 – 100% DATA CONVERSION

Analog input data is converted into digital representations of 0 – 100% proportional to each scaled range. The converted % values are multiplied by 100 and expressed in 16 bits.

Overrange input is possible from -15 to +115% of the nominal range. When the signal exceeds the limit, the data is fixed at -15% or +115% respectively. Negative value is represented in 2's complements.

• Input Range 0 – 5 V DC

| Input Value | Input % | Converted Data, Decimal | Converted Data, Hex |
|-------------|---------|-------------------------|---------------------|
| ≤ -0.75 V | -15% | -1500 | FA24 |
| 0 V | 0% | 0 | 0 |
| 5 V | 100% | 10000 | 2710 |
| ≥ 5.75 V | 115% | 11500 | 2CEC |

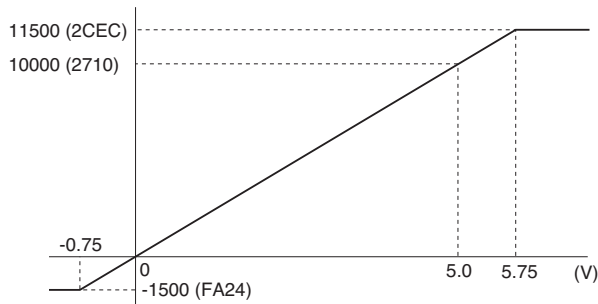

Analog output is converted in the reverse order of the input data. The output range 0 – 5 V DC is expressed as 10000 at 5.0 V (100%) and 0 at 0 V (0%).

■ ENGINEERING UNIT CONVERSION

Engineering unit value °C or K is multiplied by 10 and expressed in 16 bits. °F data is represented in engineering unit value, without multiplication. Engineering unit value A is multiplied by 100 or 1000, expressed in 16 bits. Negative value is represented in 2's complements.

• Input TYPE K Thermocouple

| Input Value | Converted Data, Decimal | Converted Data, Hex |
|-------------|-------------------------|---------------------|
| ≤ -272°C | -2720 | F560 |
| -150°C | -1500 | FA24 |
| 1370°C | 13700 | 3584 |
| ≥ 1472°C | 14720 | 3980 |

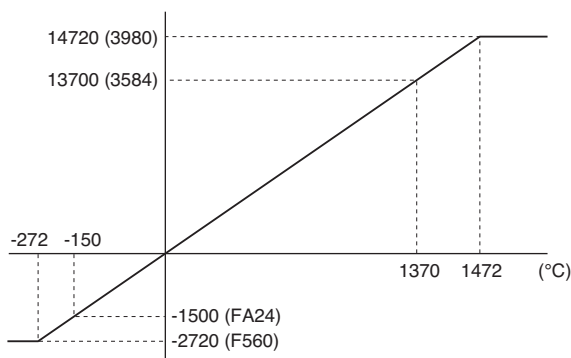

■ COUNT VALUE

The count value is 32-bit data. It is divided in 2 words of 16 bits represented with 2 addresses. The lower address is allocated in the upper word (MSB) and the upper address in the lower word (LSB). The count value is 0 - 4 294 967 295. The maximum count value available is 1 000 - 4 294 967 295. In case of overflow, the value is reset to 0 or 1 (configurable) from which the count will restart. The preset of the count value is also available. Use the R7CON or commands for the configuration.



EXTENSION MODULE

A 'basic' module can be attached with one 'extension' module. The extension module is powered from the basic module. By combining two modules, single station can handle mixed analog and discrete signals, 32-point discrete inputs, 32-point discrete outputs, 16-point discrete I/Os and other combinations of signals.

Note: Relay contact 8 points output module can not be attached with an 'Extension' module.

■ OUTPUT AT THE LOSS OF COMMUNICATION

The extension module is set to 'Hold Output' by factory default setting. The PC Configurator is used to change the setting to 'Reset Output.'

■ CONNECTING THE EXTENSION MODULE

- 1) Remove the extension connector cover located at the side of the basic module.
- 2) Connect the extension module.

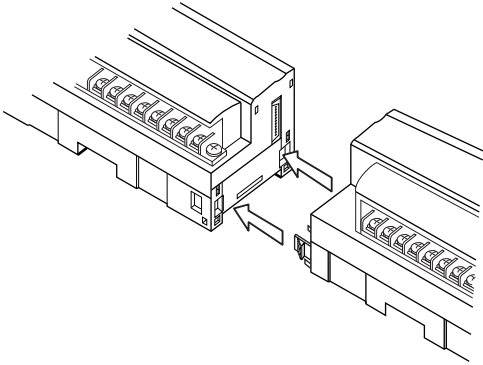

- 3) Mount the combined module on a DIN rail.



DIMENSIONS unit: mm (inch)

■ BASIC MODULE

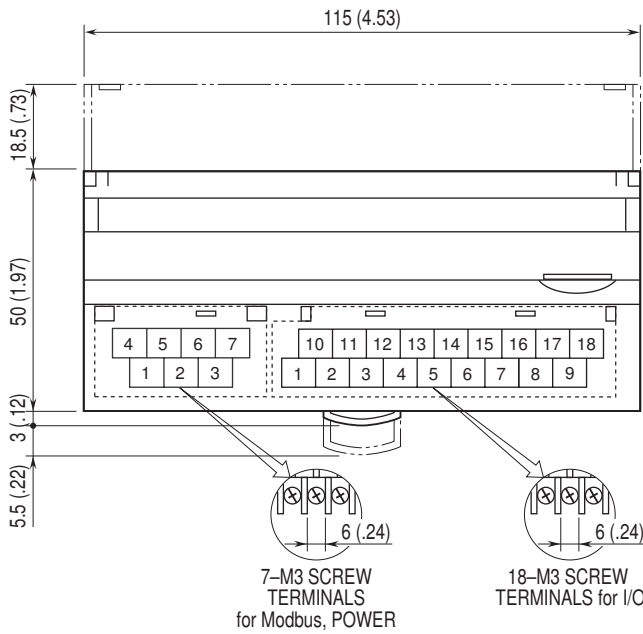

• R7M-TS4

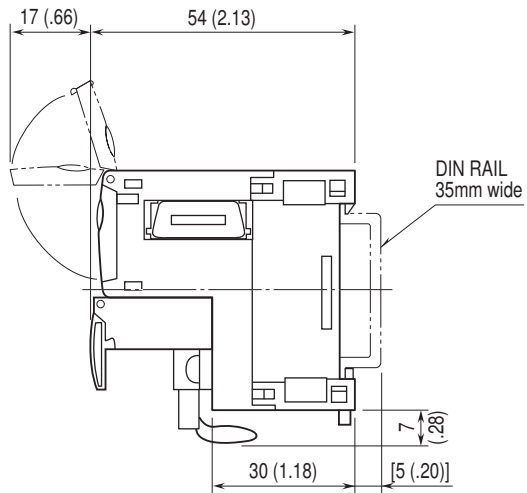

■ ANALOG OUTPUT

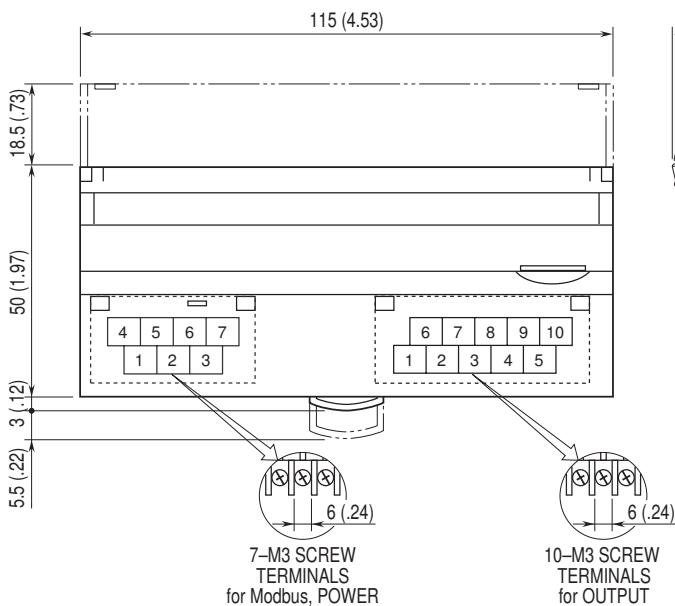

■ EXTENSION MODULE, 8 POINTS

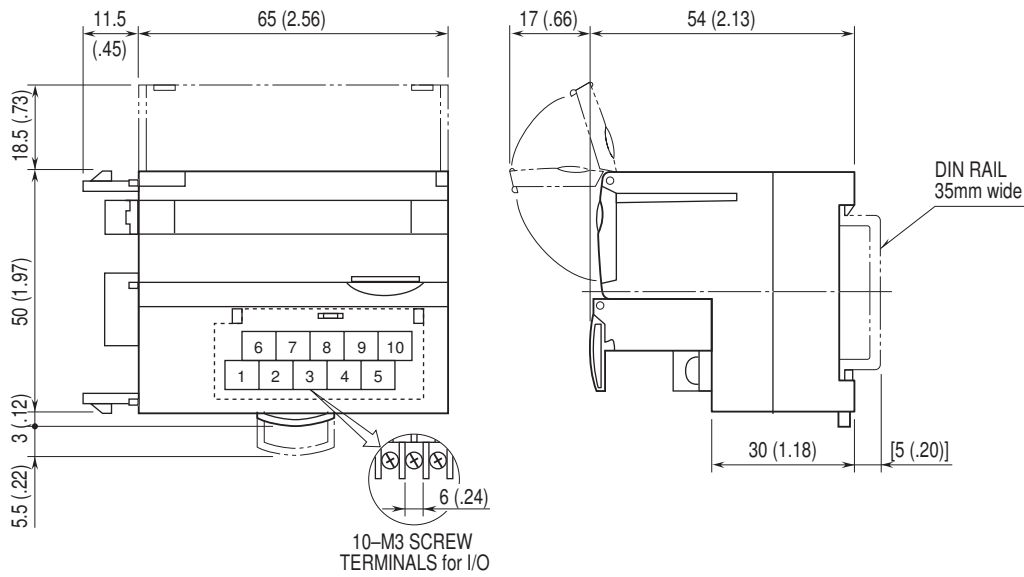

■ EXTENSION MODULE, 16 POINTS

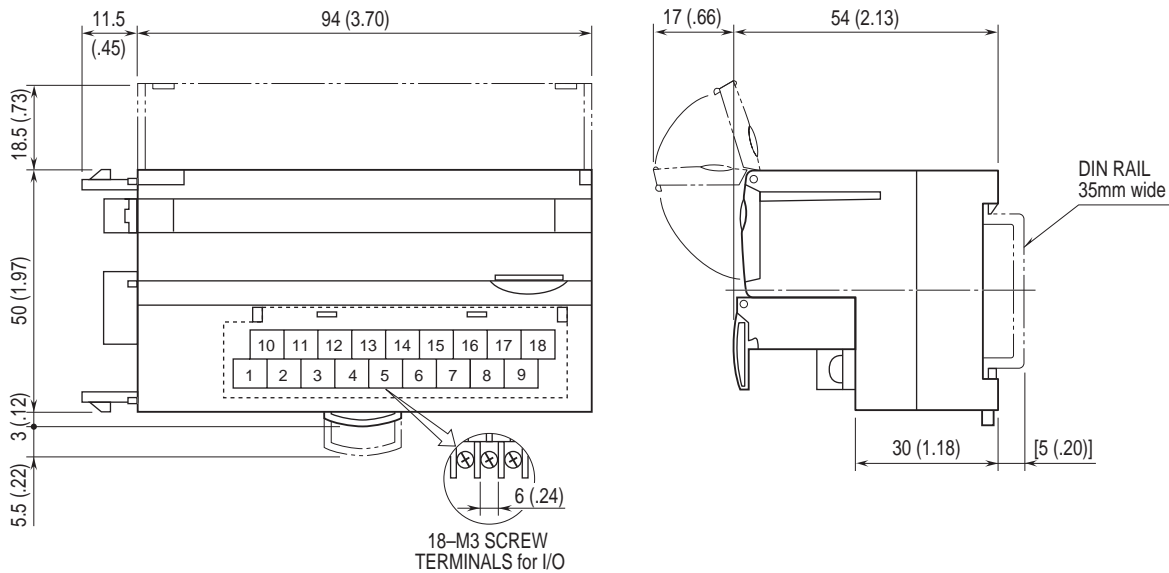

DISCRETE INPUT MODULE, 16 points

MODEL: R7M-DA16

SPECIFICATIONS

- Common:** Positive or negative common (PNP/NPN) per 16 points
- Number of I/O:** Input, 16 points
- Maximum inputs applicable at once:** No limit (at 24 V DC)
- Input status indicator LED:** Turns ON with contact ON
- Isolation:** Input to Modbus or FG to power input
- Rated input voltage:** 24 V DC $\pm 10\%$; ripple 5 %p-p max.
- ON voltage / current:** ≥ 15 V DC (input - COM) / ≥ 3.5 mA
- OFF voltage / current:** ≤ 5 V DC (input - COM) / ≤ 1 mA
- Input current:** ≤ 5.5 mA per point at 24 V DC
- Input resistance:** Approx. 4.4 k Ω
- ON delay:** ≤ 2.0 msec.
- OFF delay:** ≤ 2.0 msec.

OPERATING MODE SETTING

(*) Factory setting

Caution ! - SW1-3 through 1-8 are unused. Be sure to turn off unused ones.

• Extension (SW1-1, 1-2)

| SW1-1 | SW1-2 | EXTENSION |
|-------|-------|---------------------------------|
| OFF | OFF | No extension (*) |
| ON | OFF | Discrete input, 8 or 16 points |
| OFF | ON | Discrete output, 8 or 16 points |

TERMINAL ASSIGNMENTS

| | | | | | | | | |
|-----|----|----|----|----|----|----|----|----|
| 10 | 11 | 12 | 13 | 14 | 15 | 16 | 17 | 18 |
| COM | X1 | X3 | X5 | X7 | X9 | XB | XD | XF |
| 1 | 2 | 3 | 4 | 5 | 6 | 7 | 8 | 9 |
| COM | X0 | X2 | X4 | X6 | X8 | XA | XC | XE |

| NO. | ID | FUNCTION | NO. | ID | FUNCTION |
|-----|-----|----------|-----|-----|----------|
| 1 | COM | Common | 10 | COM | Common |
| 2 | X0 | Input 0 | 11 | X1 | Input 1 |
| 3 | X2 | Input 2 | 12 | X3 | Input 3 |
| 4 | X4 | Input 4 | 13 | X5 | Input 5 |
| 5 | X6 | Input 6 | 14 | X7 | Input 7 |
| 6 | X8 | Input 8 | 15 | X9 | Input 9 |
| 7 | XA | Input 10 | 16 | XB | Input 11 |
| 8 | XC | Input 12 | 17 | XD | Input 13 |
| 9 | XE | Input 14 | 18 | XF | Input 15 |

CIRCUIT DIAGRAM

Note: In order to improve EMC performance, bond the FG terminal to ground.

Caution: FG terminal is NOT a protective conductor terminal.

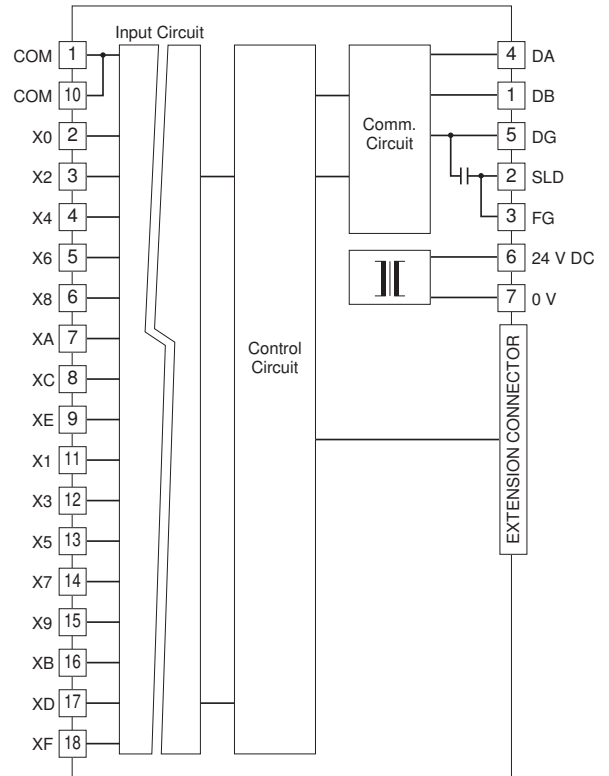

Input Circuit

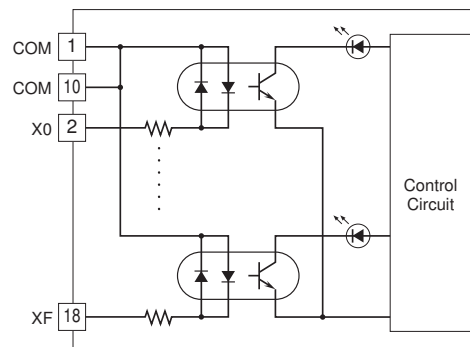

Input Connection Examples

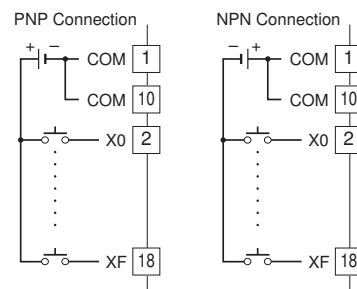

DISCRETE INPUT MODULE, 16 points

(115.2 kbps)

MODEL: R7M-DA16F

SPECIFICATIONS

Common: Positive or negative common (NPN/PNP) per 16 points

Number of I/O: Input, 16 points

Maximum inputs applicable at once: No limit (at 24 V DC)

Input status indicator LED: Turns ON with contact ON

Isolation: Input to Modbus or FG to power input

Rated input voltage: 24 V DC $\pm 10\%$; ripple 5 %p-p max.

ON voltage / current: ≥ 15 V DC (input - COM) / ≥ 3.5 mA

OFF voltage / current: ≤ 5 V DC (input - COM) / ≤ 1 mA

Input current: ≤ 5.5 mA per point at 24 V DC

Input resistance: Approx. 4.4 k Ω

ON delay: ≤ 0.5 msec.

OFF delay: ≤ 1.0 msec.

OPERATING MODE SETTING

(*) Factory setting

Caution ! - SW1-3 through 1-8 are unused. Be sure to turn off unused ones.

• Extension (SW1-1, 1-2)

| SW1-1 | SW1-2 | EXTENSION |
|-------|-------|---------------------------------|
| OFF | OFF | No extension (*) |
| ON | OFF | Discrete input, 8 or 16 points |
| OFF | ON | Discrete output, 8 or 16 points |

TERMINAL ASSIGNMENTS

| | | | | | | | | |
|-----|----|----|----|----|----|----|----|----|
| 10 | 11 | 12 | 13 | 14 | 15 | 16 | 17 | 18 |
| COM | X1 | X3 | X5 | X7 | X9 | XB | XD | XF |
| 1 | 2 | 3 | 4 | 5 | 6 | 7 | 8 | 9 |
| COM | X0 | X2 | X4 | X6 | X8 | XA | XC | XE |

| NO. | ID | FUNCTION | NO. | ID | FUNCTION |
|-----|-----|----------|-----|-----|----------|
| 1 | COM | Common | 10 | COM | Common |
| 2 | X0 | Input 0 | 11 | X1 | Input 1 |
| 3 | X2 | Input 2 | 12 | X3 | Input 3 |
| 4 | X4 | Input 4 | 13 | X5 | Input 5 |
| 5 | X6 | Input 6 | 14 | X7 | Input 7 |
| 6 | X8 | Input 8 | 15 | X9 | Input 9 |
| 7 | XA | Input 10 | 16 | XB | Input 11 |
| 8 | XC | Input 12 | 17 | XD | Input 13 |
| 9 | XE | Input 14 | 18 | XF | Input 15 |

CIRCUIT DIAGRAM

Note: In order to improve EMC performance, bond the FG terminal to ground.

Caution: FG terminal is NOT a protective conductor terminal.

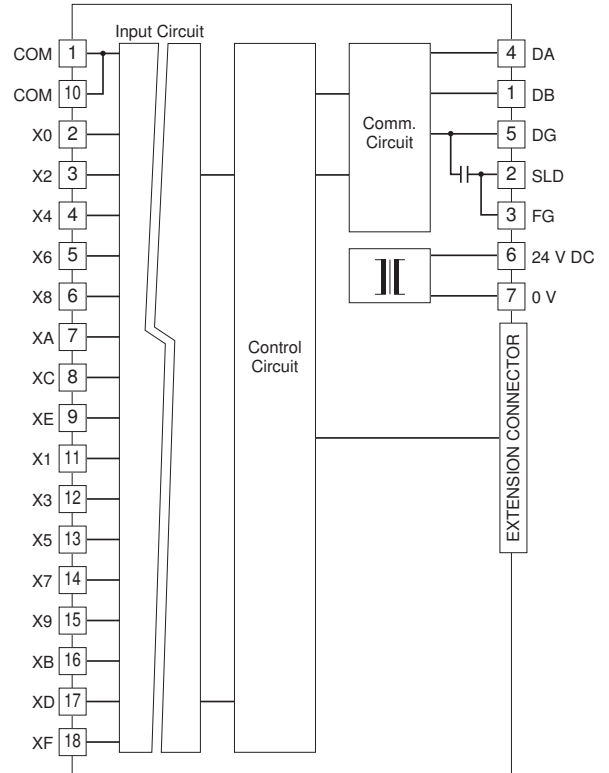

Input Circuit

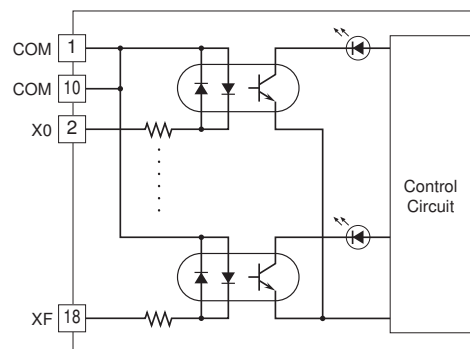

Input Connection Examples

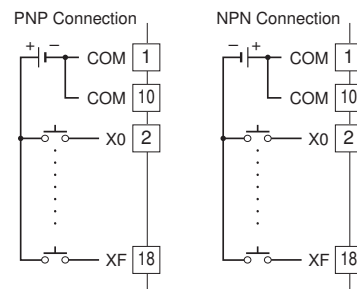

NPN TRANSISTOR OUTPUT MODULE, 16 points

MODEL: R7M-DC16A

SPECIFICATIONS

- Common:** Negative common (NPN) per 16 points
- Number of I/O:** Output, 16 points
- Maximum outputs applicable at once:** No limit (at 24 V DC)
- Output status indicator:** LED turns ON with contact ON
- Isolation:** Output to Modbus or FG to power input
- Rated load voltage:** 24 V DC $\pm 10\%$
- Rated output current:** 0.25 A per point, 2.0 A per common
- Residual voltage:** ≤ 1.2 V
- Leakage current:** ≤ 0.1 mA
- ON delay:** ≤ 0.5 msec.
- OFF delay:** ≤ 1.5 msec.

OPERATING MODE SETTING

(*) Factory setting

Caution ! - SW1-3, 1-5 through 1-8 are unused. Be sure to turn off unused ones.

• Output at the loss of communication (SW1-4)

| SW1-4 | OUTPUT AT THE LOSS OF COMMUNICATION |
|-------|--|
| OFF | Reset the output (turned off) |
| ON | Hold the output (*) (maintains the last data received normally) |

• Extension (SW1-1, 1-2)

| SW1-1 | SW1-2 | EXTENSION |
|-------|-------|---------------------------------|
| OFF | OFF | No extension (*) |
| ON | OFF | Discrete input, 8 or 16 points |
| OFF | ON | Discrete output, 8 or 16 points |

TERMINAL ASSIGNMENTS

| | | | | | | | | |
|-------|----|----|----|----|----|----|----|----|
| 10 | 11 | 12 | 13 | 14 | 15 | 16 | 17 | 18 |
| +24 V | Y1 | Y3 | Y5 | Y7 | Y9 | YB | YD | YF |
| 1 | 2 | 3 | 4 | 5 | 6 | 7 | 8 | 9 |
| 0 V | Y0 | Y2 | Y4 | Y6 | Y8 | YA | YC | YE |

| NO. | ID | FUNCTION | NO. | ID | FUNCTION |
|-----|-----|--------------|-----|-------|-----------|
| 1 | 0 V | 0 V (common) | 10 | +24 V | 24 V DC |
| 2 | Y0 | Output 0 | 11 | Y1 | Output 1 |
| 3 | Y2 | Output 2 | 12 | Y3 | Output 3 |
| 4 | Y4 | Output 4 | 13 | Y5 | Output 5 |
| 5 | Y6 | Output 6 | 14 | Y7 | Output 7 |
| 6 | Y8 | Output 8 | 15 | Y9 | Output 9 |
| 7 | YA | Output 10 | 16 | YB | Output 11 |
| 8 | YC | Output 12 | 17 | YD | Output 13 |
| 9 | YE | Output 14 | 18 | YF | Output 15 |

CIRCUIT DIAGRAM

Note: In order to improve EMC performance, bond the FG terminal to ground.

Caution: FG terminal is NOT a protective conductor terminal.

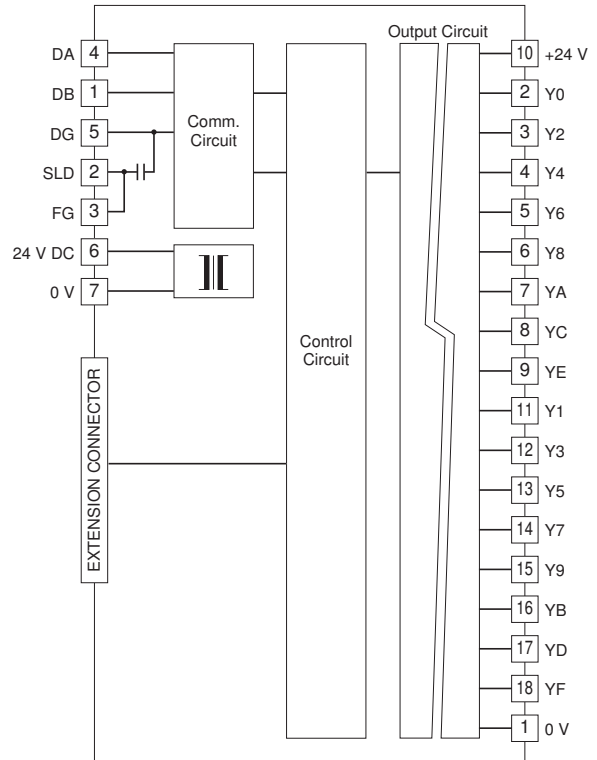

Output Circuit

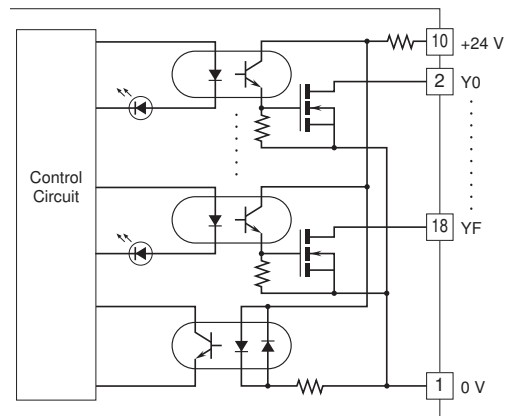

Output Connection Example

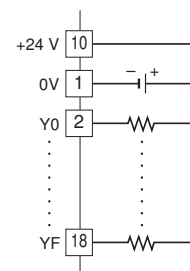

PNP TRANSISTOR OUTPUT MODULE, 16 points

MODEL: R7M-DC16B

SPECIFICATIONS

- Common:** Positive common (PNP) per 16 points
- Number of I/O:** Output, 16 points
- Maximum outputs applicable at once:** No limit (at 24 V DC)
- Output status indicator:** LED turns ON with contact ON
- Isolation:** Output to Modbus or FG to power input
- Rated load voltage:** 24 V DC $\pm 10\%$
- Rated output current:** 0.25 A per point, 2.0 A per common
- Residual voltage:** ≤ 1.2 V
- Leakage current:** ≤ 0.1 mA
- ON delay:** ≤ 0.5 msec.
- OFF delay:** ≤ 1.5 msec.

OPERATING MODE SETTING

(*) Factory setting

Caution ! - SW1-3, 1-5 through 1-8 are unused. Be sure to turn off unused ones.

• Output at the loss of communication (SW1-4)

| | | |
|-------|--|--|
| SW1-4 | OUTPUT AT THE LOSS OF COMMUNICATION | |
| OFF | Reset the output (turned off) | |
| ON | Hold the output (*) (maintains the last data received normally) | |

• Extension (SW1-1, 1-2)

| | | |
|-------|-------|---------------------------------|
| SW1-1 | SW1-2 | EXTENSION |
| OFF | OFF | No extension (*) |
| ON | OFF | Discrete input, 8 or 16 points |
| OFF | ON | Discrete output, 8 or 16 points |

TERMINAL ASSIGNMENTS

| | | | | | | | | |
|-------|----|----|----|----|----|----|----|----|
| 10 | 11 | 12 | 13 | 14 | 15 | 16 | 17 | 18 |
| +24 V | Y1 | Y3 | Y5 | Y7 | Y9 | YB | YD | YF |
| 1 | 2 | 3 | 4 | 5 | 6 | 7 | 8 | 9 |
| 0 V | Y0 | Y2 | Y4 | Y6 | Y8 | YA | YC | YE |

| NO. | ID | FUNCTION | NO. | ID | FUNCTION |
|-----|-----|-----------|-----|-------|------------------|
| 1 | 0 V | 0 V | 10 | +24 V | 24 V DC (common) |
| 2 | Y0 | Output 0 | 11 | Y1 | Output 1 |
| 3 | Y2 | Output 2 | 12 | Y3 | Output 3 |
| 4 | Y4 | Output 4 | 13 | Y5 | Output 5 |
| 5 | Y6 | Output 6 | 14 | Y7 | Output 7 |
| 6 | Y8 | Output 8 | 15 | Y9 | Output 9 |
| 7 | YA | Output 10 | 16 | YB | Output 11 |
| 8 | YC | Output 12 | 17 | YD | Output 13 |
| 9 | YE | Output 14 | 18 | YF | Output 15 |

CIRCUIT DIAGRAM

Note: In order to improve EMC performance, bond the FG terminal to ground.

Caution: FG terminal is NOT a protective conductor terminal.

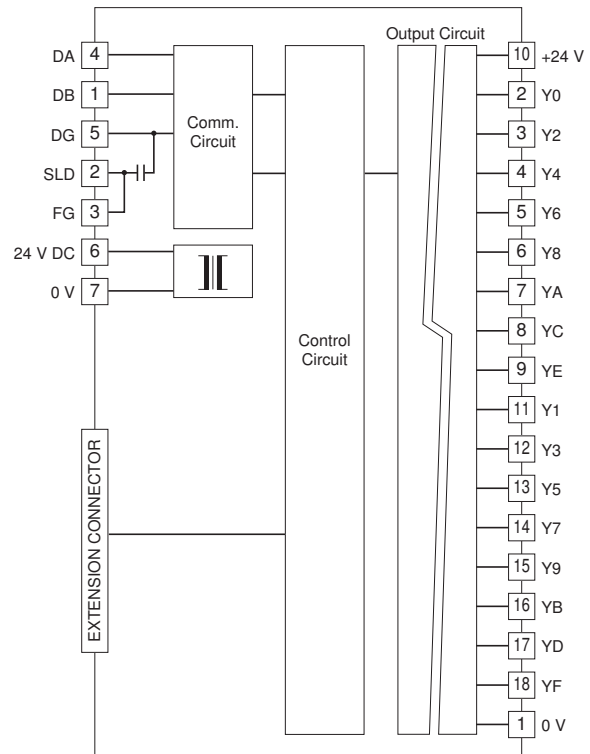

Output Circuit

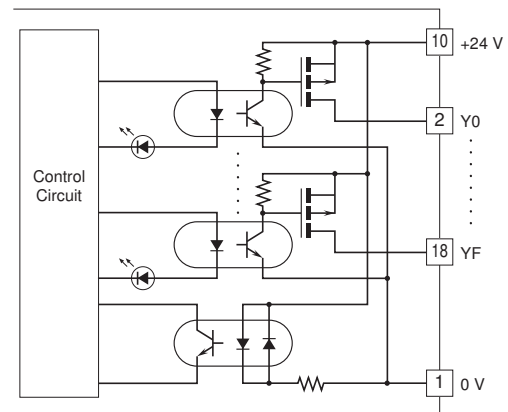

Output Connection Example

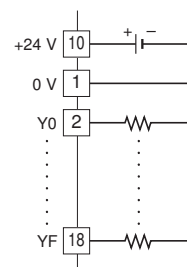

NPN DISCRETE INPUT & NPN TRANSISTOR OUTPUT MODULE, 8 points each (115.2 kbps)

MODEL: R7M-DAC16C

SPECIFICATIONS

COMMON SPECIFICATIONS

Input common: Positive common per 8 points
Output common: Negative common per 8 points
Number of I/O: Input, 8 points; Output, 8 points
Maximum I/O applicable at once: No limit (at 24 V DC)
I/O status indicator LED: Turns ON with contact ON
Isolation: I/O to power input to Modbus or FG

INPUT

Rated input voltage: 24 V DC $\pm 10\%$; ripple 5 %p-p max.
ON voltage/current: ≥ 15 V DC (input-C+) / ≥ 3.5 mA
OFF voltage/current: ≤ 5 V DC (input-C+) / ≤ 1 mA
Input current: ≤ 5.5 mA per point at 24 V DC
Input resistance: Approx. 4.4 k Ω
ON delay: ≤ 0.5 msec.
OFF delay: ≤ 1.0 msec.

OUTPUT

Rated load voltage: 24 V DC $\pm 10\%$
Rated output current: 0.1 A per point, 0.8 A per common
Residual voltage: ≤ 1.2 V
Leakage current: ≤ 0.1 mA
ON delay: ≤ 0.5 msec.
OFF delay: ≤ 1.0 msec.
Overload current protection function: Limits the current value when overcurrent is detected
Overheat Protection Function: Turns OFF the output when overheat is detected

OPERATING MODE SETTING

(*) Factory setting

Extension (SW1-1, 1-2)

| SW1-1 | SW1-2 | EXTENSION |
|-------|-------|---------------------------------|
| OFF | OFF | No extension (*) |
| ON | OFF | Discrete input, 8 or 16 points |
| OFF | ON | Discrete output, 8 or 16 points |

OUTPUT OPERATION MODE (SW1-3)

| SW1-3 | Output operation mode |
|-------|-----------------------|
| OFF | Disable (*) |
| ON | Enable |

Output switching mode can be independently selected by 2 outputs with PC Configuration software. An example of setting is given below.

Output 0: Maintained output
 Output 1: Maintained output
 Output 2: Momentary output
 Output 3: Momentary output
 Output 4: Momentary output
 Output 5: Momentary output
 Output 6: Maintained output
 Output 7: Maintained output

Output at the Loss of Communication (SW1-4)

| SW1-4 | Output at the loss of communication |
|-------|--|
| OFF | Reset the output (turned off) |
| ON | Hold the output (*) (maintains the last data received normally) |

Output Switching Mode (SW1-5)

| SW1-5 | Output switching mode |
|-------|----------------------------|
| OFF | Maintained Output Mode (*) |
| ON | Momentary Output Mode |

SW1-5 setting is disregarded when SW1-3 is set to ON.

Output ON Time (SW1-6, 1-7, 1-8)

| SW1-6 | SW1-7 | SW1-8 | ON Time |
|-------|-------|-------|------------|
| OFF | OFF | OFF | 100 ms (*) |
| ON | OFF | OFF | 200 ms |
| OFF | ON | OFF | 300 ms |
| ON | ON | OFF | 500 ms |
| OFF | OFF | ON | 1 s |
| ON | OFF | ON | 2 s |
| OFF | ON | ON | 5 s |
| ON | ON | ON | 10 s |

TERMINAL ASSIGNMENTS

| | | | | | | | | |
|----------|----------|----------|----------|----------|----------|----------|----------|----------|
| 10 C+ | 11 X1 | 12 X3 | 13 X5 | 14 X7 | 15 Y1 | 16 Y3 | 17 Y5 | 18 Y7 |
| 1 C- | 2 X0 | 3 X2 | 4 X4 | 5 X6 | 6 Y0 | 7 Y2 | 8 Y4 | 9 Y6 |

| NO. | ID | FUNCTION | NO. | ID | FUNCTION |
|-----|----|----------|-----|----|----------|
| 1 | C- | Common- | 10 | C+ | Common+ |
| 2 | X0 | Input 0 | 11 | X1 | Input 1 |
| 3 | X2 | Input 2 | 12 | X3 | Input 3 |
| 4 | X4 | Input 4 | 13 | X5 | Input 5 |
| 5 | X6 | Input 6 | 14 | X7 | Input 7 |
| 6 | Y0 | Output 0 | 15 | Y1 | Output 1 |
| 7 | Y2 | Output 2 | 16 | Y3 | Output 3 |
| 8 | Y4 | Output 4 | 17 | Y5 | Output 5 |
| 9 | Y6 | Output 6 | 18 | Y7 | Output 7 |



CIRCUIT DIAGRAM

Note: In order to improve EMC performance, bond the FG terminal to ground.

Caution: FG terminal is NOT a protective conductor terminal.

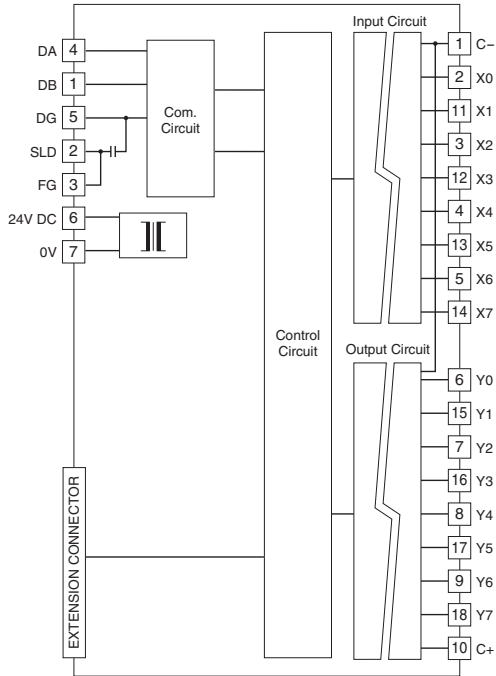

■ Input Circuit

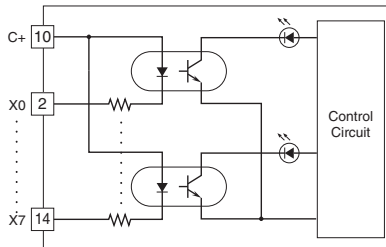

■ Output Circuit

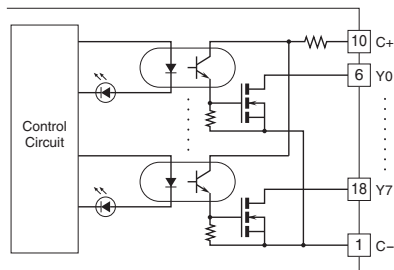

■ I/O Connection Example

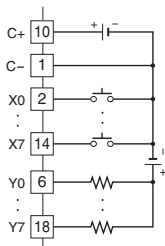

PNP DISCRETE INPUT & PNP TRANSISTOR OUTPUT MODULE, 8 points each (115.2 kbps)

MODEL: R7M-DAC16D

SPECIFICATIONS

COMMON SPECIFICATIONS

Input common: Negative common per 8 points
Output common: Positive common per 8 points
Number of I/O: Input, 8 points; Output, 8 points
Maximum I/O applicable at once: No limit (at 24 V DC)
I/O status indicator LED: Turns ON with contact ON
Isolation: I/O to power input to Modbus or FG

INPUT

Rated input voltage: 24 V DC $\pm 10\%$; ripple 5 %p-p max.
ON voltage/current: ≥ 15 V DC (input - C-) / ≥ 3.5 mA
OFF voltage/current: ≤ 5 V DC (input - C-) / ≤ 1 mA
Input current: ≤ 5.5 mA per point at 24 V DC
Input resistance: Approx. 4.4 k Ω
ON delay: ≤ 0.5 msec.
OFF delay: ≤ 1.0 msec.

OUTPUT

Rated load voltage: 24 V DC $\pm 10\%$
Rated output current: 0.1 A per point, 0.8 A per common
Residual voltage: ≤ 1.2 V
Leakage current: ≤ 0.1 mA
ON delay: ≤ 0.5 msec.
OFF delay: ≤ 1.0 msec.
Overload current protection function: Limits the current value when overcurrent is detected
Overheat Protection Function: Turns OFF the output when overheat is detected

OPERATING MODE SETTING

(*) Factory setting

Extension (SW1-1, 1-2)

| SW1-1 | SW1-2 | EXTENSION |
|-------|-------|---------------------------------|
| OFF | OFF | No extension (*) |
| ON | OFF | Discrete input, 8 or 16 points |
| OFF | ON | Discrete output, 8 or 16 points |

OUTPUT OPERATION MODE (SW1-3)

| SW1-3 | Output operation mode |
|-------|-----------------------|
| OFF | Disable (*) |
| ON | Enable |

Output switching mode can be independently selected by 2 outputs with PC Configuration software. An example of setting is given below.

Output 0: Maintained output
 Output 1: Maintained output
 Output 2: Momentary output
 Output 3: Momentary output
 Output 4: Momentary output
 Output 5: Momentary output
 Output 6: Maintained output
 Output 7: Maintained output

Output at the Loss of Communication (SW1-4)

| SW1-4 | Output at the loss of communication |
|-------|--|
| OFF | Reset the output (turned off) |
| ON | Hold the output (*) (maintains the last data received normally) |

Output Switching Mode (SW1-5)

| SW1-5 | Output switching mode |
|-------|----------------------------|
| OFF | Maintained Output Mode (*) |
| ON | Momentary Output Mode |

SW1-5 setting is disregarded when SW1-3 is set to ON.

Output ON Time (SW1-6, 1-7, 1-8)

| SW1-6 | SW1-7 | SW1-8 | ON Time |
|-------|-------|-------|------------|
| OFF | OFF | OFF | 100 ms (*) |
| ON | OFF | OFF | 200 ms |
| OFF | ON | OFF | 300 ms |
| ON | ON | OFF | 500 ms |
| OFF | OFF | ON | 1 s |
| ON | OFF | ON | 2 s |
| OFF | ON | ON | 5 s |
| ON | ON | ON | 10 s |

TERMINAL ASSIGNMENTS

| | | | | | | | | |
|----|----|----|----|----|----|----|----|----|
| 10 | 11 | 12 | 13 | 14 | 15 | 16 | 17 | 18 |
| C+ | X1 | X3 | X5 | X7 | Y1 | Y3 | Y5 | Y7 |
| 1 | 2 | 3 | 4 | 5 | 6 | 7 | 8 | 9 |
| C- | X0 | X2 | X4 | X6 | Y0 | Y2 | Y4 | Y6 |

| NO. | ID | FUNCTION | NO. | ID | FUNCTION |
|-----|----|----------|-----|----|----------|
| 1 | C- | Common- | 10 | C+ | Common+ |
| 2 | X0 | Input 0 | 11 | X1 | Input 1 |
| 3 | X2 | Input 2 | 12 | X3 | Input 3 |
| 4 | X4 | Input 4 | 13 | X5 | Input 5 |
| 5 | X6 | Input 6 | 14 | X7 | Input 7 |
| 6 | Y0 | Output 0 | 15 | Y1 | Output 1 |
| 7 | Y2 | Output 2 | 16 | Y3 | Output 3 |
| 8 | Y4 | Output 4 | 17 | Y5 | Output 5 |
| 9 | Y6 | Output 6 | 18 | Y7 | Output 7 |



CIRCUIT DIAGRAM

Note: In order to improve EMC performance, bond the FG terminal to ground.

Caution: FG terminal is NOT a protective conductor terminal.

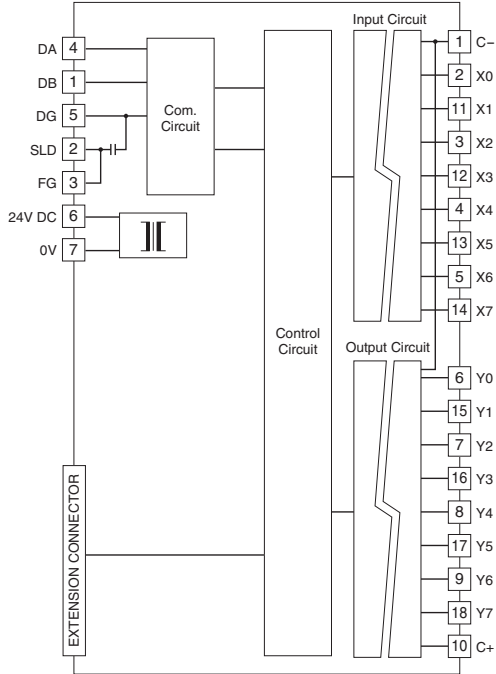

■ Input Circuit

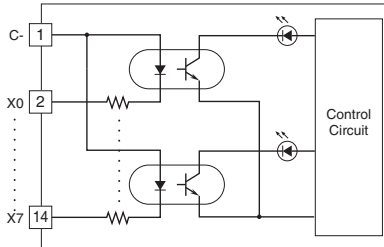

■ Output Circuit

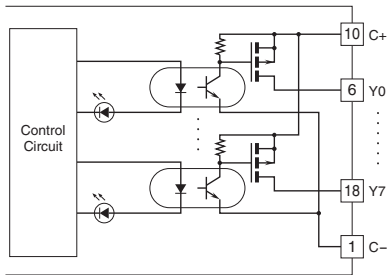

■ I/O Connection Example

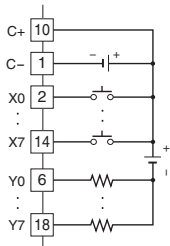

RELAY CONTACT OUTPUT MODULE, 8 points

MODEL: R7M-DC8C

SPECIFICATIONS

Common: 1 common per 4 points (4 terminals)
Maximum current load: 2.0 A per point
Common current: Max. 8 A (4 terminals)
Number of I/O: Relay contact output, 8 points
Maximum outputs applicable at once: No limit (at 24 V DC)
Output status indicator: LED turns ON with contact ON
Isolation: Output to Modbus or FG to power input
Relay driving power: 24 V DC $\pm 10\%$, ≥ 60 mA
Rated load: 250 V AC @ 2 A ($\cos \phi = 1$)
 30 V DC @ 2 A (resistive load)
 (When it is used as a product relevant to EC directive, it should be used under the Installation Category I, 125 V AC or less.)
Maximum switching voltage: 250 V AC or 30 V DC
Maximum switching power: 500 VA or 60 W
Minimum load: 24 V DC @ 5 mA
Mechanical life: 2×10^7 cycles (rate 300/min.)
 When driving an inductive load, external contact protection and noise quenching are recommended.
ON delay: ≤ 10 msec.
OFF delay: ≤ 10 msec.

CIRCUIT DIAGRAM

Note: In order to improve EMC performance, bond the FG terminal to ground.

Caution: FG terminal is NOT a protective conductor terminal.

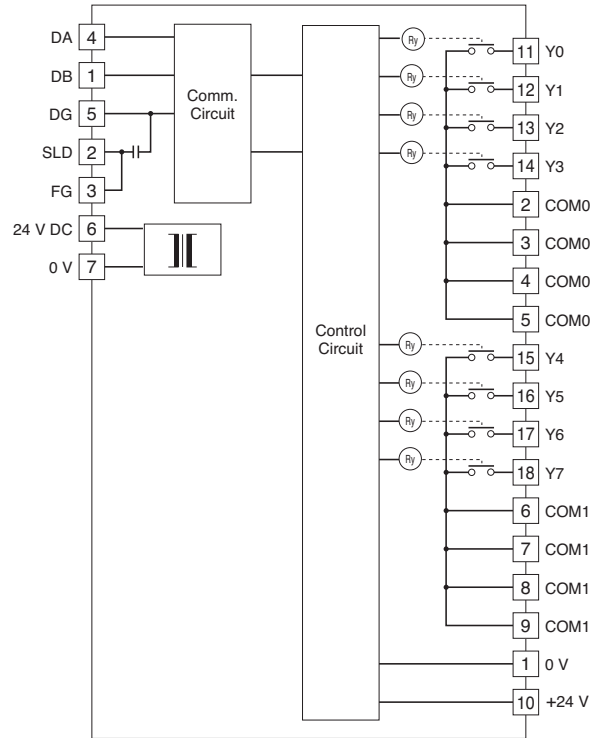

OPERATING MODE SETTING

(*) Factory setting

Caution ! - SW1-1 through 1-3, 1-5 through 1-8 are unused.
 Be sure to turn off the unused ones.

• Output at the loss of communication (SW1-4)

| SW1-4 | OUTPUT AT THE LOSS OF COMMUNICATION |
|-------|--|
| OFF | Reset the output (turned off) |
| ON | Hold the output (*) (maintains the last data received normally) |

TERMINAL ASSIGNMENTS

| | | | | | | | | |
|-------|------|------|------|------|------|------|------|------|
| 10 | 11 | 12 | 13 | 14 | 15 | 16 | 17 | 18 |
| +24 V | Y0 | Y1 | Y2 | Y3 | Y4 | Y5 | Y6 | Y7 |
| 1 | 2 | 3 | 4 | 5 | 6 | 7 | 8 | 9 |
| 0 V | COM0 | COM0 | COM0 | COM0 | COM1 | COM1 | COM1 | COM1 |

| NO. | ID | FUNCTION | NO. | ID | FUNCTION |
|-----|------|----------|-----|-------|----------|
| 1 | 0 V | 0 V | 10 | +24 V | 24 V DC |
| 2 | COM0 | Common 0 | 11 | Y0 | Output 0 |
| 3 | COM0 | Common 0 | 12 | Y1 | Output 1 |
| 4 | COM0 | Common 0 | 13 | Y2 | Output 2 |
| 5 | COM0 | Common 0 | 14 | Y3 | Output 3 |
| 6 | COM1 | Common 1 | 15 | Y4 | Output 4 |
| 7 | COM1 | Common 1 | 16 | Y5 | Output 5 |
| 8 | COM1 | Common 1 | 17 | Y6 | Output 6 |
| 9 | COM1 | Common 1 | 18 | Y7 | Output 7 |

Output Connection Example

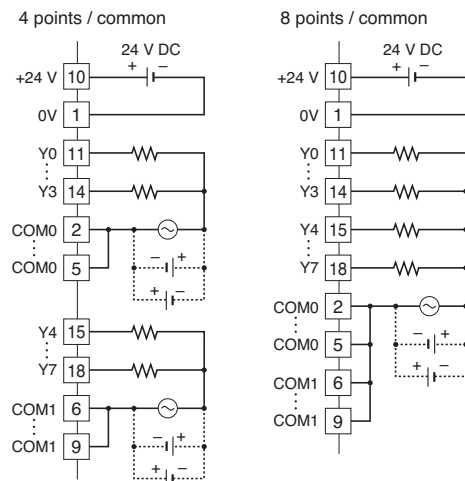

REMOTE CONTROL RELAY CONTROL MODULE, 8 points
(115.2 kbps)

MODEL: R7M-RR8

SPECIFICATIONS

- Common:** Common per all points
- Number of I/O:** Output, 8 points
- Maximum outputs applicable at once:** No limit
- I/O status indicator:** Feedback input status turns on with the input supplied.
- Output status turns on with the output ON.
- Isolation:** Output to power input to Modbus or FG
- Pulse output time:** 100 msec.
- Rated load voltage:** 24 V AC $\pm 10\%$ (supplied by the remote control transformer)
- Load voltage frequency:** 50 / 60 Hz

OPERATING MODE SETTING

- (*) Factory setting
 - Caution ! - SW1-3 through 1-8 are unused. Be sure to turn off unused ones.
 - **Extension (SW1-1, 1-2)**
- | SW1-1 | SW1-2 | EXTENSION |
|-------|-------|---------------------------------|
| OFF | OFF | No extension (*) |
| ON | OFF | Discrete input, 8 or 16 points |
| OFF | ON | Discrete output, 8 or 16 points |

TERMINAL ASSIGNMENTS

| 10 | 11 | 12 | 13 | 14 | 15 | 16 | 17 | 18 |
|----|----|----|----|----|----|----|----|----|
| NC | Y0 | Y1 | Y2 | Y3 | Y4 | Y5 | Y6 | Y7 |
| 1 | 2 | 3 | 4 | 5 | 6 | 7 | 8 | 9 |
| NC | C0 | C1 | C2 | C3 | C4 | C5 | C6 | C7 |

| NO. | ID | FUNCTION | NO. | ID | FUNCTION |
|-----|----|---------------|-----|----|---------------|
| 1 | NC | No connection | 10 | NC | No connection |
| 2 | C0 | Common | 11 | Y0 | Output 0 |
| 3 | C1 | Common | 12 | Y1 | Output 1 |
| 4 | C2 | Common | 13 | Y2 | Output 2 |
| 5 | C3 | Common | 14 | Y3 | Output 3 |
| 6 | C4 | Common | 15 | Y4 | Output 4 |
| 7 | C5 | Common | 16 | Y5 | Output 5 |
| 8 | C6 | Common | 17 | Y6 | Output 6 |
| 9 | C7 | Common | 18 | Y7 | Output 7 |

CIRCUIT DIAGRAM

Caution: FG terminal is NOT a protective conductor terminal.

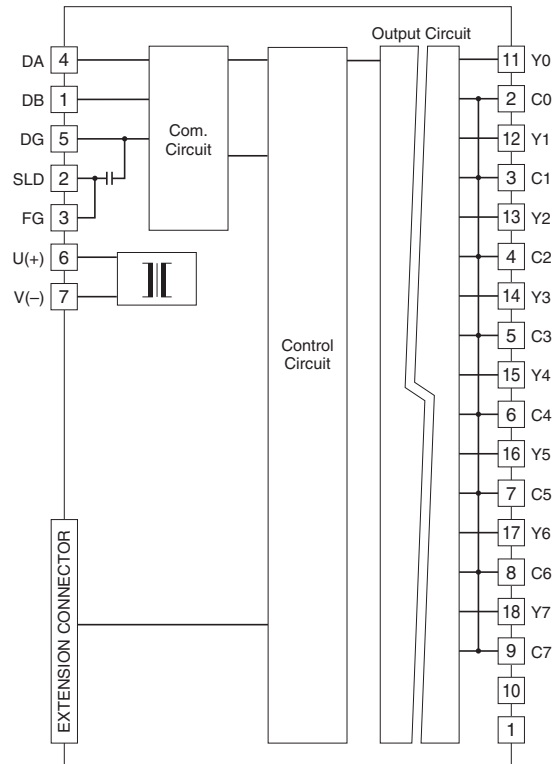

Output Connection Example

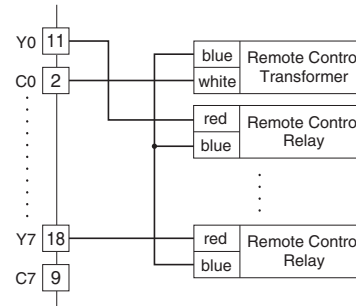

DC VOLTAGE/CURRENT INPUT MODULE, 4 points

MODEL: R7M-SV4

SPECIFICATIONS

Isolation: Input 0 to input 1 to input 2 to input 3 to Modbus or FG to power input

Converted data range: 0 - 10000 of the input range

• **Input range**

Wide span voltage: -10 - +10 V DC, -5 - +5 V DC, 0 - 10 V DC, 0 - 5 V DC, 1 - 5 V DC

Narrow span voltage: -1 - +1 V DC, 0 - 1 V DC, -0.5 - +0.5 V DC

Current range: -20 - +20 mA DC, 0 - 20 mA DC, 4 - 20 mA DC

• **Input resistance**

Wide span voltage: $\geq 1 \text{ M}\Omega$

Narrow span voltage: $\geq 100 \text{ k}\Omega$

Current range: 70Ω

Conversion rate / conversion accuracy:

10 msec./ $\pm 0.8 \%$, 20 msec./ $\pm 0.4 \%$, 40 msec./ $\pm 0.2 \%$, 80 msec./ $\pm 0.1 \%$

Response time: Conversion rate $\times 2 + 50$ msec. (0 - 90 %)

Temperature coefficient: $\pm 0.015 \%/^{\circ}\text{C}$ ($\pm 0.008 \%/^{\circ}\text{F}$)

OPERATING MODE SETTING

(*) Factory setting

• **Input range (SW1-5, 1-6, 1-7, 1-8)**

| SW1-5 | SW1-6 | SW1-7 | SW1-8 | INPUT RANGE |
|-------|-------|-------|-------|-------------------------|
| OFF | OFF | OFF | OFF | -10 - +10 V DC (*) |
| ON | OFF | OFF | OFF | -5 - +5 V DC |
| OFF | ON | OFF | OFF | -1 - +1 V DC |
| ON | ON | OFF | OFF | 0 - 10 V DC |
| OFF | OFF | ON | OFF | 0 - 5 V DC |
| ON | OFF | ON | OFF | 1 - 5 V DC |
| OFF | ON | ON | OFF | 0 - 1V DC |
| ON | ON | ON | OFF | -0.5 - +0.5 V DC |
| ON | OFF | OFF | ON | -20 - +20 mA DC |
| OFF | ON | OFF | ON | 4 - 20 mA DC |
| ON | ON | OFF | ON | 0 - 20 mA DC |
| ON | ON | ON | ON | PC Configurator setting |

• **Conversion rate / Accuracy (SW1-3, 1-4)**

| SW1-3 | SW1-4 | CONVERSION RATE / ACCURACY |
|-------|-------|-----------------------------|
| OFF | OFF | 80 msec. / $\pm 0.1 \%$ (*) |
| ON | OFF | 40 msec. / $\pm 0.2 \%$ |
| OFF | ON | 20 msec. / $\pm 0.4 \%$ |
| ON | ON | 10 msec. / $\pm 0.8 \%$ |

• **Extension (SW1-1, 1-2)**

| SW1-1 | SW1-2 | EXTENSION |
|-------|-------|---------------------------------|
| OFF | OFF | No extension (*) |
| ON | OFF | Discrete input, 8 or 16 points |
| OFF | ON | Discrete output, 8 or 16 points |

TERMINAL ASSIGNMENTS

| | | | | | | | | |
|-----|------|-----|------|----|-----|------|-----|------|
| 10 | 11 | 12 | 13 | 14 | 15 | 16 | 17 | 18 |
| VL0 | I0 | VL1 | I1 | NC | VL2 | I2 | VL3 | I3 |
| 1 | 2 | 3 | 4 | 5 | 6 | 7 | 8 | 9 |
| VH0 | COM0 | VH1 | COM1 | NC | VH2 | COM2 | VH3 | COM3 |

| NO. | ID | FUNCTION | NO. | ID | FUNCTION |
|-----|------|-------------------|-----|-----|---------------------|
| 1 | VH0 | Wide span volt. 0 | 10 | VL0 | Narrow span volt. 0 |
| 2 | COM0 | Common 0 | 11 | I0 | Current range 0 |
| 3 | VH1 | Wide span volt. 1 | 12 | VL1 | Narrow span volt. 1 |
| 4 | COM1 | Common 1 | 13 | I1 | Current range 1 |
| 5 | NC | No connection | 14 | NC | No connection |
| 6 | VH2 | Wide span volt. 2 | 15 | VL2 | Narrow span volt. 2 |
| 7 | COM2 | Common 2 | 16 | I2 | Current range 2 |
| 8 | VH3 | Wide span volt. 3 | 17 | VL3 | Narrow span volt. 3 |
| 9 | COM3 | Common 3 | 18 | I3 | Current range 3 |

CIRCUIT DIAGRAM

Note: In order to improve EMC performance, bond the FG terminal to ground.

Caution: FG terminal is NOT a protective conductor terminal.

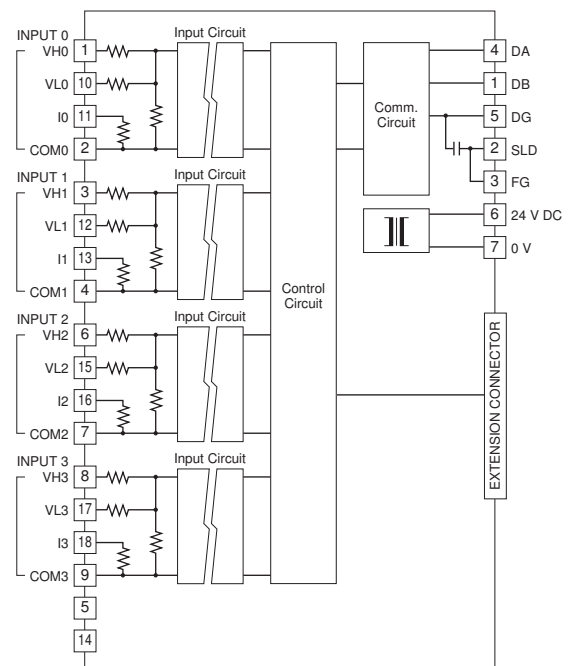

Input Connection Examples

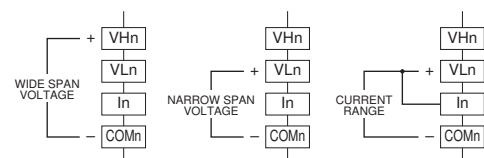

Be sure to close across VLn and In terminals for a current input.



THERMOCOUPLE INPUT MODULE, 4 points

MODEL: R7M-TS4

SPECIFICATIONS

Isolation: Input 0 to input 1 to input 2 to input 3 to Modbus or FG to power input

Converted data range: Engineering unit value (°C, K) × 10 (integer); No multiplication for °F

Thermocouple: K, E, J, T, B, R, S, C, N, U, L, P, PR

Input resistance: ≥ 30 kΩ

Burnout sensing: ≤ 0.1 μA

Conversion accuracy: ±1°C (±1.8°F);

±2.0°C (±3.6°F) for B, R, S, C, PR

Conversion rate: 250 msec. or 500 msec.

Response time: Conversion rate × 2 + 50 msec. (0 - 90 %)

Temperature coefficient: ±0.015 %/°C (±0.008 %/°F)

CJC error: ±1.0°C at 25°C ±10°C

(±1.8°F at 77°F ±18°F)

±1.5°C (±2.7°F) for R, S, PR

| T/C | BURNOUT INDICATION (°C) | | CONFORMANCE RANGE (°C) |
|-----------------|-------------------------|---------|------------------------|
| | Downscale | Upscale | |
| K (CA) | -272 | +1472 | -150 to +1370 |
| E (CRC) | -272 | +1120 | -170 to +1000 |
| J (IC) | -260 | +1300 | -180 to +1200 |
| T (CC) | -272 | + 500 | -170 to + 400 |
| B (RH) | 24 | 1920 | 400 to 1760 |
| R | -100 | +1860 | 200 to 1760 |
| S | -100 | +1860 | 0 to 1760 |
| C (WRe 5-26) | -52 | +2416 | 0 to 2315 |
| N | -272 | +1400 | -130 to +1300 |
| U | -252 | + 700 | -200 to +600 |
| L | -252 | +1000 | -200 to +900 |
| P (Platinel II) | -52 | +1496 | 0 to 1395 |
| (PR) | -52 | +1860 | 0 to 1760 |

| T/C | BURNOUT INDICATION (°F) | | CONFORMANCE RANGE (°F) |
|-----------------|-------------------------|---------|------------------------|
| | Downscale | Upscale | |
| K (CA) | -458 | +2682 | -238 to +2498 |
| E (CRC) | -458 | +2048 | -274 to +1832 |
| J (IC) | -436 | +2372 | -292 to +2192 |
| T (CC) | -458 | +932 | -274 to +752 |
| B (RH) | 75 | 3488 | 752 to 3200 |
| R | -148 | +3380 | 392 to 3200 |
| S | -148 | +3380 | 32 to 3200 |
| C (WRe 5-26) | -62 | +4381 | 32 to 4199 |
| N | -458 | +2552 | -202 to +2372 |
| U | -422 | +1292 | -328 to +1112 |
| L | -422 | +1832 | -328 to +1652 |
| P (Platinel II) | -62 | +2725 | 32 to 2543 |
| (PR) | -62 | +3380 | 32 to 3200 |

OPERATING MODE SETTING

(*) Factory setting

• Thermocouple type (SW1-5, 1-6, 1-7, 1-8)

| SW1-5 | SW1-6 | SW1-7 | SW1-8 | THERMOCOUPLE TYPE |
|-------|-------|-------|-------|-------------------------|
| OFF | OFF | OFF | OFF | K (CA) (*) |
| ON | OFF | OFF | OFF | E (CRC) |
| OFF | ON | OFF | OFF | J (IC) |
| ON | ON | OFF | OFF | T (CC) |
| OFF | OFF | ON | OFF | B (RH) |
| ON | OFF | ON | OFF | R |
| OFF | ON | ON | OFF | S |
| ON | ON | ON | OFF | C (WRe 5-26) |
| OFF | OFF | OFF | ON | N |
| ON | OFF | OFF | ON | U |
| OFF | ON | OFF | ON | L |
| ON | ON | OFF | ON | P (Platinel II) |
| OFF | OFF | ON | ON | (PR) |
| ON | ON | ON | ON | PC Configurator setting |

• Conversion rate (SW1-3)

| SW1-3 | CONVERSION RATE |
|-------|-----------------|
| OFF | 250 msec. (*) |
| ON | 500 msec. |

• Burnout (SW1-4)

| SW1-4 | BURNOUT |
|-------|-------------|
| OFF | Upscale (*) |
| ON | Downscale |

• Extension (SW1-1, 1-2)

| SW1-1 | SW1-2 | EXTENSION |
|-------|-------|---------------------------------|
| OFF | OFF | No extension (*) |
| ON | OFF | Discrete input, 8 or 16 points |
| OFF | ON | Discrete output, 8 or 16 points |

TERMINAL ASSIGNMENTS

| | | | | | | | | |
|------|------|------|------|----|------|------|------|------|
| 10 | 11 | 12 | 13 | 14 | 15 | 16 | 17 | 18 |
| +IN0 | -IN0 | +IN1 | -IN1 | NC | +IN2 | -IN2 | +IN3 | -IN3 |
| 1 | 2 | 3 | 4 | 5 | 6 | 7 | 8 | 9 |
| +CJ0 | -CJ0 | +CJ1 | -CJ1 | NC | +CJ2 | -CJ2 | +CJ3 | -CJ3 |

| NO. | ID | FUNCTION | NO. | ID | FUNCTION |
|-----|------|---------------|-----|------|---------------|
| 1 | +CJ0 | CJC + 0 | 10 | +IN0 | T/C + 0 |
| 2 | -CJ0 | CJC - 0 | 11 | -IN0 | T/C - 0 |
| 3 | +CJ1 | CJC + 1 | 12 | +IN1 | T/C + 1 |
| 4 | -CJ1 | CJC - 1 | 13 | -IN1 | T/C - 1 |
| 5 | NC | No connection | 14 | NC | No connection |
| 6 | +CJ2 | CJC + 2 | 15 | +IN2 | T/C + 2 |
| 7 | -CJ2 | CJC - 2 | 16 | -IN2 | T/C - 2 |
| 8 | +CJ3 | CJC + 3 | 17 | +IN3 | T/C + 3 |
| 9 | -CJ3 | CJC - 3 | 18 | -IN3 | T/C - 3 |

CIRCUIT DIAGRAM

Note: In order to improve EMC performance, bond the FG terminal to ground.

Caution: FG terminal is NOT a protective conductor terminal.



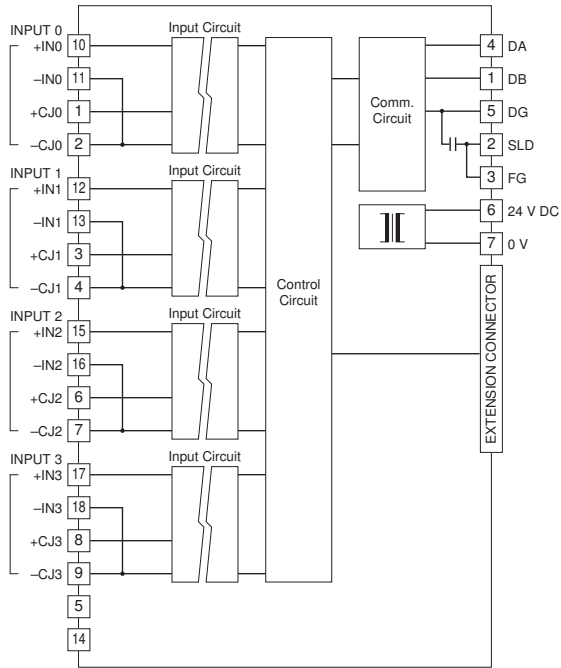

Input Connection Example

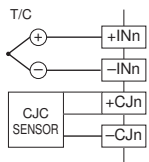

RTD INPUT MODULE, 4 points

MODEL: R7M-RS4

SPECIFICATIONS

Isolation: Input 0 to input 1 to input 2 to input 3 to Modbus or FG to power input

Converted data range: Engineering unit value (°C, K) × 10 (integer); No multiplication for °F

RTD: Pt 100 (JIS '97, IEC), Pt 100 (JIS '89), JPt 100 (JIS '89), Pt 50 Ω (JIS '81), Ni 100, Cu 10, Cu 50

Sensing current: ≤ 1 mA

Input resistance: ≥ 1 MΩ

Maximum leadwire resistance: 100 Ω per wire

Conversion accuracy: ±1°C (±1.8°F);

±3°C (±5.4°F) for Cu 10

Conversion rate: 250 msec. or 500 msec.

Response time: Conversion rate × 2 + 50 msec. (0 - 90 %)

Temperature coefficient: ±0.015 %/°C (±0.008 %/°F)

| RTD | BURNOUT INDICATION (°C) | | CONFORMANCE RANGE (°C) |
|-----------------------|-------------------------|---------|------------------------|
| | Downscale | Upscale | |
| Pt 100 (JIS '97, IEC) | -240 | +900 | -200 to +850 |
| Pt 100 (JIS '89) | -240 | +900 | -200 to +660 |
| JPt 100 (JIS '89) | -236 | +560 | -200 to +510 |
| Pt 50 Ω (JIS '81) | -236 | +700 | -200 to +649 |
| Ni 100 | -100 | +252 | -80 to +250 |
| Cu 10 (25°C) | -212 | +312 | -50 to +250 |
| Cu 50 | -100 | +200 | -50 to +150 |

| RTD | BURNOUT INDICATION (°F) | | CONFORMANCE RANGE (°F) |
|-----------------------|-------------------------|---------|------------------------|
| | Downscale | Upscale | |
| Pt 100 (JIS '97, IEC) | -400 | +1652 | -328 to +1562 |
| Pt 100 (JIS '89) | -400 | +1652 | -328 to +1220 |
| JPt 100 (JIS '89) | -393 | +1040 | -328 to +950 |
| Pt 50 Ω (JIS '81) | -393 | +1292 | -328 to +1200 |
| Ni 100 | -148 | +486 | -112 to +482 |
| Cu 10 (25°C) | -350 | +594 | -58 to +482 |
| Cu 50 | -148 | +392 | -58 to +302 |

OPERATING MODE SETTING

(*) Factory setting

• RTD type (SW1-5, 1-6, 1-7, 1-8)

| SW1-5 | SW1-6 | SW1-7 | SW1-8 | RTD TYPE |
|-------|-------|-------|-------|---------------------------|
| OFF | OFF | OFF | OFF | Pt 100 (JIS '97, IEC) (*) |
| ON | OFF | OFF | OFF | Pt 100 (JIS '89) |
| OFF | ON | OFF | OFF | JPt 100 (JIS '89) |
| ON | ON | OFF | OFF | Pt 50 Ω (JIS '81) |
| OFF | OFF | ON | OFF | Ni 100 |
| ON | OFF | ON | OFF | Cu 10 (25°C) |
| OFF | OFF | OFF | ON | Cu 50 |
| ON | ON | ON | ON | PC Configurator setting |

• Conversion rate (SW1-3)

| SW1-3 | CONVERSION RATE |
|-------|-----------------|
| OFF | 250 msec. (*) |
| ON | 500 msec. |

• Burnout (SW1-4)

| SW1-4 | BURNOUT |
|-------|-------------|
| OFF | Upscale (*) |
| ON | Downscale |

• Extension (SW1-1, 1-2)

| SW1-1 | SW1-2 | EXTENSION |
|-------|-------|---------------------------------|
| OFF | OFF | No extension (*) |
| ON | OFF | Discrete input, 8 or 16 points |
| OFF | ON | Discrete output, 8 or 16 points |

TERMINAL ASSIGNMENTS

| | | | | | | | | |
|------|------|------|------|----|------|------|------|------|
| 10 | 11 | 12 | 13 | 14 | 15 | 16 | 17 | 18 |
| INA0 | INb0 | INA1 | INb1 | NC | INA2 | INb2 | INA3 | INb3 |
| 1 | 2 | 3 | 4 | 5 | 6 | 7 | 8 | 9 |
| NC | INB0 | NC | INB1 | NC | NC | INB2 | NC | INB3 |

| NO. | ID | FUNCTION | NO. | ID | FUNCTION |
|-----|------|---------------|-----|------|---------------|
| 1 | NC | No connection | 10 | INA0 | RTD 0-A |
| 2 | INB0 | RTD 0-B | 11 | INb0 | RTD 0-b |
| 3 | NC | No connection | 12 | INA1 | RTD 1-A |
| 4 | INB1 | RTD 1-B | 13 | INb1 | RTD 1-b |
| 5 | NC | No connection | 14 | NC | No connection |
| 6 | NC | No connection | 15 | INA2 | RTD 2-A |
| 7 | INB2 | RTD 2-B | 16 | INb2 | RTD 2-b |
| 8 | NC | No connection | 17 | INA3 | RTD 3-A |
| 9 | INB3 | RTD 3-B | 18 | INb3 | RTD 3-b |

CIRCUIT DIAGRAM

Note: In order to improve EMC performance, bond the FG terminal to ground.

Caution: FG terminal is NOT a protective conductor terminal.



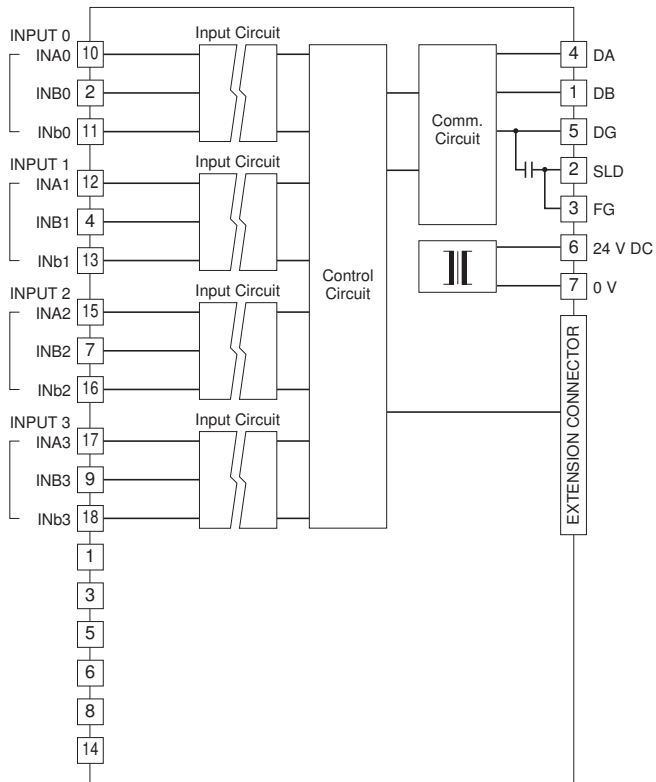

Input Connection Example

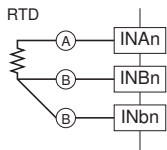

POTENTIOMETER INPUT MODULE, 4 points

MODEL: R7M-MS4

SPECIFICATIONS

Isolation: Input 0 to input 1 to input 2 to input 3 to Modbus or FG to power input

Converted data range: 0 - 10000 of the input range

Potentiometer: Total resistance 100 Ω - 20 kΩ

Minimum span: 50 % of total resistance

Excitation: Approx. 0.2 V DC

Conversion rate / conversion accuracy:

10 msec./±0.8 %, 20 msec./±0.4 %, 40 msec./±0.2 %, 80 msec./±0.1 %

Response time: Conversion rate × 2 + 50 msec. (0 - 90 %)

Temperature coefficient: ±0.015 %/°C (±0.008 %/°F)

OPERATING MODE SETTING

(*) Factory setting

Caution ! - SW1-5, 1-6, 1-7, 1-8 are unused. Be sure to turn off unused ones.

• Conversion rate / Accuracy (SW1-3, 1-4)

| SW1-3 | SW1-4 | CONVERSION RATE / ACCURACY |
|-------|-------|----------------------------|
| OFF | OFF | 80 msec. / ±0.1% (*) |
| ON | OFF | 40 msec. / ±0.2% |
| OFF | ON | 20 msec. / ±0.4% |
| ON | ON | 10 msec. / ±0.8% |

• Extension (SW1-1, 1-2)

| SW1-1 | SW1-2 | EXTENSION |
|-------|-------|---------------------------------|
| OFF | OFF | No extension (*) |
| ON | OFF | Discrete input, 8 or 16 points |
| OFF | ON | Discrete output, 8 or 16 points |

TERMINAL ASSIGNMENTS

| | | | | | | | | |
|----|----|----|----|----|----|----|----|----|
| 10 | 11 | 12 | 13 | 14 | 15 | 16 | 17 | 18 |
| H0 | S0 | H1 | S1 | NC | H2 | S2 | H3 | S3 |
| 1 | 2 | 3 | 4 | 5 | 6 | 7 | 8 | 9 |
| NC | L0 | NC | L1 | NC | NC | L2 | NC | L3 |

| NO. | ID | FUNCTION | NO. | ID | FUNCTION |
|-----|----|---------------|-----|----|---------------|
| 1 | NC | No connection | 10 | H0 | Pot H0 |
| 2 | L0 | Pot L0 | 11 | S0 | Pot S0 |
| 3 | NC | No connection | 12 | H1 | Pot H1 |
| 4 | L1 | Pot L1 | 13 | S1 | Pot S1 |
| 5 | NC | No connection | 14 | NC | No connection |
| 6 | NC | No connection | 15 | H2 | Pot H2 |
| 7 | L2 | Pot L2 | 16 | S2 | Pot S2 |
| 8 | NC | No connection | 17 | H3 | Pot H3 |
| 9 | L3 | Pot L3 | 18 | S3 | Pot S3 |

CIRCUIT DIAGRAM

Note: In order to improve EMC performance, bond the FG terminal to ground.

Caution: FG terminal is NOT a protective conductor terminal.

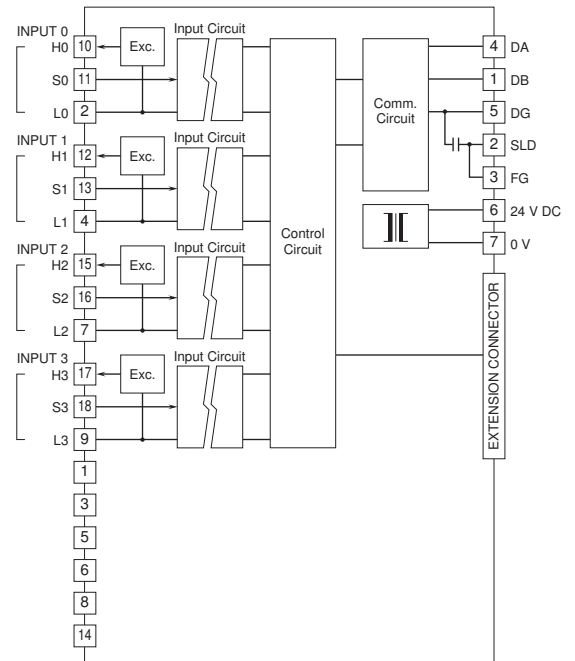

Input Connection Example

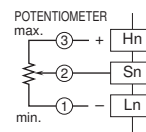

AC CURRENT INPUT MODULE, 4 points

(clamp-on current sensor CLSE use)

MODEL: R7M-CT4E

SPECIFICATIONS

Isolation: Input 0 to input 1 to input 2 to input 3 to Modbus or FG to power input

Converted data range:

Engineering unit value (A) × 100 (Integer)

(Engineering unit value (A) × 1000 (Integer) for CLSE-R5)

Input range (Optional)

CLSE-R5: 0 - 5 A AC

CLSE-05: 0 - 50 A AC

CLSE-10: 0 - 100 A AC

CLSE-20: 0 - 200 A AC

CLSE-40: 0 - 400 A AC

CLSE-60: 0 - 600 A AC

Frequency: 50/60 Hz

Overload capacity: 120 % continuous

Operational range: 5 - 115 % of rating

Conversion rate / conversion accuracy:

10 msec./±2.0 %, 20 msec./±1.0 %, 40 msec./±0.5 %, 80 msec./±0.5 %

(The conversion accuracy does not include the accuracy of the sensor.)

Response time: ≤ 1.0 sec. (0 - 90 %)

Temperature coefficient: ±0.015 %/°C (±0.008 %/°F)

OPERATING MODE SETTING

(*) Factory setting

• Input range (SW1-5, 1-6, 1-7, 1-8)

| SW1-5 | SW1-6 | SW1-7 | SW1-8 | INPUT RANGE |
|-------|-------|-------|-------|-------------------------|
| OFF | OFF | OFF | OFF | CLSE-60 (*) |
| ON | OFF | OFF | OFF | CLSE-40 |
| OFF | ON | OFF | OFF | CLSE-20 |
| ON | ON | OFF | OFF | CLSE-10 |
| OFF | OFF | ON | OFF | CLSE-05 |
| ON | OFF | ON | OFF | CLSE-R5 |
| ON | ON | ON | ON | PC Configurator setting |

• Conversion rate / Accuracy (SW1-3, 1-4)

| SW1-3 | SW1-4 | CONVERSION RATE / ACCURACY |
|-------|-------|----------------------------|
| OFF | OFF | 80 msec. / ±0.5% (*) |
| ON | OFF | 40 msec. / ±0.5% |
| OFF | ON | 20 msec. / ±1.0% |
| ON | ON | 10 msec. / ±2.0% |

• Extension (SW1-1, 1-2)

| SW1-1 | SW1-2 | EXTENSION |
|-------|-------|---------------------------------|
| OFF | OFF | No extension (*) |
| ON | OFF | Discrete input, 8 or 16 points |
| OFF | ON | Discrete output, 8 or 16 points |

TERMINAL ASSIGNMENTS

| 10 | 11 | 12 | 13 | 14 | 15 | 16 | 17 | 18 |
|----|----|----|----|----|----|----|----|----|
| K0 | L0 | K1 | L1 | NC | K2 | L2 | K3 | L3 |
| 1 | 2 | 3 | 4 | 5 | 6 | 7 | 8 | 9 |
| NC | NC | NC | NC | NC | NC | NC | NC | NC |

| NO. | ID | FUNCTION | NO. | ID | FUNCTION |
|-----|----|---------------|-----|----|---------------|
| 1 | NC | No connection | 10 | K0 | AC current K0 |
| 2 | NC | No connection | 11 | L0 | AC current L0 |
| 3 | NC | No connection | 12 | K1 | AC current K1 |
| 4 | NC | No connection | 13 | L1 | AC current L1 |
| 5 | NC | No connection | 14 | NC | No connection |
| 6 | NC | No connection | 15 | K2 | AC current K2 |
| 7 | NC | No connection | 16 | L2 | AC current L2 |
| 8 | NC | No connection | 17 | K3 | AC current K3 |
| 9 | NC | No connection | 18 | L3 | AC current L3 |

CIRCUIT DIAGRAM

Note: In order to improve EMC performance, bond the FG terminal to ground.

Caution: FG terminal is NOT a protective conductor terminal.

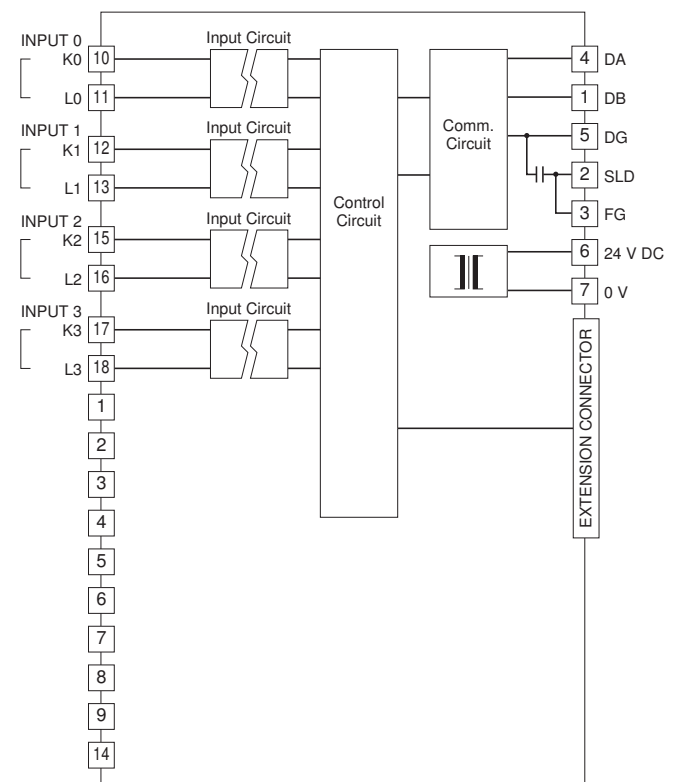

Input Connection Example

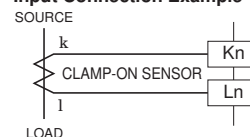

TOTALIZED PULSE INPUT MODULE, 8 points

MODEL: R7M-PA8

SPECIFICATIONS

Common: Positive or negative common (NPN/PNP) per 8 points

Number of I/O: Input, 8 points

Pulse Input status indicator: LED turns ON with contact ON

Isolation: Input to Modbus or FG to power input

■ **External excitation (PNP, NPN input)**

Sensing voltage: 24 V DC $\pm 10\%$; ripple 5 %p-p max

ON voltage / ON current: ≥ 16 V (input terminal - COM) / ≥ 3.7 mA

OFF voltage / OFF current: ≤ 5 V (input terminal - COM) / ≤ 1 mA

Voltage pulse input

ON voltage / ON current: ≥ 16 V DC (input terminal - COM) / ≤ 3.7 mA

OFF voltage / OFF current: ≤ 5 V DC (input terminal - COM) / ≤ 1 mA

Input current: ≤ 5.5 mA per point at 24 V DC

Input resistance: Approx. 4.4 k Ω

ON delay: ≤ 2.0 msec.

OFF delay: ≤ 2.0 msec.

Max. Frequency: 100 Hz

Minimum ON/OFF pulse requirements: 5 ms

Accumulated pulse count: 0 - 4 294 967 295

Max. accumulated pulse count: 1 000 - 4 294 967 295
(Factory default: 9 999 999)

Overflow: 0 or 1 (Factory default: 0)

OPERATING MODE SETTING

(*) Factory setting

Caution ! - SW1-3 through 1-8 are unused. Be sure to turn off unused ones.

• **Extension (SW1-1, 1-2)**

| SW1-1 | SW1-2 | EXTENSION |
|-------|-------|---------------------------------|
| OFF | OFF | No extension (*) |
| ON | OFF | Discrete input, 8 or 16 points |
| OFF | ON | Discrete output, 8 or 16 points |

TERMINAL ASSIGNMENTS

| | | | | | | | | |
|----|-----|-----|-----|-----|-----|-----|-----|-----|
| 10 | 11 | 12 | 13 | 14 | 15 | 16 | 17 | 18 |
| V+ | PI0 | PI1 | PI2 | PI3 | PI4 | PI5 | PI6 | PI7 |
| 1 | 2 | 3 | 4 | 5 | 6 | 7 | 8 | 9 |
| V- | C0 | C1 | C2 | C3 | C4 | C5 | C6 | C7 |

| NO. | ID | FUNCTION | NO. | ID | FUNCTION |
|-----|-----|-----------|-----|-----|-----------|
| 1 | V - | Power (-) | 10 | V + | Power (+) |
| 2 | C0 | Common | 11 | PI0 | Input 0 |
| 3 | C1 | Common | 12 | PI1 | Input 1 |
| 4 | C2 | Common | 13 | PI2 | Input 2 |
| 5 | C3 | Common | 14 | PI3 | Input 3 |
| 6 | C4 | Common | 15 | PI4 | Input 4 |
| 7 | C5 | Common | 16 | PI5 | Input 5 |
| 8 | C6 | Common | 17 | PI6 | Input 6 |
| 9 | C7 | Common | 18 | PI7 | Input 7 |

CIRCUIT DIAGRAM

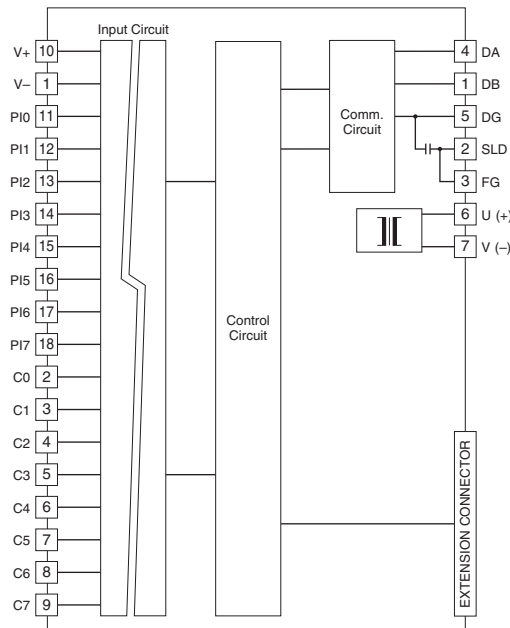

■ **Input Circuit**

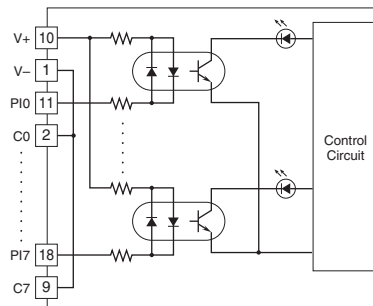

■ **Input Connection Examples**

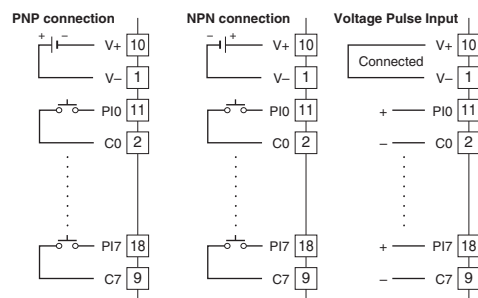

DC VOLTAGE OUTPUT MODULE, 2 points

MODEL: R7M-YV2

SPECIFICATIONS

Isolation: Output 0 to output 1 to Modbus or FG to power input

Converted data range: 0 - 10000 of the output range

Output range

Wide span voltage: -10 - +10 V DC, -5 - +5 V DC, 0 - 10 V DC, 0 - 5 V DC, 1 - 5 V DC

Narrow span voltage: -1 - +1 V DC, 0 - 1 V DC, -0.5 - +0.5 V DC

Operational range: -15 - +115 % of the output range (except -10 - +10 V DC);

approx. -11.5 - +11.5 V DC (-10 - +10 V DC)

Load resistance: $\geq 100 \text{ k}\Omega$

Conversion accuracy: $\pm 0.1 \%$

Response time: 250 msec. (0 - 90 %)

Temperature coefficient: $\pm 0.015 \%/^{\circ}\text{C}$ ($\pm 0.008 \%/^{\circ}\text{F}$)

OPERATING MODE SETTING

(*) Factory setting

Caution ! - SW1-3 is unused. Be sure to turn off unused ones.

• Output range (SW1-5, 1-6, 1-7, 1-8)

| SW1-5 | SW1-6 | SW1-7 | SW1-8 | OUTPUT RANGE |
|-------|-------|-------|-------|-------------------------|
| OFF | OFF | OFF | OFF | -10 - +10 V DC (*) |
| ON | OFF | OFF | OFF | -5 - +5 V DC |
| OFF | ON | OFF | OFF | -1 - +1 V DC |
| ON | ON | OFF | OFF | 0 - 10 V DC |
| OFF | OFF | ON | OFF | 0 - 5 V DC |
| ON | OFF | ON | OFF | 1 - 5 V DC |
| OFF | ON | ON | OFF | 0 - 1 V DC |
| ON | ON | ON | OFF | -0.5 - +0.5 V DC |
| ON | ON | ON | ON | PC Configurator setting |

• Output at the loss of communication (SW1-4)

| SW1-4 | OUTPUT AT THE LOSS OF COMMUNICATION |
|-------|--|
| OFF | Reset the output (to -15% or approx. -11.5V DC) |
| ON | Hold the output (*) (maintains the last data received normally) |

• Extension (SW1-1, 1-2)

| SW1-1 | SW1-2 | EXTENSION |
|-------|-------|---------------------------------|
| OFF | OFF | No extension (*) |
| ON | OFF | Discrete input, 8 or 16 points |
| OFF | ON | Discrete output, 8 or 16 points |

TERMINAL ASSIGNMENTS

| | | | | |
|----|------|------|------|------|
| 6 | 7 | 8 | 9 | 10 |
| NC | VH0 | VL0 | VH1 | VL1 |
| 1 | 2 | 3 | 4 | 5 |
| NC | COM0 | COM0 | COM1 | COM1 |

| NO. | ID | FUNCTION | NO. | ID | FUNCTION |
|-----|------|---------------|-----|-----|---------------------|
| 1 | NC | No connection | 6 | NC | No connection |
| 2 | COM0 | Common 0 | 7 | VH0 | Wide span volt. 0 |
| 3 | COM0 | Common 0 | 8 | VL0 | Narrow span volt. 0 |
| 4 | COM1 | Common 1 | 9 | VH1 | Wide span volt. 1 |
| 5 | COM1 | Common 1 | 10 | VL1 | Narrow span volt. 1 |

CIRCUIT DIAGRAM

Note: In order to improve EMC performance, bond the FG terminal to ground.

Caution: FG terminal is NOT a protective conductor terminal.

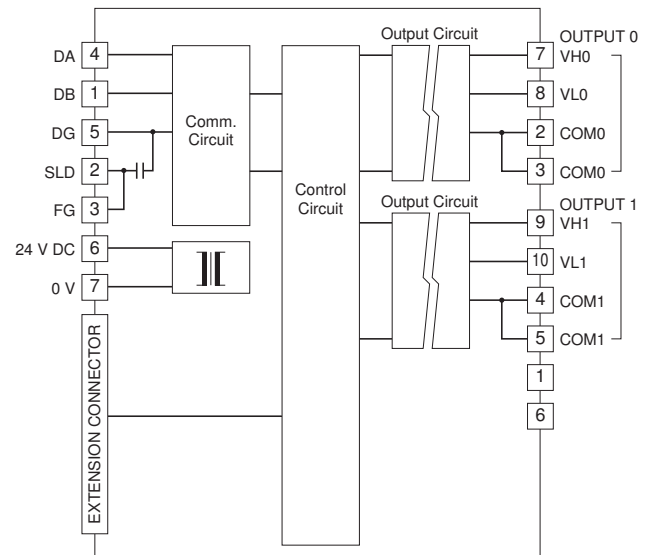

Output Connection Examples

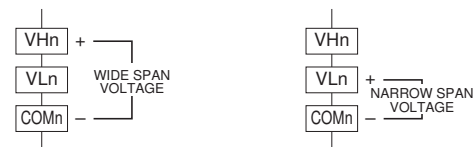

DC CURRENT OUTPUT MODULE, 2 points

MODEL: R7M-YS2

SPECIFICATIONS

Isolation: Output 0 to output 1 to Modbus or FG to power input

Converted data range: 0 - 10000 of the output range

Output range: 4 - 20 mA DC

Load resistance: ≤ 600Ω

Conversion accuracy: ±0.1 %

Response time: 250 msec. (0 - 90 %)

Temperature coefficient: ±0.015 %/°C (±0.008 %/°F)

OPERATING MODE SETTING

(*) Factory setting

Caution ! - SW1-3, 1-5 through 1-8 are unused. Be sure to turn off unused ones.

• **Output at the loss of communication (SW1-4)**

| SW1-4 | OUTPUT AT THE LOSS OF COMMUNICATION |
|-------|--|
| OFF | Reset the output (to -15%) |
| ON | Hold the output (*) (maintains the last data received normally) |

• **Extension (SW1-1, 1-2)**

| SW1-1 | SW1-2 | EXTENSION |
|-------|-------|---------------------------------|
| OFF | OFF | No extension (*) |
| ON | OFF | Discrete input, 8 or 16 points |
| OFF | ON | Discrete output, 8 or 16 points |

TERMINAL ASSIGNMENTS

| | | | | |
|----|------|----|------|----|
| 6 | 7 | 8 | 9 | 10 |
| NC | I0 | NC | I1 | NC |
| 1 | 2 | 3 | 4 | 5 |
| NC | COM0 | NC | COM1 | NC |

| NO. | ID | FUNCTION | NO. | ID | FUNCTION |
|-----|------|---------------|-----|----|---------------|
| 1 | NC | No connection | 6 | NC | No connection |
| 2 | COM0 | Common 0 | 7 | I0 | Current 0 |
| 3 | NC | No connection | 8 | NC | No connection |
| 4 | COM1 | Common 1 | 9 | I1 | Current 1 |
| 5 | NC | No connection | 10 | NC | No connection |

CIRCUIT DIAGRAM

Note: In order to improve EMC performance, bond the FG terminal to ground.

Caution: FG terminal is NOT a protective conductor terminal.

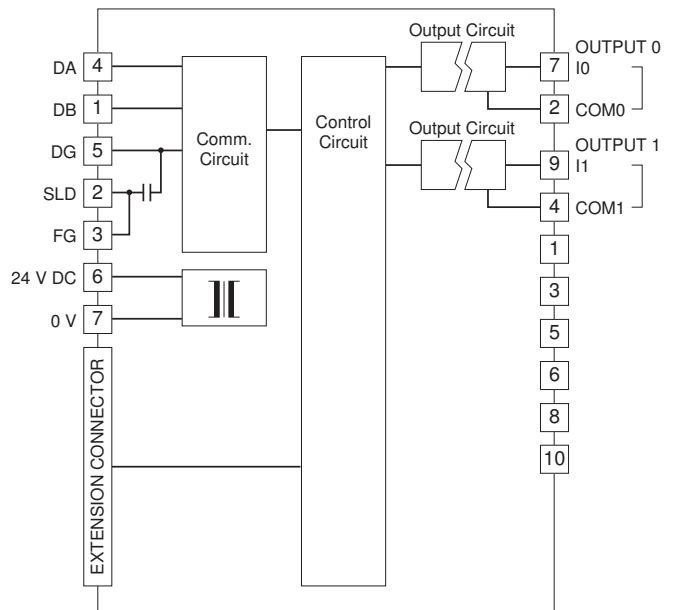

DISCRETE INPUT EXTENSION MODULE, 8 points

CIRCUIT DIAGRAM

MODEL: R7M-EA8

SPECIFICATIONS

Common: Positive or negative common (NPN/PNP) per 8 points

Number of I/O: Input, 8 points

Maximum inputs applicable at once: No limit (at 24 V DC)

Input status indicator LED: Turns ON with contact ON

Isolation: Input to internal circuits

Rated input voltage: 24 V DC $\pm 10\%$; ripple 5 %p-p max.

ON voltage / current: ≥ 15 V DC (input - COM) / ≥ 3.5 mA

OFF voltage / current: ≤ 5 V DC (input - COM) / ≤ 1 mA

Input current: ≤ 5.5 mA per point at 24 V DC

Input resistance: Approx. 4.4 k Ω

ON delay: ≤ 2.0 msec.

OFF delay: ≤ 2.0 msec.

TERMINAL ASSIGNMENTS

| | | | | |
|-----|----|----|----|----|
| 6 | 7 | 8 | 9 | 10 |
| NC | X1 | X3 | X5 | X7 |
| 1 | 2 | 3 | 4 | 5 |
| COM | X0 | X2 | X4 | X6 |

| NO. | ID | FUNCTION | NO. | ID | FUNCTION |
|-----|-----|----------|-----|----|---------------|
| 1 | COM | Common | 6 | NC | No Connection |
| 2 | X0 | Input 0 | 7 | X1 | Input 1 |
| 3 | X2 | Input 2 | 8 | X3 | Input 3 |
| 4 | X4 | Input 4 | 9 | X5 | Input 5 |
| 5 | X6 | Input 6 | 10 | X7 | Input 7 |

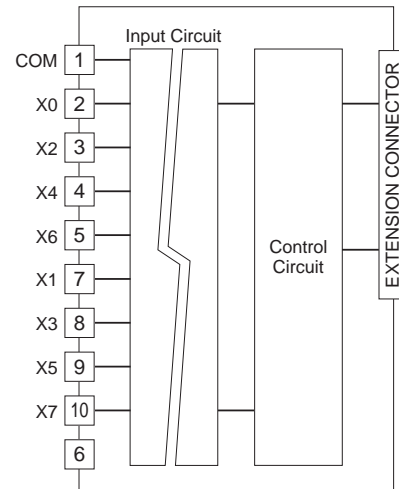

Input Circuit

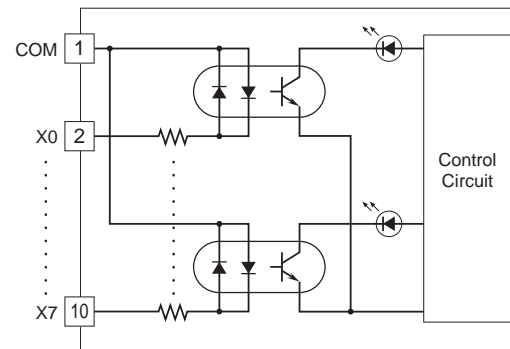

Input Connection Examples

PNP Connection

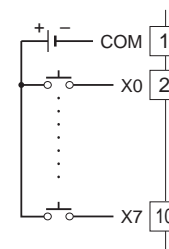

NPN Connection

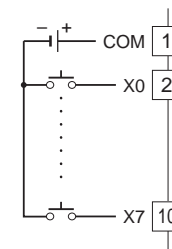

DISCRETE INPUT EXTENSION MODULE, 16 points

CIRCUIT DIAGRAM

MODEL: R7M-EA16

SPECIFICATIONS

- Common:** Positive or negative common (PNP/NPN) per 16 points
- Number of I/O:** Input, 16 points
- Maximum inputs applicable at once:** No limit (at 24 V DC)
- Input status indicator LED:** Turns ON with contact ON
- Isolation:** Input to internal circuits
- Rated input voltage:** 24 V DC $\pm 10\%$; ripple 5 %p-p max.
- ON voltage / current:** ≥ 15 V DC (input - COM) / ≥ 3.5 mA
- OFF voltage / current:** ≤ 5 V DC (input - COM) / ≤ 1 mA
- Input current:** ≤ 5.5 mA per point at 24 V DC
- Input resistance:** Approx. 4.4 k Ω
- ON delay:** ≤ 2.0 msec.
- OFF delay:** ≤ 2.0 msec.

TERMINAL ASSIGNMENTS

| | | | | | | | | |
|-----|----|----|----|----|----|----|----|----|
| 10 | 11 | 12 | 13 | 14 | 15 | 16 | 17 | 18 |
| NC | X1 | X3 | X5 | X7 | X9 | XB | XD | XF |
| 1 | 2 | 3 | 4 | 5 | 6 | 7 | 8 | 9 |
| COM | X0 | X2 | X4 | X6 | X8 | XA | XC | XE |

| NO. | ID | FUNCTION | NO. | ID | FUNCTION |
|-----|-----|----------|-----|----|---------------|
| 1 | COM | Common | 10 | NC | No Connection |
| 2 | X0 | Input 0 | 11 | X1 | Input 1 |
| 3 | X2 | Input 2 | 12 | X3 | Input 3 |
| 4 | X4 | Input 4 | 13 | X5 | Input 5 |
| 5 | X6 | Input 6 | 14 | X7 | Input 7 |
| 6 | X8 | Input 8 | 15 | X9 | Input 9 |
| 7 | XA | Input 10 | 16 | XB | Input 11 |
| 8 | XC | Input 12 | 17 | XD | Input 13 |
| 9 | XE | Input 14 | 18 | XF | Input 15 |

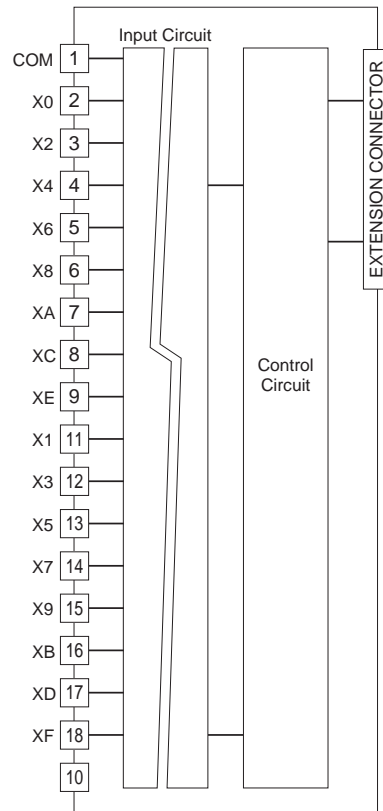

Input Circuit

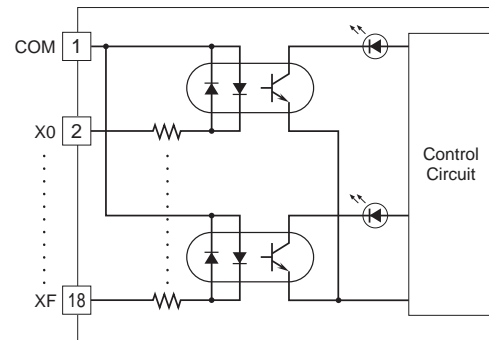

Input Connection Examples

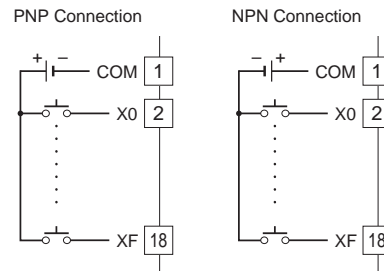

NPN TRANSISTOR OUTPUT EXTENSION MODULE, 8 points

CIRCUIT DIAGRAM

MODEL: R7M-EC8A

SPECIFICATIONS

- Common:** Negative common (NPN) per 8 points
- Number of I/O:** Output, 8 points
- Maximum outputs applicable at once:** No limit (at 24 V DC)
- Output status indicator:** LED turns ON with contact ON
- Isolation:** Output to internal circuits
- Rated load voltage:** 24 V DC $\pm 10\%$
- Rated output current:** 0.25 A per point, 2.0 A per common
- Residual voltage:** ≤ 1.2 V
- Leakage current:** ≤ 0.1 mA
- ON delay:** ≤ 0.5 msec.
- OFF delay:** ≤ 1.5 msec.

TERMINAL ASSIGNMENTS

| | | | | |
|-------|----|----|----|----|
| 6 | 7 | 8 | 9 | 10 |
| +24 V | Y1 | Y3 | Y5 | Y7 |
| 1 | 2 | 3 | 4 | 5 |
| 0 V | Y0 | Y2 | Y4 | Y6 |

| NO. | ID | FUNCTION | NO. | ID | FUNCTION |
|-----|-----|--------------|-----|-------|----------|
| 1 | 0 V | 0 V (common) | 6 | +24 V | 24 V DC |
| 2 | Y0 | Output 0 | 7 | Y1 | Output 1 |
| 3 | Y2 | Output 2 | 8 | Y3 | Output 3 |
| 4 | Y4 | Output 4 | 9 | Y5 | Output 5 |
| 5 | Y6 | Output 6 | 10 | Y7 | Output 7 |

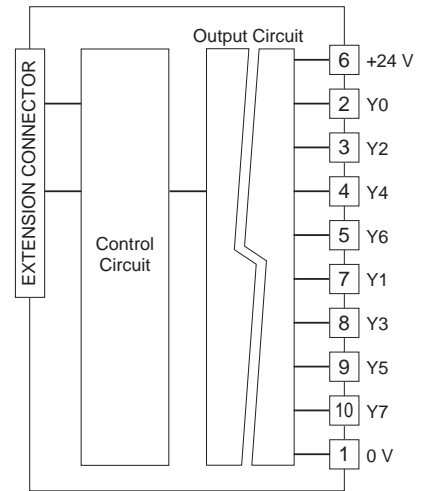

Output Circuit

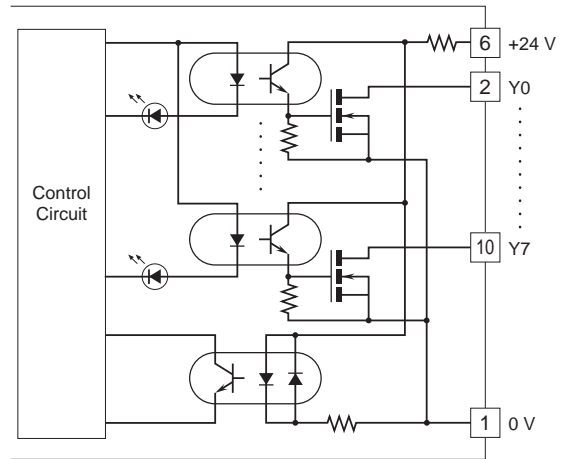

Output Connection Example

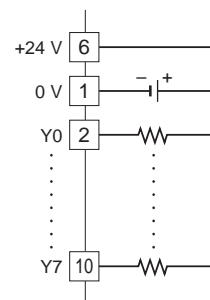

NPN TRANSISTOR OUTPUT EXTENSION MODULE, 16 points

CIRCUIT DIAGRAM

MODEL: R7M-EC16A

SPECIFICATIONS

- Common:** Negative common (NPN) per 16 points
- Number of I/O:** Output, 16 points
- Maximum outputs applicable at once:** No limit (at 24 V DC)
- Output status indicator:** LED turns ON with contact ON
- Isolation:** Output to internal circuits
- Rated load voltage:** 24 V DC $\pm 10\%$
- Rated output current:** 0.25 A per point, 2.0 A per common
- Residual voltage:** ≤ 1.2 V
- Leakage current:** ≤ 0.1 mA
- ON delay:** ≤ 0.5 msec.
- OFF delay:** ≤ 1.5 msec.

TERMINAL ASSIGNMENTS

| | | | | | | | | |
|-------|----|----|----|----|----|----|----|----|
| 10 | 11 | 12 | 13 | 14 | 15 | 16 | 17 | 18 |
| +24 V | Y1 | Y3 | Y5 | Y7 | Y9 | YB | YD | YF |
| 1 | 2 | 3 | 4 | 5 | 6 | 7 | 8 | 9 |
| 0 V | Y0 | Y2 | Y4 | Y6 | Y8 | YA | YC | YE |

| NO. | ID | FUNCTION | NO. | ID | FUNCTION |
|-----|-----|--------------|-----|-------|-----------|
| 1 | 0 V | 0 V (common) | 10 | +24 V | 24 V DC |
| 2 | Y0 | Output 0 | 11 | Y1 | Output 1 |
| 3 | Y2 | Output 2 | 12 | Y3 | Output 3 |
| 4 | Y4 | Output 4 | 13 | Y5 | Output 5 |
| 5 | Y6 | Output 6 | 14 | Y7 | Output 7 |
| 6 | Y8 | Output 8 | 15 | Y9 | Output 9 |
| 7 | YA | Output 10 | 16 | YB | Output 11 |
| 8 | YC | Output 12 | 17 | YD | Output 13 |
| 9 | YE | Output 14 | 18 | YF | Output 15 |

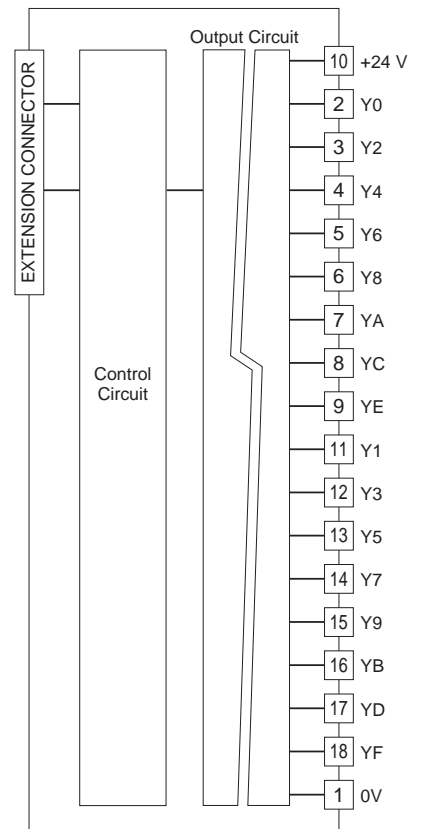

Output Circuit

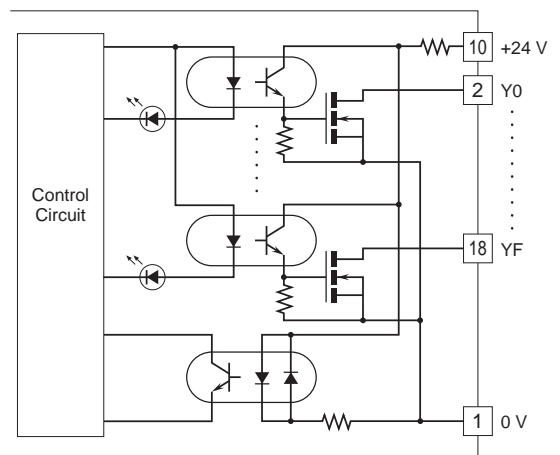

Output Connection Example

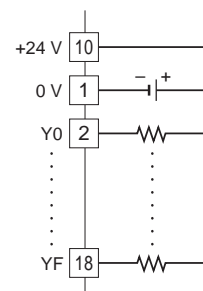

PNP TRANSISTOR OUTPUT EXTENSION MODULE, 8 points

CIRCUIT DIAGRAM

MODEL: R7M-EC8B

SPECIFICATIONS

- Common:** Positive common (PNP) per 8 points
- Number of I/O:** Output, 8 points
- Maximum outputs applicable at once:** No limit (at 24 V DC)
- Output status indicator:** LED turns ON with contact ON
- Isolation:** Output to internal circuits
- Rated load voltage:** 24 V DC $\pm 10\%$
- Rated output current:** 0.25 A per point, 2.0 A per common
- Residual voltage:** ≤ 1.2 V
- Leakage current:** ≤ 0.1 mA
- ON delay:** ≤ 0.5 msec.
- OFF delay:** ≤ 1.5 msec.

TERMINAL ASSIGNMENTS

| | | | | |
|-------|----|----|----|----|
| 6 | 7 | 8 | 9 | 10 |
| +24 V | Y1 | Y3 | Y5 | Y7 |
| 1 | 2 | 3 | 4 | 5 |
| 0 V | Y0 | Y2 | Y4 | Y6 |

| NO. | ID | FUNCTION | NO. | ID | FUNCTION |
|-----|-----|----------|-----|-------|------------------|
| 1 | 0 V | 0 V | 6 | +24 V | 24 V DC (common) |
| 2 | Y0 | Output 0 | 7 | Y1 | Output 1 |
| 3 | Y2 | Output 2 | 8 | Y3 | Output 3 |
| 4 | Y4 | Output 4 | 9 | Y5 | Output 5 |
| 5 | Y6 | Output 6 | 10 | Y7 | Output 7 |

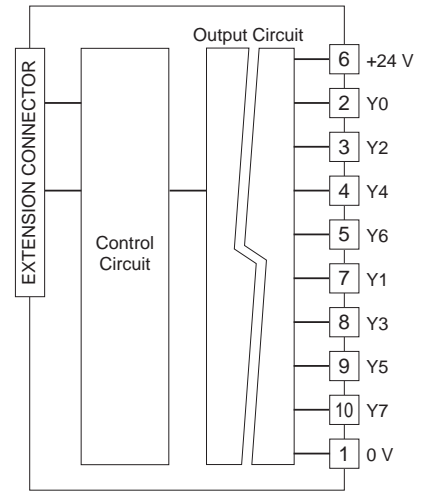

Output Circuit

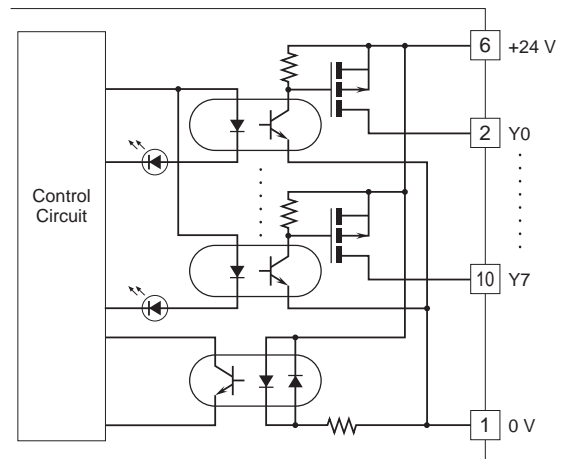

Output Connection Example

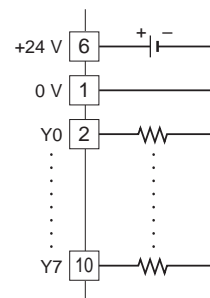

PNP TRANSISTOR OUTPUT EXTENSION MODULE, 16 points

CIRCUIT DIAGRAM

MODEL: R7M-EC16B

SPECIFICATIONS

- Common:** Positive common (PNP) per 16 points
- Number of I/O:** Output, 16 points
- Maximum outputs applicable at once:** No limit (at 24 V DC)
- Output status indicator:** LED turns ON with contact ON
- Isolation:** Output to internal circuits
- Rated load voltage:** 24 V DC $\pm 10\%$
- Rated output current:** 0.25 A per point, 2.0 A per common
- Residual voltage:** ≤ 1.2 V
- Leakage current:** ≤ 0.1 mA
- ON delay:** ≤ 0.5 msec.
- OFF delay:** ≤ 1.5 msec.

TERMINAL ASSIGNMENTS

| | | | | | | | | |
|-------|----|----|----|----|----|----|----|----|
| 10 | 11 | 12 | 13 | 14 | 15 | 16 | 17 | 18 |
| +24 V | Y1 | Y3 | Y5 | Y7 | Y9 | YB | YD | YF |
| 1 | 2 | 3 | 4 | 5 | 6 | 7 | 8 | 9 |
| 0 V | Y0 | Y2 | Y4 | Y6 | Y8 | YA | YC | YE |

| NO. | ID | FUNCTION | NO. | ID | FUNCTION |
|-----|-----|-----------|-----|-------|------------------|
| 1 | 0 V | 0 V | 10 | +24 V | 24 V DC (common) |
| 2 | Y0 | Output 0 | 11 | Y1 | Output 1 |
| 3 | Y2 | Output 2 | 12 | Y3 | Output 3 |
| 4 | Y4 | Output 4 | 13 | Y5 | Output 5 |
| 5 | Y6 | Output 6 | 14 | Y7 | Output 7 |
| 6 | Y8 | Output 8 | 15 | Y9 | Output 9 |
| 7 | YA | Output 10 | 16 | YB | Output 11 |
| 8 | YC | Output 12 | 17 | YD | Output 13 |
| 9 | YE | Output 14 | 18 | YF | Output 15 |

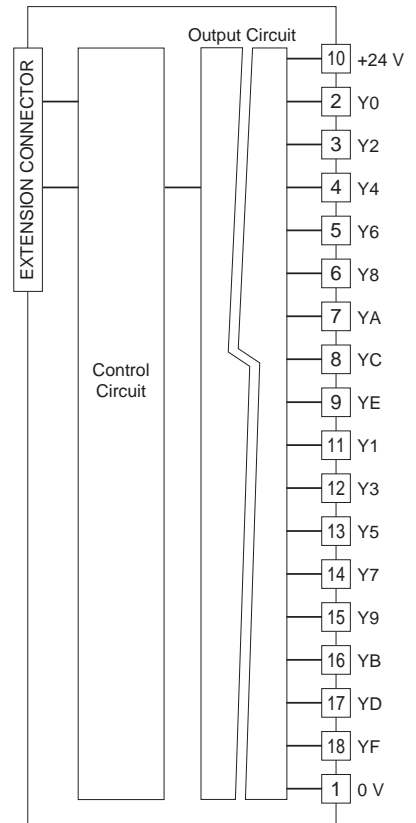

Output Circuit

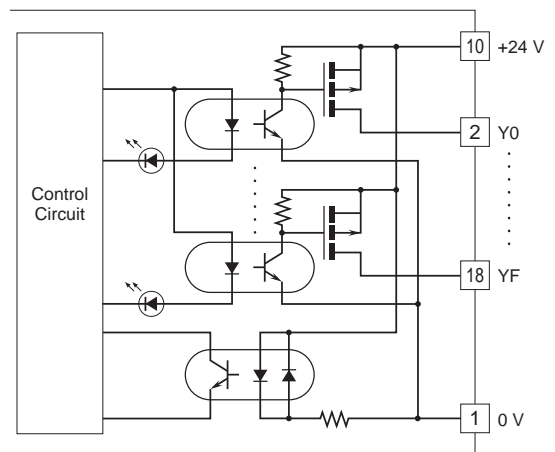

Output Connection Example

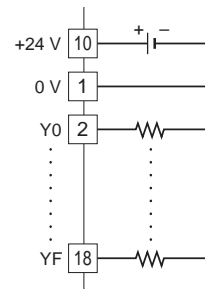

RELAY CONTACT OUTPUT EXTENSION MODULE

CIRCUIT DIAGRAM

MODEL: R7M-EC8C

SPECIFICATIONS

- Common:** 1 common per 4 points (4 terminals)
 - Common current:** Max. 8 A (4 terminals)
 - Number of I/O:** Relay contact output, 8 points
 - Maximum outputs applicable at once:** No limit (at 24 V DC)
 - Output status indicator:** LED turns ON with contact ON
 - Isolation:** Output to internal circuits
 - Relay driving power:** 24 V DC $\pm 10\%$, ≥ 60 mA
 - Rated load:** 250 V AC @ 2 A ($\cos \phi = 1$)
30 V DC @ 2 A (resistive load)
 - Maximum switching voltage:** 250 V AC or 30 V DC
 - Maximum switching power:** 500 VA or 60 W
 - Minimum load:** 24 V DC @ 5 mA
 - Mechanical life:** 2×10^7 cycles (rate 300/min.)
- When driving an inductive load, external contact protection and noise quenching are recommended.
- ON delay:** ≤ 10 msec.
 - OFF delay:** ≤ 10 msec.

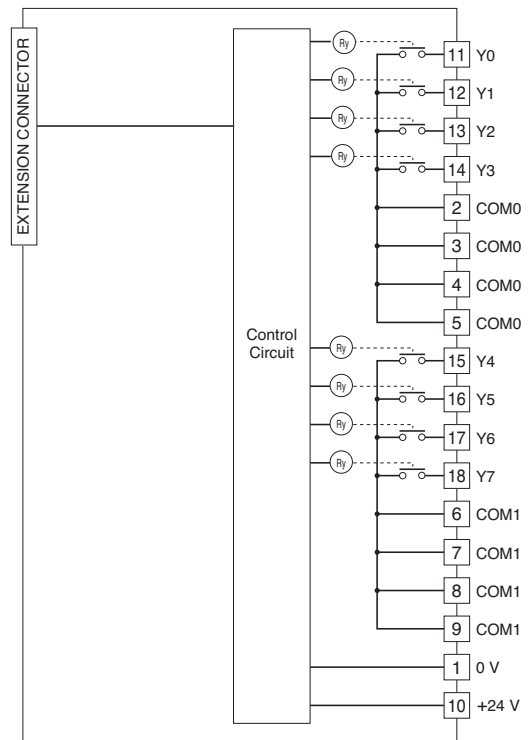

TERMINAL ASSIGNMENTS

| | | | | | | | | |
|-------|------|------|------|------|------|------|------|------|
| 10 | 11 | 12 | 13 | 14 | 15 | 16 | 17 | 18 |
| +24 V | Y0 | Y1 | Y2 | Y3 | Y4 | Y5 | Y6 | Y7 |
| 1 | 2 | 3 | 4 | 5 | 6 | 7 | 8 | 9 |
| 0 V | COM0 | COM0 | COM0 | COM0 | COM1 | COM1 | COM1 | COM1 |

| NO. | ID | FUNCTION | NO. | ID | FUNCTION |
|-----|------|----------|-----|-------|----------|
| 1 | 0 V | 0 V | 10 | +24 V | 24 V DC |
| 2 | COM0 | Common 0 | 11 | Y0 | Output 0 |
| 3 | COM0 | Common 0 | 12 | Y1 | Output 1 |
| 4 | COM0 | Common 0 | 13 | Y2 | Output 2 |
| 5 | COM0 | Common 0 | 14 | Y3 | Output 3 |
| 6 | COM1 | Common 1 | 15 | Y4 | Output 4 |
| 7 | COM1 | Common 1 | 16 | Y5 | Output 5 |
| 8 | COM1 | Common 1 | 17 | Y6 | Output 6 |
| 9 | COM1 | Common 1 | 18 | Y7 | Output 7 |

Output Connection Example

4 points / common

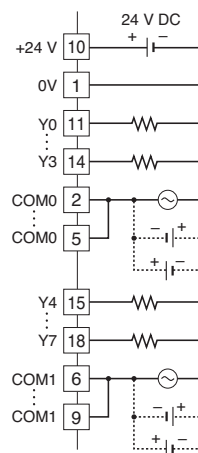

8 points / common

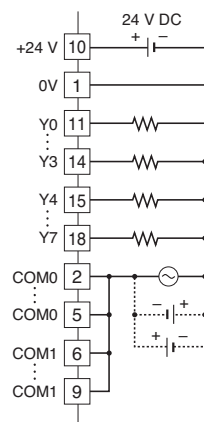



Specifications are subject to change without notice.

