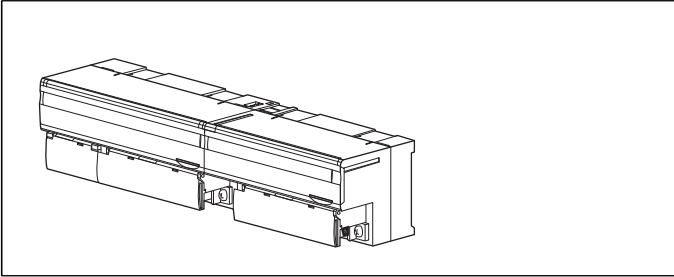

Remote I/O R7 Series**LonWorks I/O MODULE****ORDERING INFORMATION**

- Basic module: R7L-[1]-AR

Specify a code from below for [1].

(e.g. R7L-DC16A-AR)

- Extension module: R7L-[1]

Specify a code from below for each [1].

(e.g. R7L-EC16A)

MODEL: R7L-[1]-AR**[1] I/O TYPE**

DA16: Discrete input, 16 points

DC16A: NPN transistor output, 16 points
(One-shot pulse output is available.)

DC16B: PNP transistor output, 16 points
(One-shot pulse output is available.)

DAC16: Discrete input, 8 points
NPN transistor output, 8 points

(One-shot pulse output is available.)

SV4: DC voltage/current input (10 V/20 mA), 4 points

TS4: Thermocouple input, 4 points

RS4: RTD input, 4 points

YV2: DC voltage output, 2 points

YS2: DC current output, 2 points

RR8: Remote control relay control output, 8 points

R7L-DA16 and -DAC16 can accept totalized pulse input with no need of input extension module. Other modules need extension module.

POWER INPUT

AR: 24 V AC/DC

EXTENSION MODULE: R7L-[1]**[1] I/O TYPE**

EA8: Discrete input, 8 points

EA16: Discrete input, 16 points

EC8A: NPN transistor output, 8 points

EC16A: NPN transistor output, 16 points

EC8B: PNP transistor output, 8 points

EC16B: PNP transistor output, 16 points

FUNCTIONS & FEATURES

The R7L interfaces analog and discrete I/O signals with a PC via LonWorks.

A 'basic' module can be attached with an 'extension' module. By combining two modules, single station can handle mixed analog and discrete signals, 32-point discrete inputs, 32-point discrete outputs, 16-point discrete I/Os and other combinations of signals.

Single module can handle multiple Functional Blocks, not only the discrete I/O, but also the pulse count input, one-shot output, scaling, alarm output, and so forth.

Input sensor type (thermocouple, RTD) and range can be selected using the LNS Plug-in Software (model: R7LPLG).

RELATED PRODUCTS

- XIF File (Device Interface File)

XIF file is used to define a LonWorks device when programmed on LonMaker.

- LNS Plug-in Software (model: R7LPLG)

XIF files and LNS Plug-in Software are downloadable at M-System's web site.

LonWorks SYSTEM REQUIREMENTS

- LonMaker Turbo Edition Ver.3.2 or higher + LonMaker Turbo Service Pack 4.0 or higher
- LonMark Resource File Ver.13 or higher

GENERAL SPECIFICATIONS**■ Common Specifications**

Power input: 24 V AC $\pm 10\%$ (50 / 60 Hz) / 24 V DC $\pm 10\%$

Insulation resistance: $\geq 100\text{ M}\Omega$ with 500 V DC

Dielectric strength: 1500 V AC @1 minute
(between isolated circuits)

Operating temperature: -10 to +55°C (14 to 131°F)

Operating humidity: 30 to 90 %RH (non-condensing)

Atmosphere: No corrosive gas or heavy dust

Storage temperature: -20 to +65°C (-4 to +149°F)

Mounting: DIN rail (35 mm wide)

Connection: M3 screw terminals (torque 0.5 N·m)

Screw terminal material: Nickel-plated steel



Recommended solderless terminal: Refer to the drawing at the end of the section.

Applicable wire size 0.3 to 0.75 mm²

Status indicator LEDs: PWR, ONLINE, ERR, TX/RX, SVCE
(Refer to the instruction manual for details)

Neuron Chip: FT3120 (NeuronID printed in numeric and bar code [peel-off code 39 format] under the specification marking on the product; two sticker labels attached)

Transceiver: FT-X1 (equivalent to FTT10A)

Transmission speed: 78 kbps

Twisted-pair cable

Distance, free topology: 500 meters

Max. 64 nodes/channel

■ Current Consumption & Weight

Current consumption at 24 V AC / 24 V DC

R7L-DA16: 70 mA / 40 mA; 200 g (7.1 oz)

R7L-DC16A: 80 mA / 50 mA; 200 g (7.1 oz)

R7L-DC16B: 80 mA / 50 mA; 200 g (7.1 oz)

R7L-DAC16: 75 mA / 45 mA; 200 g (7.1 oz)

R7L-SV4: 80 mA / 50 mA; 200 g (7.1 oz)

R7L-TS4: 85 mA / 50 mA; 200 g (7.1 oz)

R7L-RS4: 85 mA / 50 mA; 200 g (7.1 oz)

R7L-YV2: 110 mA / 70 mA; 200 g (7.1 oz)

R7L-YS2: 180 mA / 110 mA; 200 g (7.1 oz)

R7L-RR8: 75 mA / 50 mA; 200 g (7.1 oz)

R7L-EA8: 15 mA / 10 mA; 90 g (3.2 oz)

R7L-EA16: 30 mA / 20 mA; 150 g (5.3 oz)

R7L-EC8A: 15 mA / 10 mA; 90 g (3.2 oz)

R7L-EC16A: 30 mA / 20 mA; 150 g (5.3 oz)

R7L-EC8B: 15 mA / 10 mA; 90 g (3.2 oz)

R7L-EC16B: 30 mA / 20 mA; 150 g (5.3 oz)

■ Recommended solderless terminal (unit: mm(inch))

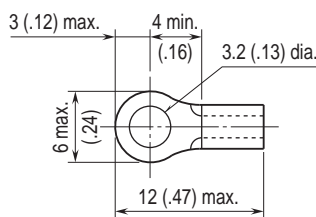

■ I/O Status Indicator LED

• Discrete I/O

Discrete I/O modules have LED indicators showing I/O signal status.

• Analog I/O

Analog I/O modules have LED indicators showing network variable status assigned to fbLED.

(Refer to the instruction manual for details)

■ Service Switch

Used to identify the node in LonWorks network configuration.

■ Reset Switch

Used to reset the Neuron Chip. Press the switch behind the

front cover to reset.

Control functions are halted while completing resetting and restarting. Confirm no danger before conducting resetting.



EXTERNAL VIEW

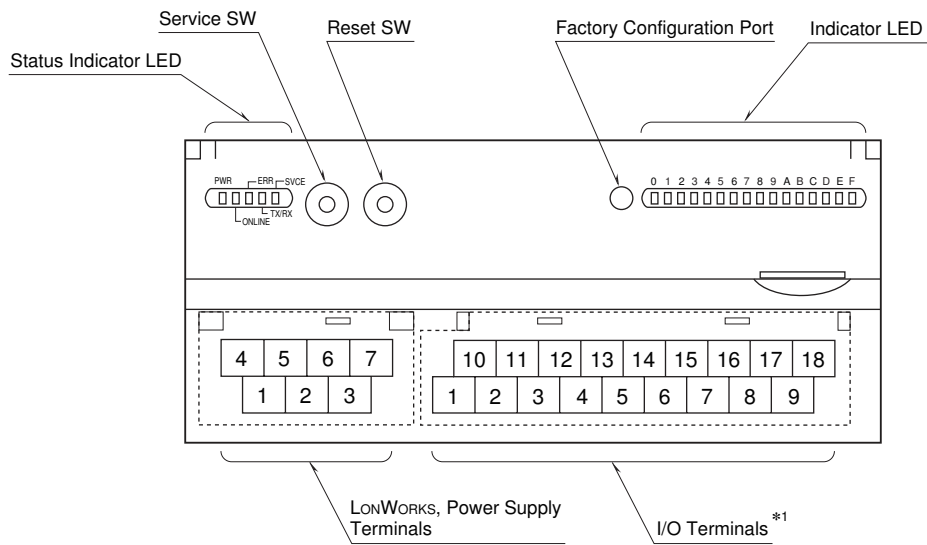

*1. 10 screw terminals for analog output modules.

CONNECTION DIAGRAMS

■ POWER SUPPLY, LonWorks TERMINAL ASSIGNMENT

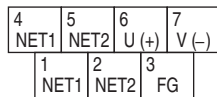

NO.	ID	FUNCTION, NOTES
1	NET1	LonWorks communication 1
2	NET2	LonWorks communication 2
3	FG	FG
4	NET1	LonWorks communication 1
5	NET2	LonWorks communication 2
6	U (+)	Power input
7	V (-)	Power input

Note: LONWORKS wiring must be paired between Net1 terminals and/or Net2 terminals.

■ HOST PC CONNECTION

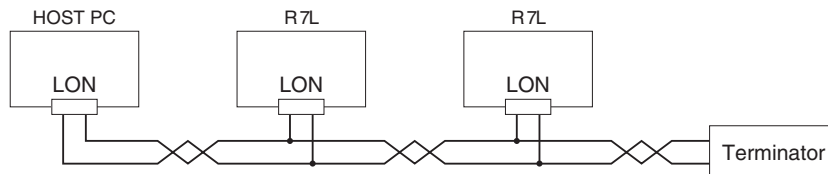

DATA CONVERSION

■ 0 – 100% DATA CONVERSION

Analog input data is converted into digital representations of 0 – 100% proportional to each scaled range. The converted % values are expressed in signed 16 bits.

Overrange input is possible from -15 to +115% of the nominal range. When the signal exceeds the limit, the data is fixed at -15% or +115% respectively.

- Input Range 0 – 5V DC

Input Value	Input %	Converted Data, Decimal
$\leq -0.75V$	-15%	-15.00
0V	0%	0.00
5V	100%	100.00
$\geq 5.75V$	115%	115.00

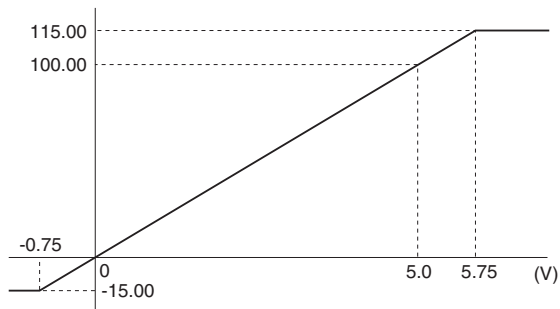

Analog output is converted in the reverse order of the input data. The output range 0 – 5V DC is expressed as 100.00 at 5.0V (100%) and 0.00 at 0V (0%).

■ TEMPERATURE DATA CONVERSION

Temperature data (thermocouple and RTD) are represented in engineering unit value, °C, expressed in signed 16 bits.

- Input Type K Thermocouple

Input Value	Converted Data, Decimal
$\leq -272^{\circ}C$	-272.0
$-150^{\circ}C$	-150.0
$1370^{\circ}C$	1370.0
$\geq 1472^{\circ}C$	1472.0

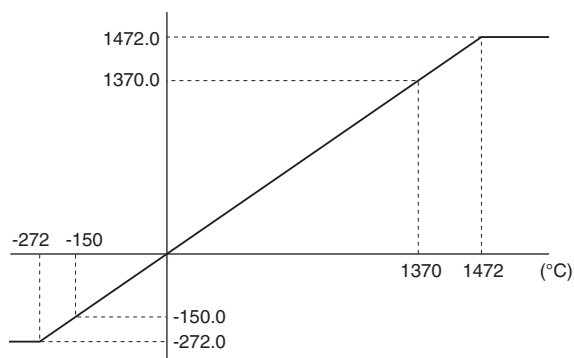

EXTENSION MODULE

A 'basic' module can be attached with one 'extension' module. The extension module is powered from the basic module. By combining two modules, single station can handle mixed analog and discrete signals.

Settings of the extension module are handled by Functional Blocks of the basic module. Refer to the instruction manual of the basic module for more information.

■ OUTPUT AT THE LOSS OF COMMUNICATION

The extension module is set to 'Hold Output' by factory default setting. The LNS Plug-in Software (model: R7LPLG) is used to change the setting to 'Reset Output.'

■ CONNECTING THE EXTENSION MODULE

- 1) Remove the extension connector cover located at the side of the basic module.
- 2) Connect the extension module.

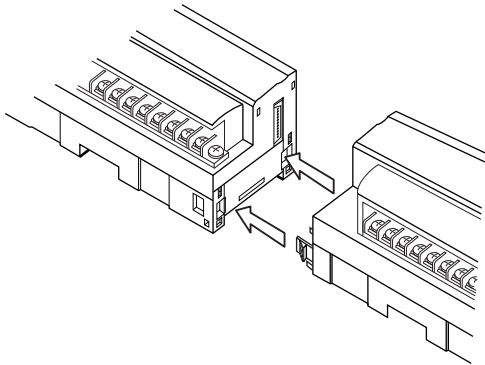

- 3) Mount the combined module on a DIN rail.

DIMENSIONS unit: mm (inch)

■ BASIC MODULE

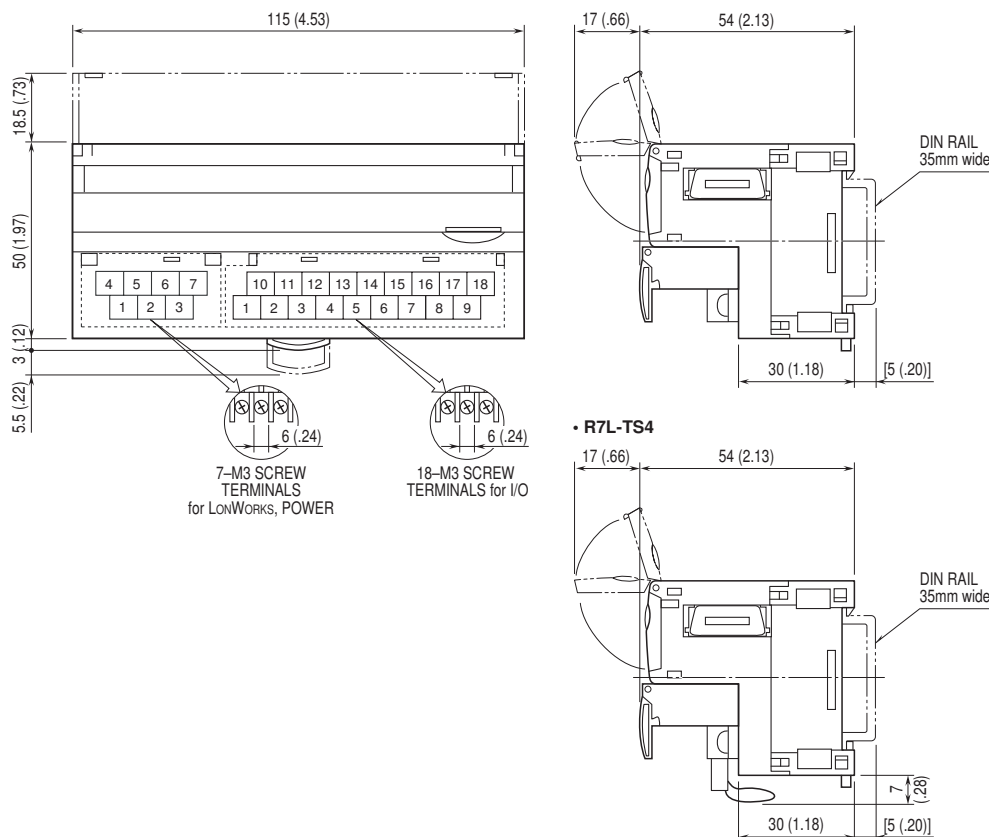

■ ANALOG OUTPUT

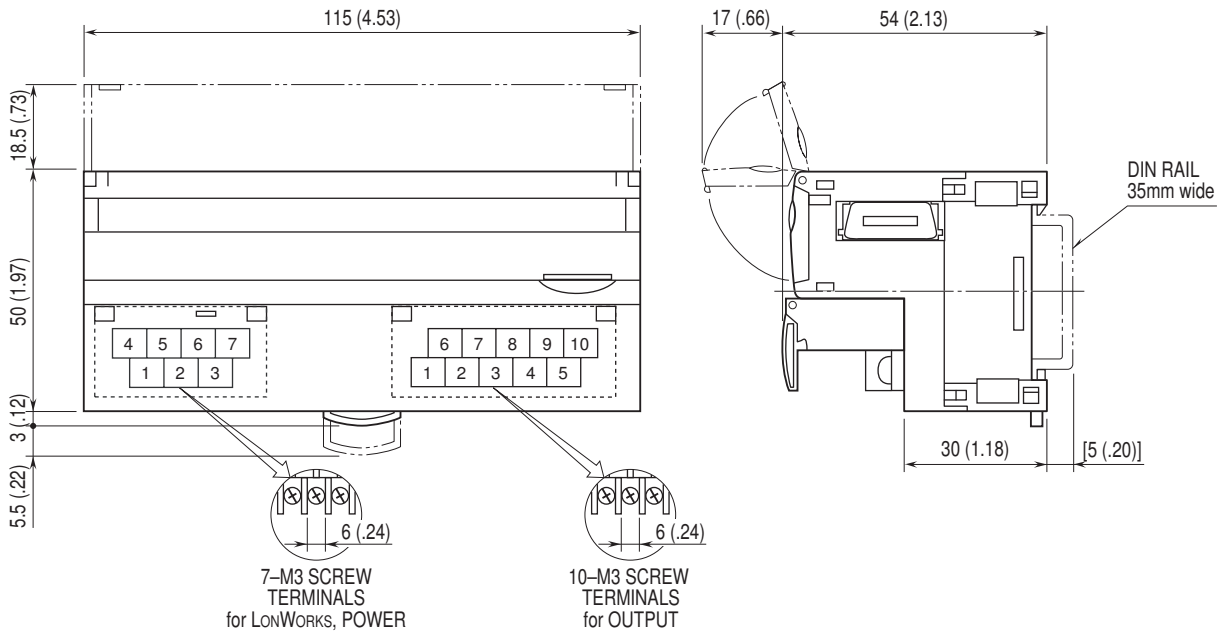

■ EXTENSION MODULE, 8 POINTS

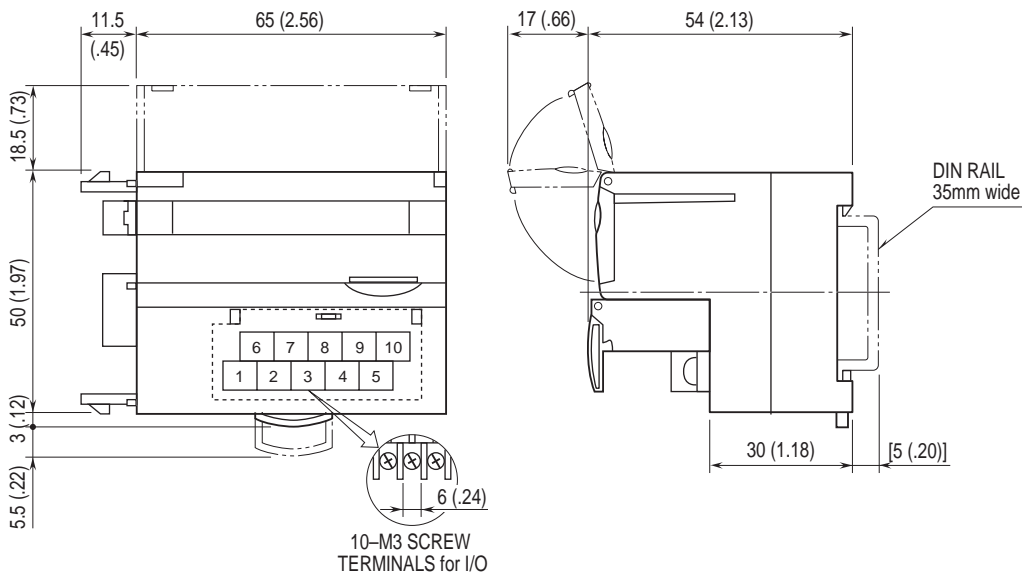

■ EXTENSION MODULE, 16 POINTS

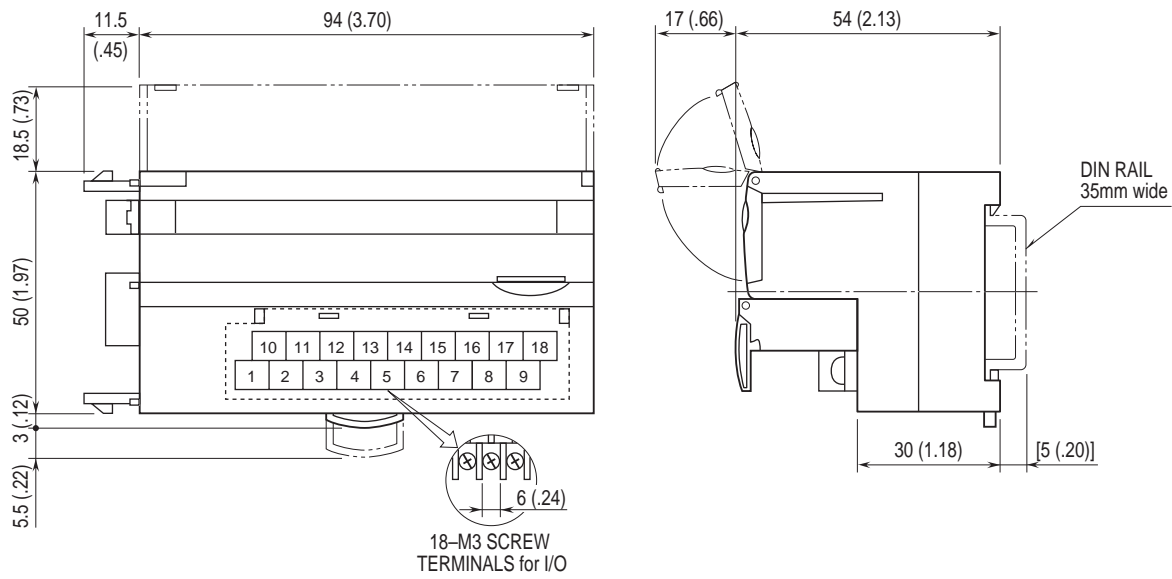

DISCRETE INPUT MODULE, 16 points

MODEL: R7L-DA16

SPECIFICATIONS

- Common:** Positive or negative common (NPN/PNP) per 16 points
- Number of I/O:** Input, 16 points
- Maximum inputs applicable at once:** No limit (at 24 V DC)
- I/O status indicator:** LED turns on with closed contact.
- Isolation:** Input to LonWorks or FG or power
- Rated input voltage:** 24 V DC $\pm 10\%$; ripple 5 %p-p max.
- ON voltage / current:** ≥ 15 V DC (input - COM) / ≥ 3.5 mA
- OFF voltage / current:** ≤ 5 V DC (input - COM) / ≤ 1 mA
- Input current:** ≤ 5.5 mA per point at 24 V DC
- Input resistance:** Approx. 4.4 k Ω
- Maximum input frequency:** 10 Hz (input terminal)
1 Hz (Network Variable)
- Minimum input pulse requirements:** 50 ms (input terminal)
500 ms (Network Variable)
- Accumulated pulse count:** 0 - 999 999 999
(Maximum count depends upon Network Variable types)
- Overflow:** Reset to 0 and restart counting

FUNCTIONAL BLOCKS

The following Functional Blocks are usable. Refer to the instruction manual for detailed information.

- NodeObject (extension module setting)
- fbCNT (totalize pulse count on 8 channels)
- fbDI (discrete input, RS-flip flop)
- fbCMP (compare)
- fbEN (encoder)
- fbTMR (timer)
- fbDOEX (discrete output, extension module)
- fbDIEX (discrete input, extension module)

TERMINAL ASSIGNMENTS

10	11	12	13	14	15	16	17	18
NC	X1	X3	X5	X7	X9	XB	XD	XF
1	2	3	4	5	6	7	8	9
COM	X0	X2	X4	X6	X8	XA	XC	XE

NO.	ID	FUNCTION	NO.	ID	FUNCTION
1	COM	Common	10	NC	No Connection
2	X0	Input 0	11	X1	Input 1
3	X2	Input 2	12	X3	Input 3
4	X4	Input 4	13	X5	Input 5
5	X6	Input 6	14	X7	Input 7
6	X8	Input 8	15	X9	Input 9
7	XA	Input 10	16	XB	Input 11
8	XC	Input 12	17	XD	Input 13
9	XE	Input 14	18	XF	Input 15

CIRCUIT DIAGRAM

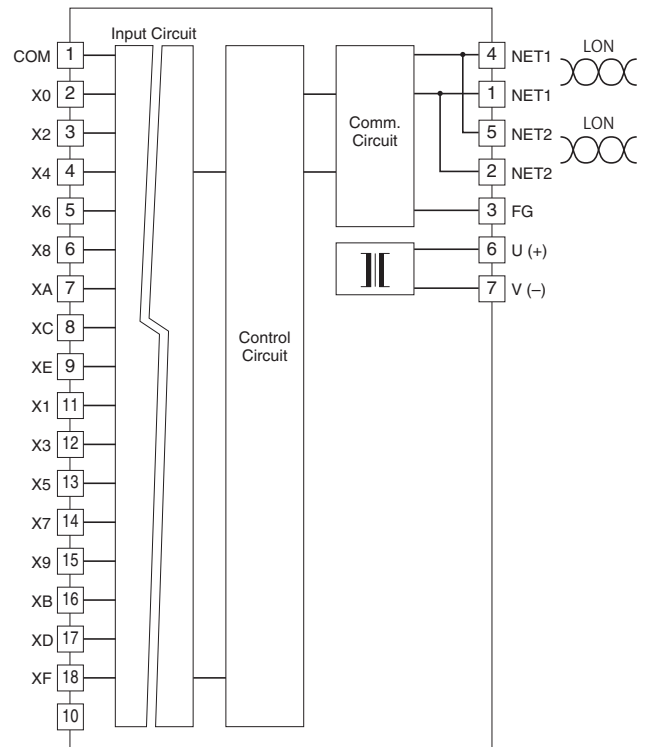

Input Circuit

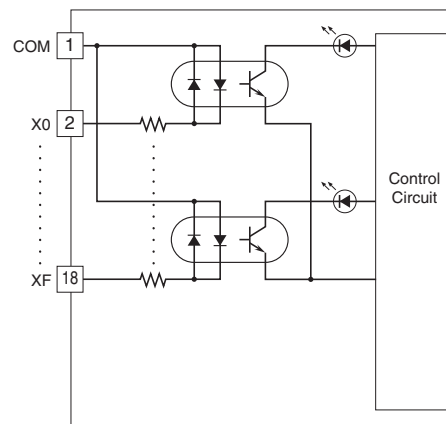

Input Connection Examples

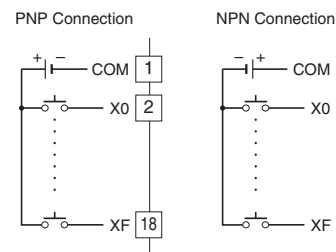

NPN TRANSISTOR OUTPUT MODULE, 16 points

MODEL: R7L-DC16A

SPECIFICATIONS

- Common:** Negative common (NPN) per 16 points
- Number of I/O:** Output, 16 points
- Maximum outputs applicable at once:** No limit (at 24 V DC)
- I/O status indicator:** LED turns on with closed contact.
- Isolation:** Output to LonWorks or FG or power
- Rated load voltage:** 24 V DC $\pm 10\%$
- Rated output current:** 0.25 A per point, 2.0 A per common
- Residual voltage:** ≤ 1.2 V
- Leakage current:** ≤ 0.1 mA

FUNCTIONAL BLOCKS

The following Functional Blocks are usable. Refer to the instruction manual for detailed information.

- NodeObject (extension module setting)
- fbCNT (count)
- fbDO (discrete output, one-shot output)
- fbCMP (compare)
- fbEN (encoder)
- fbTMR (timer)
- fbDOEX (discrete output, extension module)
- fbDIEX (discrete input, extension module)

TERMINAL ASSIGNMENTS

10	11	12	13	14	15	16	17	18
+24 V	Y1	Y3	Y5	Y7	Y9	YB	YD	YF
1	2	3	4	5	6	7	8	9
0 V	Y0	Y2	Y4	Y6	Y8	YA	YC	YE

NO.	ID	FUNCTION	NO.	ID	FUNCTION
1	0 V	0 V (common)	10	+24 V	24 V DC
2	Y0	Output 0	11	Y1	Output 1
3	Y2	Output 2	12	Y3	Output 3
4	Y4	Output 4	13	Y5	Output 5
5	Y6	Output 6	14	Y7	Output 7
6	Y8	Output 8	15	Y9	Output 9
7	YA	Output 10	16	YB	Output 11
8	YC	Output 12	17	YD	Output 13
9	YE	Output 14	18	YF	Output 15

CIRCUIT DIAGRAM

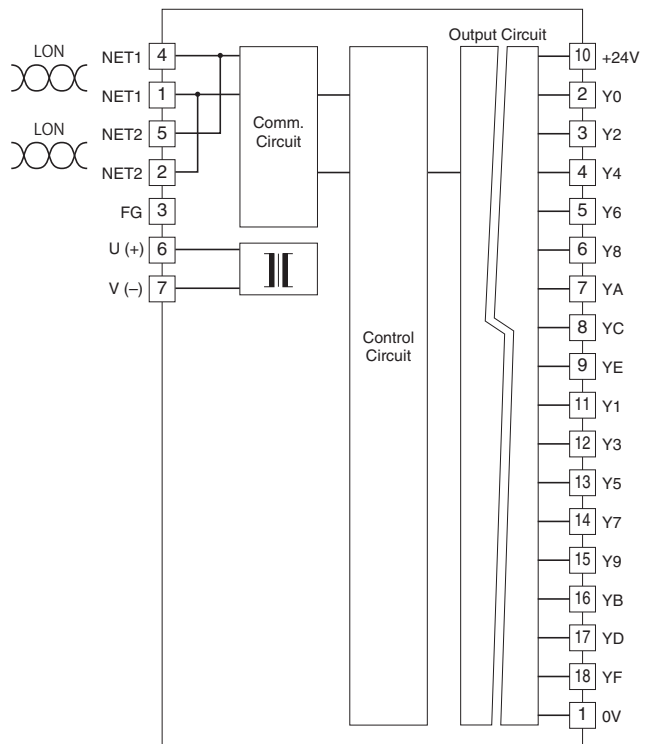

Output Circuit

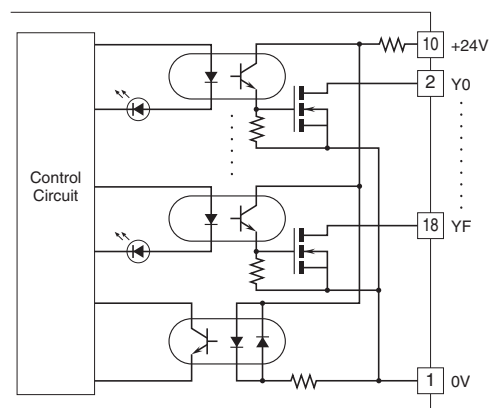

Output Connection Example

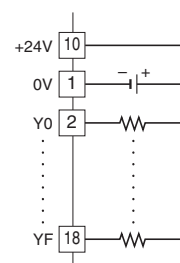

PNP TRANSISTOR OUTPUT MODULE, 16 points

MODEL: R7L-DC16B

SPECIFICATIONS

- Common:** Positive common (PNP) per 16 points
- Number of I/O:** Output, 16 points
- Maximum outputs applicable at once:** No limit (at 24 V DC)
- I/O status indicator:** LED turns on with closed contact.
- Isolation:** Output to LonWorks or FG or power
- Rated load voltage:** 24 V DC $\pm 10\%$
- Rated output current:** 0.25 A per point, 2.0 A per common
- Residual voltage:** ≤ 1.2 V
- Leakage current:** ≤ 0.1 mA

FUNCTIONAL BLOCKS

The following Functional Blocks are usable. Refer to the instruction manual for detailed information.

- NodeObject (extension module setting)
- fbCNT (count)
- fbDO (discrete output, one-shot output)
- fbCMP (compare)
- fbEN (encoder)
- fbTMR (timer)
- fbDOEX (discrete output, extension module)
- fbDIEX (discrete input, extension module)

TERMINAL ASSIGNMENTS

10	11	12	13	14	15	16	17	18
+24 V	Y1	Y3	Y5	Y7	Y9	YB	YD	YF
1	2	3	4	5	6	7	8	9
0 V	Y0	Y2	Y4	Y6	Y8	YA	YC	YE

NO.	ID	FUNCTION	NO.	ID	FUNCTION
1	0 V	0 V	10	+24 V	24 V DC (common)
2	Y0	Output 0	11	Y1	Output 1
3	Y2	Output 2	12	Y3	Output 3
4	Y4	Output 4	13	Y5	Output 5
5	Y6	Output 6	14	Y7	Output 7
6	Y8	Output 8	15	Y9	Output 9
7	YA	Output 10	16	YB	Output 11
8	YC	Output 12	17	YD	Output 13
9	YE	Output 14	18	YF	Output 15

CIRCUIT DIAGRAM

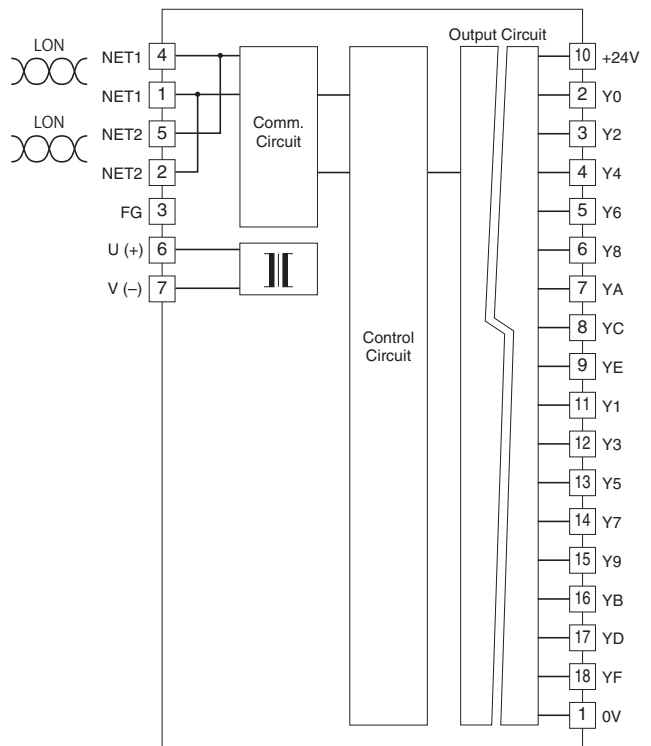

Output Circuit

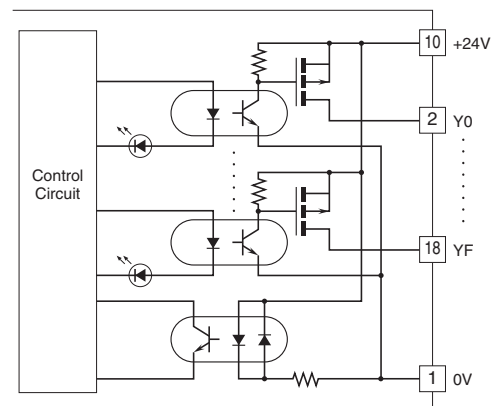

Output Connection Example

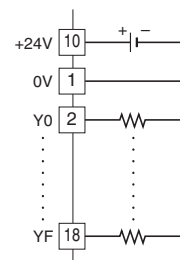

DISCRETE INPUT & NPN TRANSISTOR OUTPUT MODULE, 8 points each

MODEL: R7L-DAC16

SPECIFICATIONS

COMMON SPECIFICATIONS

Common: Negative common (NPN) per 16 points
Number of I/O: Input, 8 points; Output, 8 points
Maximum I/O applicable at once: No limit (at 24 V DC)
I/O status indicator: LED turns on with closed contact.
Isolation: Input or output to LonWorks or FG or power

INPUT

Rated input voltage: 24 V DC $\pm 10\%$; ripple 5 %p-p max.
ON voltage / current: ≥ 15 V DC (input - COM) / ≥ 3.5 mA
OFF voltage / current: ≤ 5 V DC (input - COM) / ≤ 1 mA
Input current: ≤ 5.5 mA per point at 24 V DC
Input resistance: Approx. 4.4 k Ω
Maximum input frequency: 10 Hz (input terminal)
 1 Hz (Network Variable)

Minimum input pulse requirements: 50 ms (input terminal)
 500 ms (Network Variable)

Accumulated pulse count: 0 - 999 999 999
 (Maximum count depends upon Network Variable types)

Overflow: Reset to 0 and restart counting

OUTPUT

Rated load voltage: 24 V DC $\pm 10\%$
Rated output current: 0.25 A per point, 2.0 A per common
Residual voltage: ≤ 1.2 V
Leakage current: ≤ 0.1 mA

FUNCTIONAL BLOCKS

The following Functional Blocks are usable. Refer to the instruction manual for detailed information.

- NodeObject (extension module setting)
- fbCNT (totalize pulse count on 8 channels)
- fbDO (discrete output, one-shot output)
- fbDI (discrete input, RS-flip flop)
- fbCMP (compare)
- fbEN (encoder)
- fbTMR (timer)
- fbDOEX (discrete output, extension module)
- fbDIEX (discrete input, extension module)

TERMINAL ASSIGNMENTS

10	11	12	13	14	15	16	17	18
+24V	X1	X3	X5	X7	Y1	Y3	Y5	Y7
1	2	3	4	5	6	7	8	9
COM	X0	X2	X4	X6	Y0	Y2	Y4	Y6

NO.	ID	FUNCTION	NO.	ID	FUNCTION
1	COM	Common	10	+24V	24V DC
2	X0	Input 0	11	X1	Input 1
3	X2	Input 2	12	X3	Input 3
4	X4	Input 4	13	X5	Input 5
5	X6	Input 6	14	X7	Input 7
6	Y0	Output 0	15	Y1	Output 1
7	Y2	Output 2	16	Y3	Output 3
8	Y4	Output 4	17	Y5	Output 5
9	Y6	Output 6	18	Y7	Output 7

CIRCUIT DIAGRAM

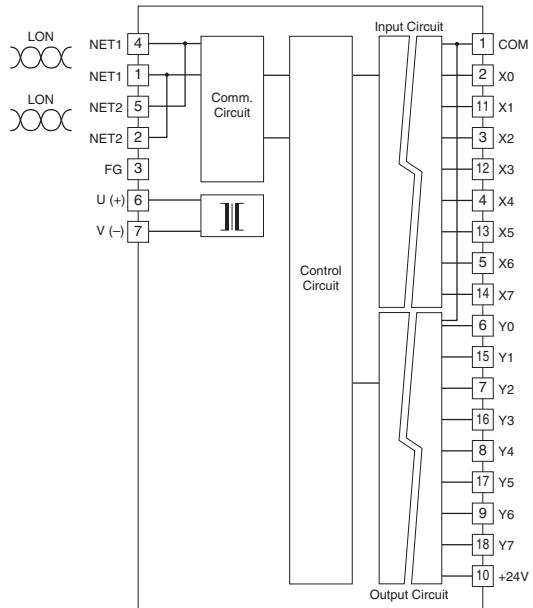

Input Circuit

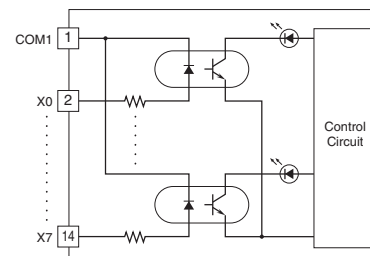

Output Circuit

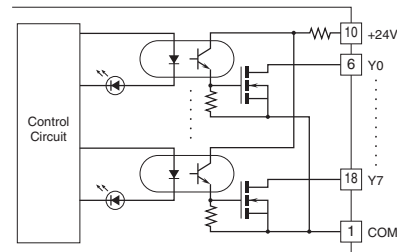

I/O Connection Example

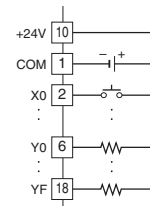

DC VOLTAGE/CURRENT INPUT MODULE, 4 points

CIRCUIT DIAGRAM

MODEL: R7L-SV4

SPECIFICATIONS

Isolation: Input 0 to input 1 to input 2 to input 3 to power input or LonWorks or FG

Converted data range: 0 - 100.00 of the input range

Input range

Wide span voltage: -10 - +10 V DC(*), -5 - +5 V DC, 0 - 10 V DC, 0 - 5 V DC, 1 - 5 V DC;

(*) Factory setting

Narrow span voltage: -1 - +1 V DC, 0 - 1 V DC, -0.5 - +0.5 V DC, 0 - 0.5 V DC;

Current range: -20 - +20 mA DC, 0 - 20 mA DC, 4 - 20 mA DC

(Input range is selectable using the LNS Plug-in Software (model: R7LPLG))

• **Input resistance**

Wide span voltage: $\geq 1 \text{ M}\Omega$

Narrow span voltage: $\geq 100 \text{ k}\Omega$

Current range: 70 Ω

Conversion rate / conversion accuracy: 80 msec. / $\pm 0.1 \%$

Temperature coefficient: $\pm 0.015 \%/^{\circ}\text{C}$ ($\pm 0.008 \%/^{\circ}\text{F}$)

FUNCTIONAL BLOCKS

The following Functional Blocks are usable. Refer to the instruction manual for detailed information.

- NodeObject (extension module setting)
- fbCNT (count)
- fbSV (DC voltage/current input, input range)
- fbARM (alarm output)
- fbCV (scaling)
- fbLED (LED function)
- fbDOEX (discrete output, extension module)
- fbDIEX (discrete input, extension module)

TERMINAL ASSIGNMENTS

10	11	12	13	14	15	16	17	18
VL0	IO	VL1	I1	NC	VL2	I2	VL3	I3
1	2	3	4	5	6	7	8	9
VH0	COM0	VH1	COM1	NC	VH2	COM2	VH3	COM3

NO.	ID	FUNCTION	NO.	ID	FUNCTION
1	VH0	Wide span volt. 0	10	VL0	Narrow span volt. 0
2	COM0	Common 0	11	IO	Current range 0
3	VH1	Wide span volt. 1	12	VL1	Narrow span volt. 1
4	COM1	Common 1	13	I1	Current range 1
5	NC	No connection	14	NC	No connection
6	VH2	Wide span volt. 2	15	VL2	Narrow span volt. 2
7	COM2	Common 2	16	I2	Current range 2
8	VH3	Wide span volt. 3	17	VL3	Narrow span volt. 3
9	COM3	Common 3	18	I3	Current range 3

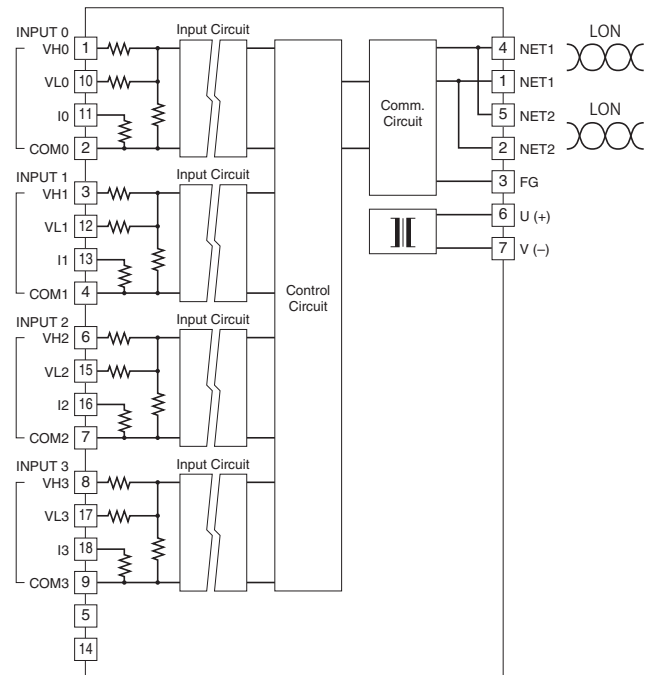

Input Connection Examples

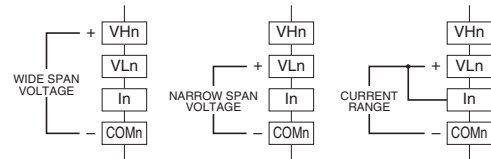

Be sure to close across VLn and In terminals for a current input.



THERMOCOUPLE INPUT MODULE, 4 points

MODEL: R7L-TS4

SPECIFICATIONS

Isolation: Input 0 to input 1 to input 2 to input 3 to power input or LonWorks or FG

Converted data range: Engineering unit value (°C)

Thermocouple: K(*), E, J, T, B, R, S, C, N, U, L, P, PR

(*): Factory setting

(T/C type is selectable using the LNS Plug-in Software

(model: R7LPLG))

Input resistance: ≥ 30 kΩ

Burnout sensing: ≤ 0.1 μA

Conversion accuracy: ±1°C (±1.8°F);

±2.0°C (±3.6°F) for B, R, S, C, PR

Conversion rate: 250 msec.

Temperature coefficient: ±0.015 %/°C (±0.008 %/°F)

CJC error: ±1.0°C at 25°C ±10°C

(±1.8°F at 77°F ±18°F)

±1.5°C (±2.7°F) for R, S, PR

T/C	BURNOUT INDICATION (°C)		CONFORMANCE RANGE (°C)
	Downscale	Upscale	
K (CA)	-272	+1472	-150 to +1370
E (CRC)	-272	+1120	-170 to +1000
J (IC)	-260	+1300	-180 to +1200
T (CC)	-272	+ 500	-170 to + 400
B (RH)	+24	1920	400 to 1760
R	-100	+1860	200 to 1760
S	-100	+1860	0 to 1760
C (WRe 5-26)	-52	+2416	0 to 2315
N	-272	+1400	-130 to +1300
U	-252	+ 700	-200 to +600
L	-252	+1000	-200 to +900
P (Platinel II)	-52	+1496	0 to 1395
(PR)	-52	+1860	0 to 1760

FUNCTIONAL BLOCKS

The following Functional Blocks are usable. Refer to the instruction manual for detailed information.

- NodeObject (extension module setting)
- fbCNT (count)
- fbTS (thermocouple input & setting)
- fbARM (alarm output)
- fbCV (scaling)
- fbLED (LED function)
- fbDOEX (discrete output, extension module)
- fbDIEX (discrete input, extension module)

TERMINAL ASSIGNMENTS

10	11	12	13	14	15	16	17	18
+IN0	-IN0	+IN1	-IN1	NC	+IN2	-IN2	+IN3	-IN3
1	2	3	4	5	6	7	8	9
+CJ0	-CJ0	+CJ1	-CJ1	NC	+CJ2	-CJ2	+CJ3	-CJ3

NO.	ID	FUNCTION	NO.	ID	FUNCTION
1	+CJ0	CJC 0	10	+IN0	T/C + 0
2	-CJ0	CJC 0	11	-IN0	T/C - 0
3	+CJ1	CJC 1	12	+IN1	T/C + 1
4	-CJ1	CJC 1	13	-IN1	T/C - 1
5	NC	No connection	14	NC	No connection
6	+CJ2	CJC 2	15	+IN2	T/C + 2
7	-CJ2	CJC 2	16	-IN2	T/C - 2
8	+CJ3	CJC 3	17	+IN3	T/C + 3
9	-CJ3	CJC 3	18	-IN3	T/C - 3

CIRCUIT DIAGRAM

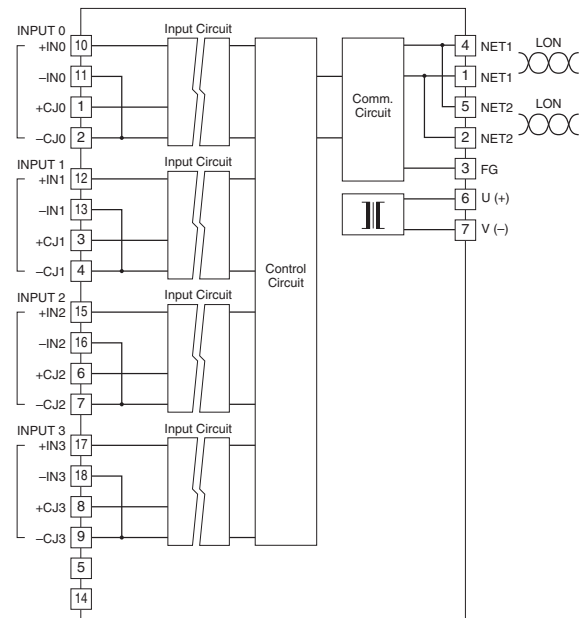

Input Connection Example

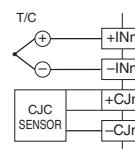

RTD INPUT MODULE, 4 points

MODEL: R7L-RS4

SPECIFICATIONS

Isolation: Input 0 to input 1 to input 2 to input 3 to power input or LonWorks or FG

Converted data range: Engineering unit value (°C)

RTD: Pt 100 (JIS '97/IEC)(*), Pt 100 (JIS '89),

JPt 100 (JIS '89), Pt 50 (JIS '81), Ni 100,

Cu 10, Cu 50

(*) Factory setting

(RTD type is selectable using the LNS Plug-in Software

(model: R7LPLG))

Sensing current: ≤ 1 mA

Input resistance: ≥ 1 MΩ

Maximum leadwire resistance: 100 Ω per wire

Conversion accuracy: ±1°C (±1.8°F);

±3°C (±5.4°F) for Cu 10

Conversion rate: 250 msec.

Temperature coefficient: ±0.015 %/°C (±0.008 %/°F)

RTD	BURNOUT INDICATION (°C)		CONFORMANCE RANGE (°C)
	Downscale	Upscale	
Pt 100 (JIS '97/IEC)	-240	+900	-200 to +850
Pt 100 (JIS '89)	-240	+900	-200 to +660
JPt 100 (JIS '89)	-236	+560	-200 to +510
Pt 50 Ω (JIS '81)	-236	+700	-200 to +649
Ni 100	-100	+252	-80 to +250
Cu 10 (25°C)	-212	+312	-50 to +250
Cu 50	-100	+200	-50 to +150

FUNCTIONAL BLOCKS

The following Functional Blocks are usable. Refer to the instruction manual for detailed information.

- NodeObject (extension module setting)
- fbCNT (count)
- fbRS (RTD input & setting)
- fbARM (alarm output)
- fbCV (scaling)
- fbLED (LED function)
- fbDOEX (discrete output, extension module)
- fbDIEX (discrete input, extension module)

TERMINAL ASSIGNMENTS

10	11	12	13	14	15	16	17	18
INA0	INb0	INA1	INb1	NC	INA2	INb2	INA3	INb3
1	2	3	4	5	6	7	8	9
NC	INB0	NC	INB1	NC	NC	INB2	NC	INB3

NO.	ID	FUNCTION	NO.	ID	FUNCTION
1	NC	No connection	10	INA0	RTD 0-A
2	INB0	RTD 0-B	11	INb0	RTD 0-b
3	NC	No connection	12	INA1	RTD 1-A
4	INB1	RTD 1-B	13	INb1	RTD 1-b
5	NC	No connection	14	NC	No connection
6	NC	No connection	15	INA2	RTD 2-A
7	INB2	RTD 2-B	16	INb2	RTD 2-b
8	NC	No connection	17	INA3	RTD 3-A
9	INB3	RTD 3-B	18	INb3	RTD 3-b

CIRCUIT DIAGRAM

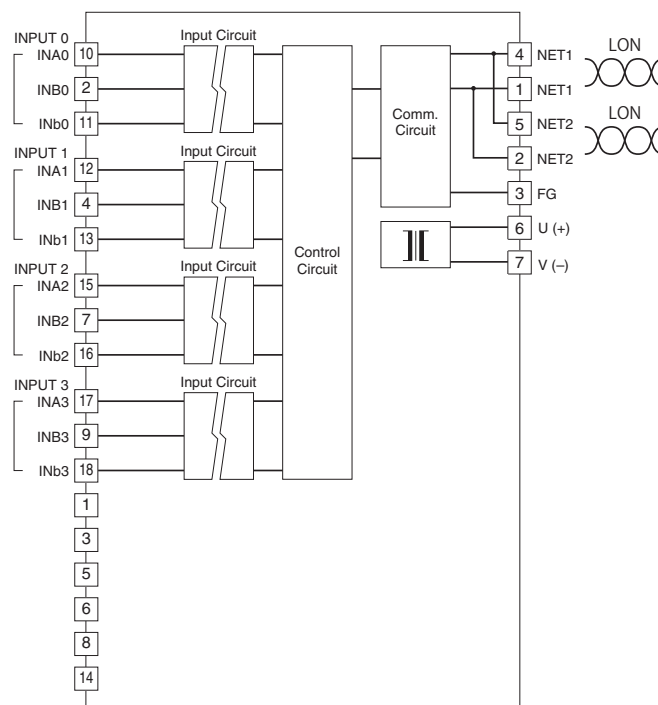

Input Connection Example

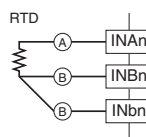

DC VOLTAGE OUTPUT MODULE, 2 points

MODEL: R7L-YV2

SPECIFICATIONS

Isolation: Output 0 to output 1 to power input or LonWorks or FG

Converted data range: 0 - 100.00 of the output range

Output range

Wide span voltage: -10 - +10 V DC(*), -5 - +5 V DC, 0 - 10 V DC, 0 - 5 V DC, 1 - 5 V DC

(*) Factory setting

Narrow span voltage: -1 - +1 V DC, 0 - 1 V DC, -0.5 - +0.5 V DC, 0 - 0.5 V DC

(Output range is selectable using the LNS Plug-in Software (model: R7LPLG))

Operational range: -15 - +115 % of the output range (except -10 - +10 V DC);

approx. -11.5 - +11.5 V DC (-10 - +10 V DC)

Load resistance: $\geq 100 \text{ k}\Omega$

Conversion accuracy: $\pm 0.1 \%$

Temperature coefficient: $\pm 0.015 \%/^{\circ}\text{C}$ ($\pm 0.008 \%/^{\circ}\text{F}$)

CIRCUIT DIAGRAM

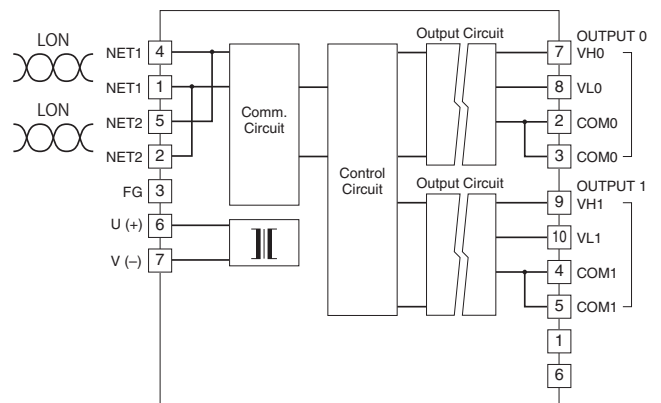

Output Connection Examples

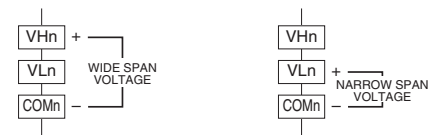

FUNCTIONAL BLOCKS

The following Functional Blocks are usable. Refer to the instruction manual for detailed information.

- NodeObject (extension module setting)
- fbCNT (count)
- fbYV (DC voltage output, output range)
- fbCV (scaling)
- fbLED (LED function)
- fbDOEX (discrete output, extension module)
- fbDIEX (discrete input, extension module)

TERMINAL ASSIGNMENTS

6	7	8	9	10
NC	VH0	VL0	VH1	VL1
1	2	3	4	5
NC	COM0	COM0	COM1	COM1

NO.	ID	FUNCTION	NO.	ID	FUNCTION
1	NC	No connection	6	NC	No connection
2	COM0	Common 0	7	VH0	Wide span volt. 0
3	COM0	Common 0	8	VL0	Narrow span volt. 0
4	COM1	Common 1	9	VH1	Wide span volt. 1
5	COM1	Common 1	10	VL1	Narrow span volt. 1



DC CURRENT OUTPUT MODULE, 2 points

MODEL: R7L-YS2

SPECIFICATIONS

Isolation: Output 0 to output 1 to power input or LonWorks or FG

Converted data range: 0 - 100.00 of the output range

Output range: 4 - 20 mA DC

Load resistance: ≤ 600Ω

Conversion accuracy: ±0.1 %

Temperature coefficient: ±0.015 %/°C (±0.008 %/°F)

FUNCTIONAL BLOCKS

The following Functional Blocks are usable. Refer to the instruction manual for detailed information.

- NodeObject (extension module setting)
- fbCNT (count)
- fbYS (DC current output)
- fbCV (scaling)
- fbLED (LED function)
- fbDOEX (discrete output, extension module)
- fbDIEX (discrete input, extension module)

TERMINAL ASSIGNMENTS

6	7	8	9	10
NC	I0	NC	I1	NC
1	2	3	4	5
NC	COM0	NC	COM1	NC

NO.	ID	FUNCTION	NO.	ID	FUNCTION
1	NC	No connection	6	NC	No connection
2	COM0	Common 0	7	I0	Current 0
3	NC	No connection	8	NC	No connection
4	COM1	Common 1	9	I1	Current 1
5	NC	No connection	10	NC	No connection

CIRCUIT DIAGRAM

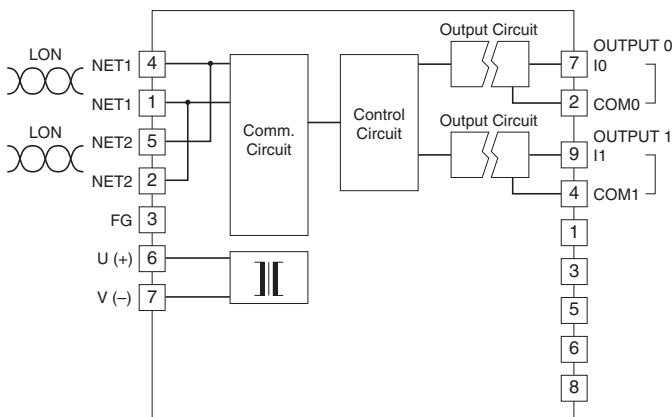

REMOTE CONTROL RELAY CONTROL MODULE

MODEL: R7L-RR8

SPECIFICATIONS

- Common:** Common per all points
- Number of I/O:** Output, 8 points
- Maximum outputs applicable at once:** No limit
- I/O status indicator:** LED turns on with closed contact.
- Isolation:** Output to LonWorks or FG or power
- Rated load voltage:** 24 V AC $\pm 10\%$ (supplied by the remote control transformer)
- Load voltage frequency:** 50 / 60 Hz

FUNCTIONAL BLOCKS

The following Functional Blocks are usable. Refer to the instruction manual for detailed information.

- NodeObject (extension module setting)
- fbCMP (compare)
- fbRR (remote control relay control output)
- fbDOEX (discrete output, extension module)
- fbDIEX (discrete input, extension module)

TERMINAL ASSIGNMENTS

10	11	12	13	14	15	16	17	18
NC	Y0	Y1	Y2	Y3	Y4	Y5	Y6	Y7
1	2	3	4	5	6	7	8	9
NC	C0	C1	C2	C3	C4	C5	C6	C7

NO.	ID	FUNCTION	NO.	ID	FUNCTION
1	NC	No connection	10	NC	No connection
2	C0	Common	11	Y0	Output 0
3	C1	Common	12	Y1	Output 1
4	C2	Common	13	Y2	Output 2
5	C3	Common	14	Y3	Output 3
6	C4	Common	15	Y4	Output 4
7	C5	Common	16	Y5	Output 5
8	C6	Common	17	Y6	Output 6
9	C7	Common	18	Y7	Output 7

CIRCUIT DIAGRAM

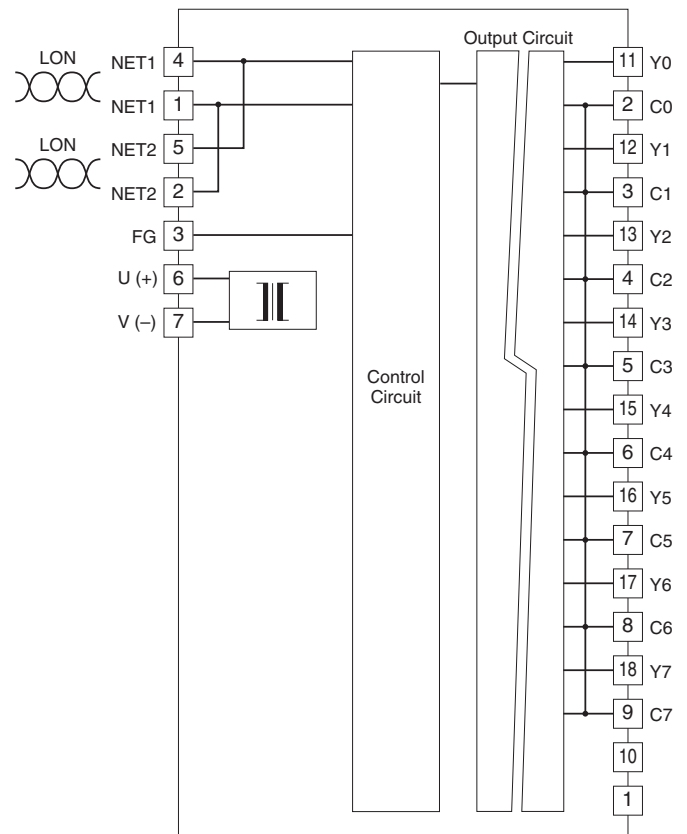

Output Connection Example

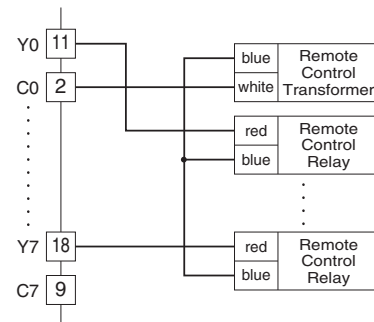

DISCRETE INPUT EXTENSION MODULE, 8 points

CIRCUIT DIAGRAM

MODEL: R7L-EA8

SPECIFICATIONS

Common: Positive or negative common (NPN/PNP) per 8 points

Number of I/O: Input, 8 points

Maximum inputs applicable at once: No limit (at 24 V DC)

I/O status indicator: LED turns on with closed contact.

Isolation: Input to internal circuits

Rated input voltage: 24 V DC $\pm 10\%$; ripple 5 %p-p max.

ON voltage / current: ≥ 15 V DC (input - COM) / ≥ 3.5 mA

OFF voltage / current: ≤ 5 V DC (input - COM) / ≤ 1 mA

Input current: ≤ 5.5 mA per point at 24 V DC

Input resistance: Approx. 4.4 k Ω

TERMINAL ASSIGNMENTS

6	7	8	9	10
NC	X1	X3	X5	X7
1	2	3	4	5
COM	X0	X2	X4	X6

NO.	ID	FUNCTION	NO.	ID	FUNCTION
1	COM	Common	6	NC	No Connection
2	X0	Input 0	7	X1	Input 1
3	X2	Input 2	8	X3	Input 3
4	X4	Input 4	9	X5	Input 5
5	X6	Input 6	10	X7	Input 7

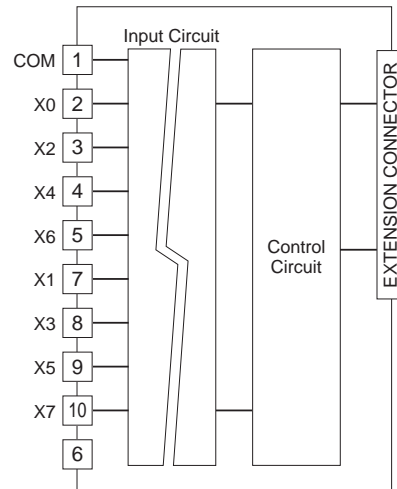

Input Circuit

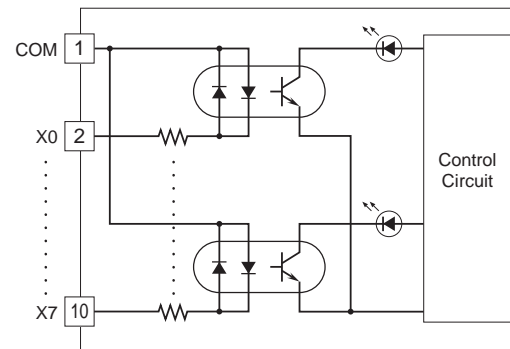

Input Connection Examples

PNP Connection

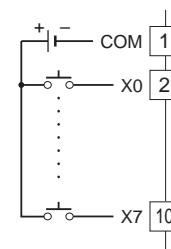

NPN Connection

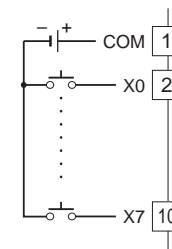

DISCRETE INPUT EXTENSION MODULE, 16 points

CIRCUIT DIAGRAM

MODEL: R7L-EA16

SPECIFICATIONS

Common: Positive or negative common (NPN/PNP) per 16 points

Number of I/O: Input, 16 points

Maximum inputs applicable at once: No limit (at 24 V DC)

I/O status indicator: LED turns on with closed contact.

Isolation: Input to internal circuits

Rated input voltage: 24 V DC $\pm 10\%$; ripple 5 %p-p max.

ON voltage / current: ≥ 15 V DC (input - COM) / ≥ 3.5 mA

OFF voltage / current: ≤ 5 V DC (input - COM) / ≤ 1 mA

Input current: ≤ 5.5 mA per point at 24 V DC

Input resistance: Approx. 4.4 k Ω

TERMINAL ASSIGNMENTS

10	11	12	13	14	15	16	17	18
NC	X1	X3	X5	X7	X9	XB	XD	XF
1	2	3	4	5	6	7	8	9
COM	X0	X2	X4	X6	X8	XA	XC	XE

NO.	ID	FUNCTION	NO.	ID	FUNCTION
1	COM	Common	10	NC	No Connection
2	X0	Input 0	11	X1	Input 1
3	X2	Input 2	12	X3	Input 3
4	X4	Input 4	13	X5	Input 5
5	X6	Input 6	14	X7	Input 7
6	X8	Input 8	15	X9	Input 9
7	XA	Input 10	16	XB	Input 11
8	XC	Input 12	17	XD	Input 13
9	XE	Input 14	18	XF	Input 15

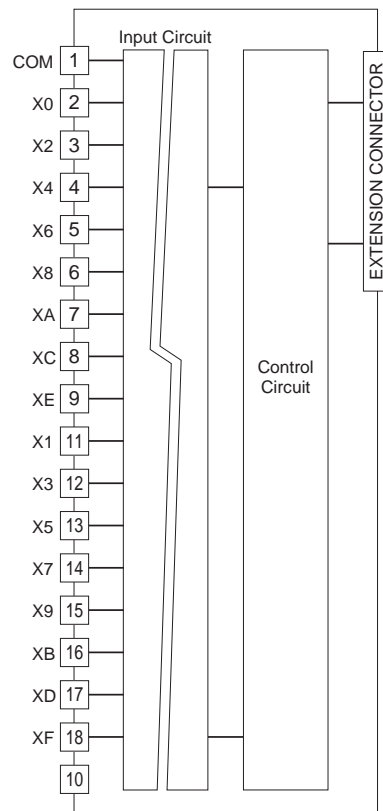

Input Circuit

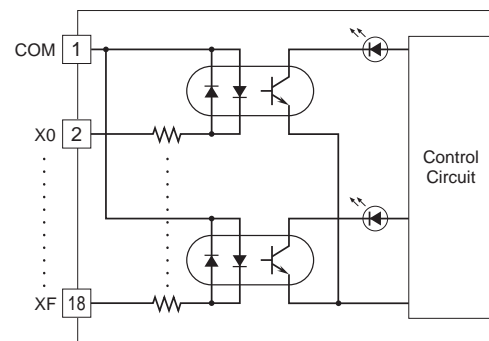

Input Connection Examples

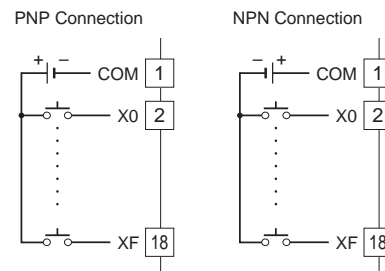

NPN TRANSISTOR OUTPUT EXTENSION MODULE, 8 points

CIRCUIT DIAGRAM

MODEL: R7L-EC8A

SPECIFICATIONS

- Common:** Negative common (NPN) per 8 points
- Number of I/O:** Output, 8 points
- Maximum outputs applicable at once:** No limit (at 24 V DC)
- I/O status indicator:** LED turns on with closed contact.
- Isolation:** Output to internal circuits
- Rated load voltage:** 24 V DC $\pm 10\%$
- Rated output current:** 0.25 A per point, 2.0 A per common
- Residual voltage:** ≤ 1.2 V
- Leakage current:** ≤ 0.1 mA

TERMINAL ASSIGNMENTS

6	7	8	9	10
+24 V	Y1	Y3	Y5	Y7
1	2	3	4	5
0 V	Y0	Y2	Y4	Y6

NO.	ID	FUNCTION	NO.	ID	FUNCTION
1	0 V	0 V (common)	6	+24 V	24 V DC
2	Y0	Output 0	7	Y1	Output 1
3	Y2	Output 2	8	Y3	Output 3
4	Y4	Output 4	9	Y5	Output 5
5	Y6	Output 6	10	Y7	Output 7

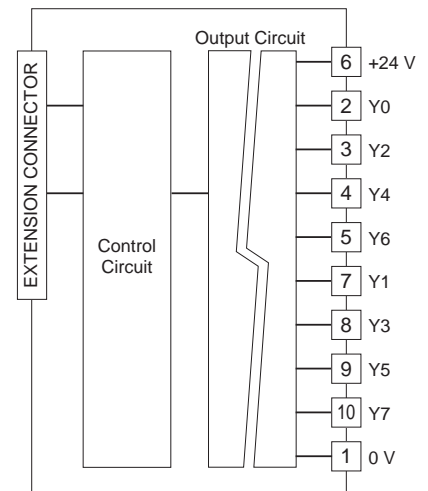

Output Circuit

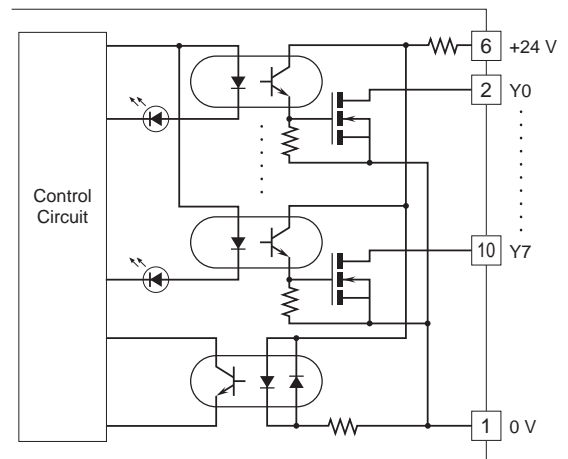

Output Connection Example

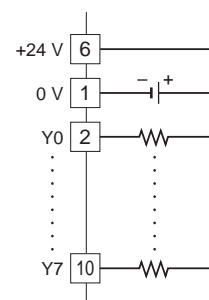

NPN TRANSISTOR OUTPUT EXTENSION MODULE, 16 points

CIRCUIT DIAGRAM

MODEL: R7L-EC16A

SPECIFICATIONS

- Common:** Negative common (NPN) per 16 points
- Number of I/O:** Output, 16 points
- Maximum outputs applicable at once:** No limit (at 24 V DC)
- I/O status indicator:** LED turns on with closed contact.
- Isolation:** Output to internal circuits
- Rated load voltage:** 24 V DC $\pm 10\%$
- Rated output current:** 0.25 A per point, 2.0 A per common
- Residual voltage:** ≤ 1.2 V
- Leakage current:** ≤ 0.1 mA

TERMINAL ASSIGNMENTS

10	11	12	13	14	15	16	17	18
+24 V	Y1	Y3	Y5	Y7	Y9	YB	YD	YF
1	2	3	4	5	6	7	8	9
0 V	Y0	Y2	Y4	Y6	Y8	YA	YC	YE

NO.	ID	FUNCTION	NO.	ID	FUNCTION
1	0 V	0 V (common)	10	+24 V	24 V DC
2	Y0	Output 0	11	Y1	Output 1
3	Y2	Output 2	12	Y3	Output 3
4	Y4	Output 4	13	Y5	Output 5
5	Y6	Output 6	14	Y7	Output 7
6	Y8	Output 8	15	Y9	Output 9
7	YA	Output 10	16	YB	Output 11
8	YC	Output 12	17	YD	Output 13
9	YE	Output 14	18	YF	Output 15

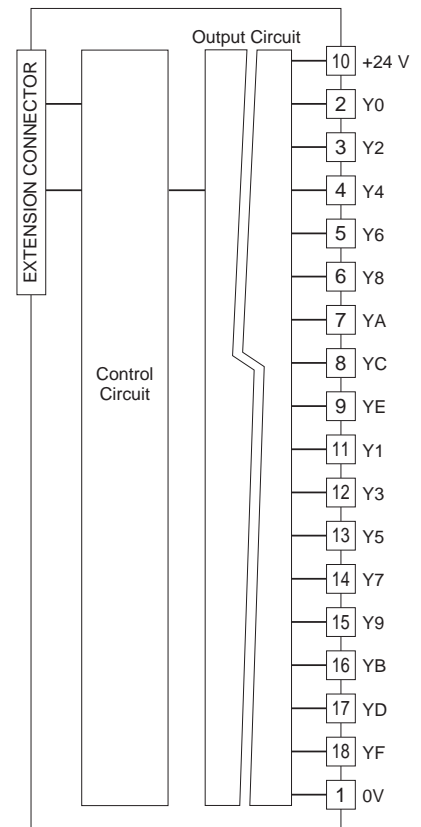

Output Circuit

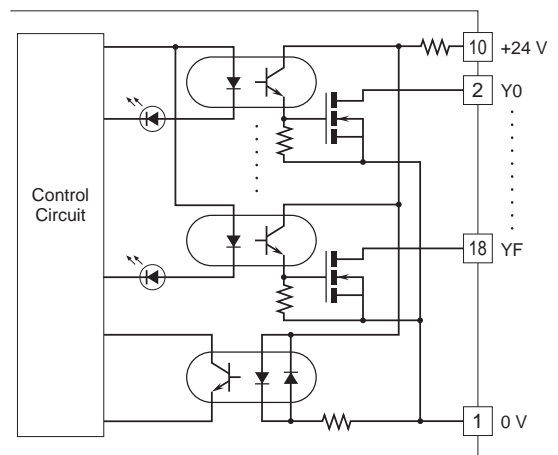

Output Connection Example

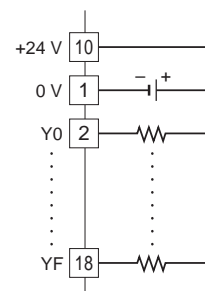

PNP TRANSISTOR OUTPUT EXTENSION MODULE, 8 points

CIRCUIT DIAGRAM

MODEL: R7L-EC8B

SPECIFICATIONS

- Common:** Positive common (PNP) per 8 points
- Number of I/O:** Output, 8 points
- Maximum outputs applicable at once:** No limit (at 24 V DC)
- I/O status indicator:** LED turns on with closed contact.
- Isolation:** Output to internal circuits
- Rated load voltage:** 24 V DC $\pm 10\%$
- Rated output current:** 0.25 A per point, 2.0 A per common
- Residual voltage:** ≤ 1.2 V
- Leakage current:** ≤ 0.1 mA

TERMINAL ASSIGNMENTS

6	7	8	9	10
+24 V	Y1	Y3	Y5	Y7
1	2	3	4	5
0 V	Y0	Y2	Y4	Y6

NO.	ID	FUNCTION	NO.	ID	FUNCTION
1	0 V	0 V	6	+24 V	24 V DC (common)
2	Y0	Output 0	7	Y1	Output 1
3	Y2	Output 2	8	Y3	Output 3
4	Y4	Output 4	9	Y5	Output 5
5	Y6	Output 6	10	Y7	Output 7

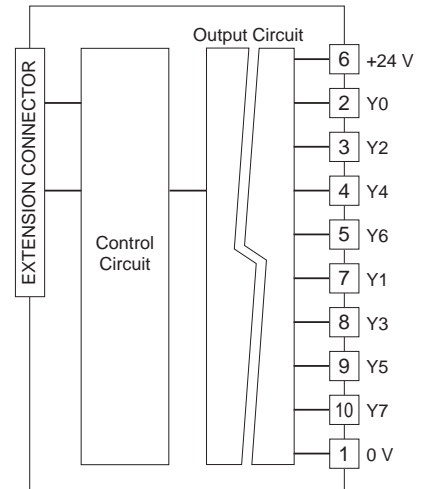

Output Circuit

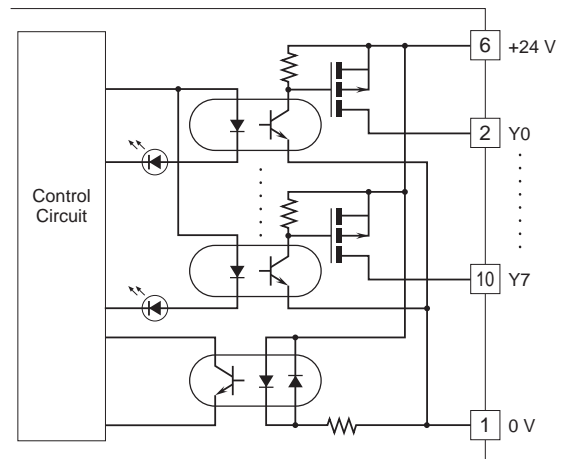

Output Connection Example

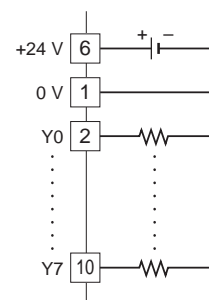

PNP TRANSISTOR OUTPUT EXTENSION MODULE, 16 points

CIRCUIT DIAGRAM

MODEL: R7L-EC16B

SPECIFICATIONS

- Common:** Positive common (PNP) per 16 points
- Number of I/O:** Output, 16 points
- Maximum outputs applicable at once:** No limit (at 24 V DC)
- I/O status indicator:** LED turns on with closed contact.
- Isolation:** Output to internal circuits
- Rated load voltage:** 24 V DC $\pm 10\%$
- Rated output current:** 0.25 A per point, 2.0 A per common
- Residual voltage:** ≤ 1.2 V
- Leakage current:** ≤ 0.1 mA

TERMINAL ASSIGNMENTS

10	11	12	13	14	15	16	17	18
+24 V	Y1	Y3	Y5	Y7	Y9	YB	YD	YF
1	2	3	4	5	6	7	8	9
0 V	Y0	Y2	Y4	Y6	Y8	YA	YC	YE

NO.	ID	FUNCTION	NO.	ID	FUNCTION
1	0 V	0 V	10	+24 V	24 V DC (common)
2	Y0	Output 0	11	Y1	Output 1
3	Y2	Output 2	12	Y3	Output 3
4	Y4	Output 4	13	Y5	Output 5
5	Y6	Output 6	14	Y7	Output 7
6	Y8	Output 8	15	Y9	Output 9
7	YA	Output 10	16	YB	Output 11
8	YC	Output 12	17	YD	Output 13
9	YE	Output 14	18	YF	Output 15

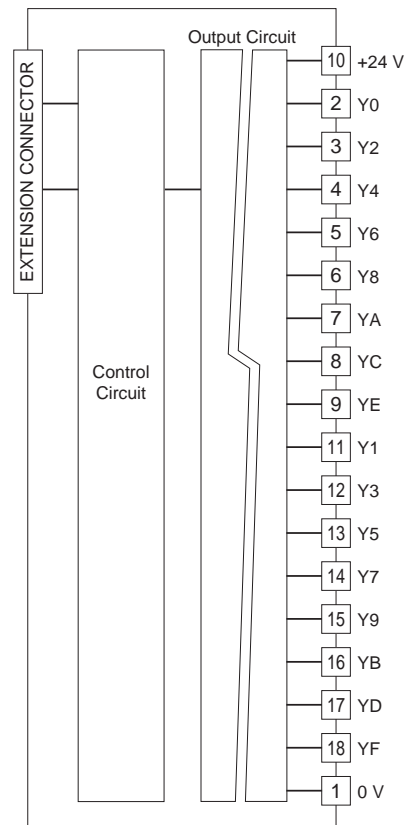

Output Circuit

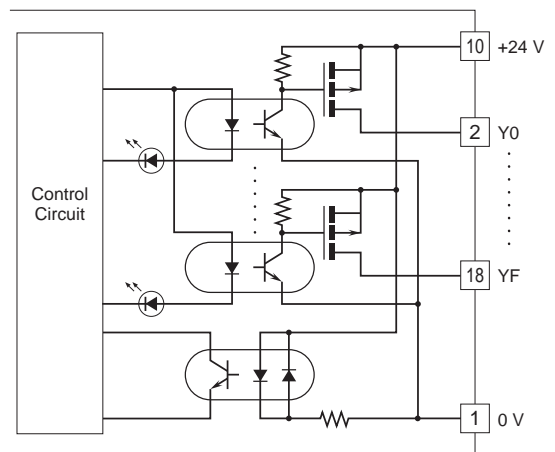

Output Connection Example

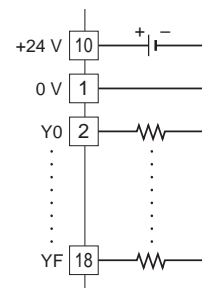



Specifications are subject to change without notice.



幸託有限公司
XIN TOP CORPORATION

TEL : (02)2598-1199
FAX : (02)2596-2331

E-mail : info@xintop.com
Website : www.xintop.com