

## Remote I/O R7 Series

### GATEWAY MODULE

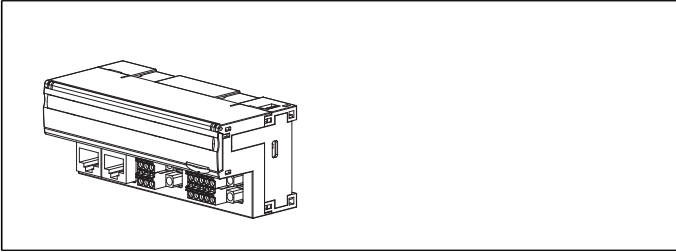

### MODEL: R7G-SC-S[1]-R

#### ORDERING INFORMATION

- Code number: R7G-SC-S[1]-R  
Specify a code from below for [1]  
(e.g. R7G-SC-SHL-R)

#### Module type of network 1

S: Slave

#### Type of network 1

C: CC-Link

#### Module type of network 2

S: Slave

#### [1] Type of network 2

HL: HLS (Hi-speedLink System) Full-duplex  
HL1: HLS (Hi-speedLink System) Half-duplex

#### POWER INPUT

DC Power  
R: 24 V DC

#### FUNCTIONS & FEATURES

The Gateway Module for CC-Link and HLS (Hi-speedLink System) connects discrete I/O between the networks each other. The module hands over 32 point inputs of CC-Link to 32 point outputs of HLS or 32 point inputs of HLS to 32 point outputs of CC-Link.

#### CAUTION

In this module, the transmission between CC-Link and HLS is not synchronized. Therefore, if one of the networks read the transmitted data before completion of its update by the other network, the data may be uncertain as 16-bit data. If

the correct 16-bit data is necessary, arrange the host application program.  
Refer to the instruction manual.

#### GENERAL SPECIFICATIONS

##### Connection

- **Power supply, CC-Link:** Screwless spring terminal

**Applicable wire size:** 0.2 - 1.25 mm<sup>2</sup>

**Stripped length:** 10 mm

##### Recommended solderless terminal

A10,25-12BU 0.25 mm<sup>2</sup> (Phoenix Contact)

A10,34-12TQ 0.34 mm<sup>2</sup> (Phoenix Contact)

A10,5-10WH 0.5 mm<sup>2</sup> (Phoenix Contact)

A10,75-10GY 0.75 mm<sup>2</sup> (Phoenix Contact)

A1-10 1.0 mm<sup>2</sup> (Phoenix Contact)

A1.5-10 1.5 mm<sup>2</sup> (Phoenix Contact)

- **HLS:** RJ-45 Connectors

##### Recommended cable connector:

TM21P-88P (Hirose Electric)

(not included in the package)

**Isolation:** CC-Link or FG to HLS to power

**Module address:** Rotary switch

(For the detail refer to the instruction manual.)

##### Transfer rate

- **CC-Link** Rotary switch

- **HLS** DIP switch

(For the detail refer to the instruction manual.)

**Power LED:** Green light turns on when the power is supplied.

##### Status indicator LED

- **CC-Link:** Red LEDs indicate communication status.

- **HLS:** Green LEDs indicate communication status.

#### COMMUNICATION

##### ■ HLS COMMUNICATION

**Network:** Full-duplex or half-duplex

**Transmission distance:**

- **12 Mbps:** 100 meters (328 ft)

- **6 Mbps:** 200 meters (656 ft)

**Network cable:**

- **Full-duplex communication:** ZHY262PS, ZHT262PS

- **Half-duplex communication:** ZHY221PS

(Shinko Seisen Industry Co., Ltd.)

**Data allocation:** 2

##### ■ CC-LINK COMMUNICATION

CC-LinkVer.1.10

**Network cable:** CC-Link cable designated by Mitsubishi

Electric

**Station Type:** Remote I/O

**Data allocation:** 2 (1 station x 2)



## INSTALLATION

### Power input

#### •DC:

Operational voltage range 24 V DC  $\pm 10\%$  ;

ripple 10 %p-p max., approx. 1.8 W

**Operating temperature:** -10 to +55°C (14 to 131°F)

**Storage temperature:** -20 to +65°C (-4 to +149°F)

**Operating humidity:** 30 to 90 %RH (non-condensing)

**Atmosphere:** No corrosive gas or heavy dust

**Mounting:** DIN rail

**Weight:** 150 g (0.33 lbs)

## PERFORMANCE

**Insulation resistance:**  $\geq 100\text{ M}\Omega$  with 500 V DC

**Dielectric strength:** 1500 V AC @1 minute

(CC-Link or FG to HLS to power)

## EXTERNAL VIEW

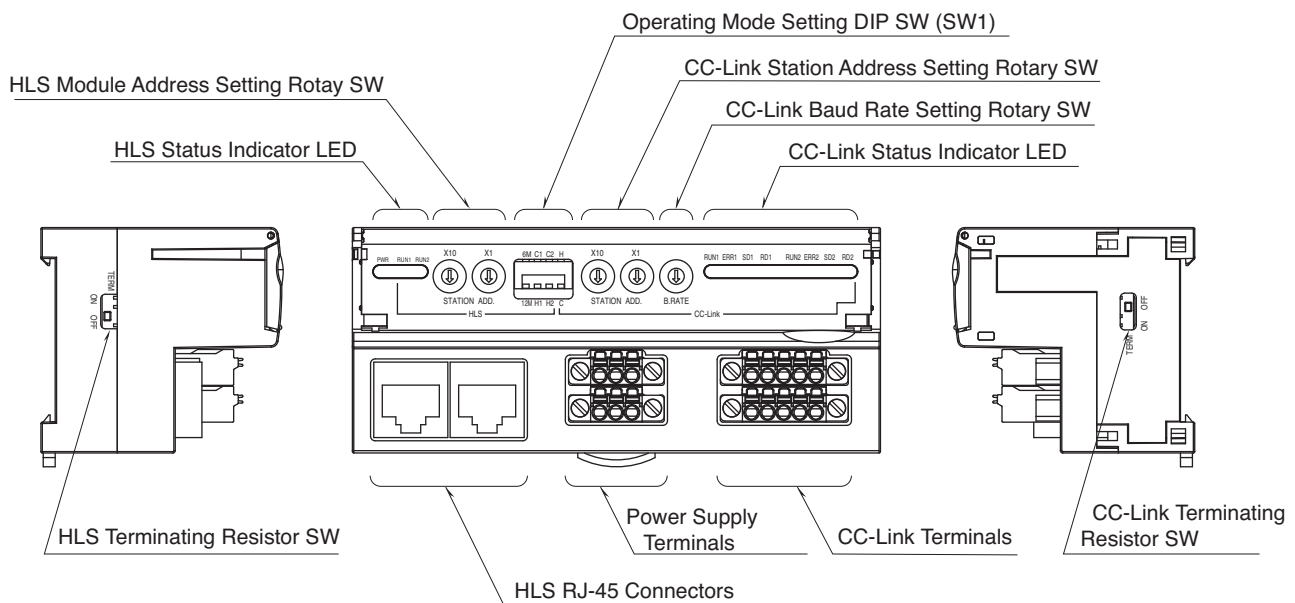

## CONNECTION DIAGRAMS

### POWER SUPPLY AND TRANSMISSION WIRING

#### Power supply

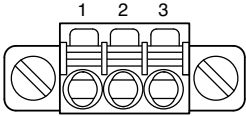

- 1. +24V Power Supply (24V DC)
- 2. 0V Power Supply (0V)
- 3. FG FG

#### CC-Link

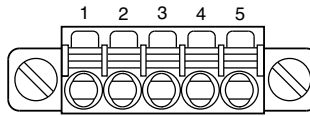

- 1. DA blue
- 2. DB white
- 3. DG yellow
- 4. SLD Shield
- 5. FG FG

#### HLS

#### Full-duplex communication

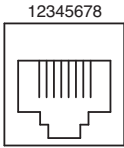

- 1. NC No connection
- 2. NC No connection
- 3. TXD+ Network (Slave, transmission +)
- 4. TXD- Network (Slave, transmission -)
- 5. RXD+ Network (Master, transmission+)
- 6. RXD- Network (Master, transmission-)
- 7. NC No connection
- 8. SLD1 Shield

#### Half-duplex communication

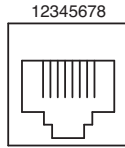

- 1. NC No connection
- 2. NC No connection
- 3. TR+ Network (+)
- 4. TR- Network (-)
- 5. NC No connection
- 6. NC No connection
- 7. NC No connection
- 8. SLD1 Shield

### Master Module wiring

#### CC-Link

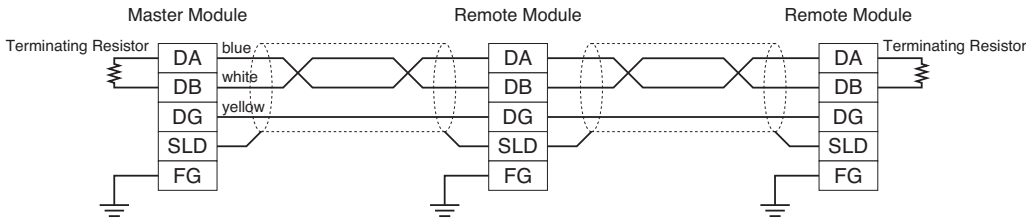

#### HLS

#### Full-duplex communication

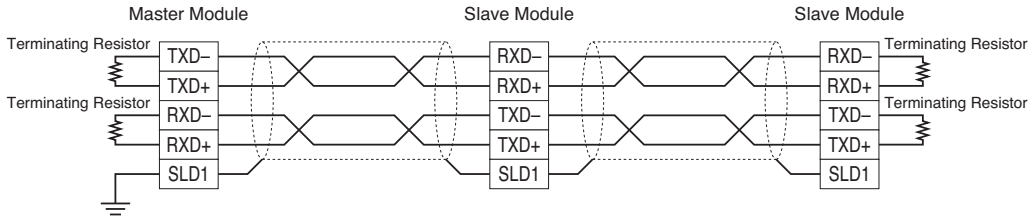

#### Half-duplex communication

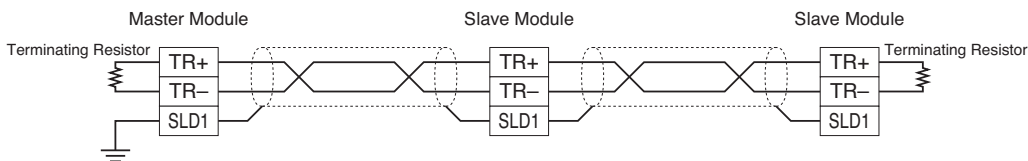

**INDICATOR LED**

■ **CC-Link STATUS INDICATOR LED**

RUN	ERR	SD	RD	STATUS
ON	BL	BL	ON	Communicates normally with occasional CRC errors due to noise interference.
ON	BL	BL	ON	Communicates normally but the Baud Rate and/or Station Address switches failed. ERR LED blinks approximately in 0.5 second intervals.
ON	BL	BL	OFF	----
ON	BL	OFF	ON	CRC error found in the received data. Unable to respond.
ON	BL	OFF	OFF	----
ON	OFF	BL	ON	Normal communication
ON	OFF	BL	OFF	----
ON	OFF	OFF	ON	Unable to receive data addressed to the station.
ON	OFF	OFF	OFF	----
OFF	BL	BL	ON	Performs the interval-timed responses but CRC error found in receiving the refresh data.
OFF	BL	BL	OFF	----
OFF	BL	OFF	ON	CRC error found in the data addressed to the station.
OFF	BL	OFF	OFF	----
OFF	OFF	BL	ON	Link is not started.
OFF	OFF	BL	OFF	----
OFF	OFF	OFF	ON	No data addressed to the station. Or unable to receive data addressed to the station due to noise interference. (Missing parts of the data sent from the master)
OFF	OFF	OFF	OFF	Unable to receive data due to wire breakdown
OFF	ON	OFF	OFF/ON	Faulty Baud Rate and/or Station Address setting
OFF	OFF	OFF	OFF	Power input removed. Or power supply failure.

OFF = OFF, ON = ON, BL = Blinking  
 ---- = Inconceivable in normal operations (e.g. LED failure)

**DATA ALLOCATION**

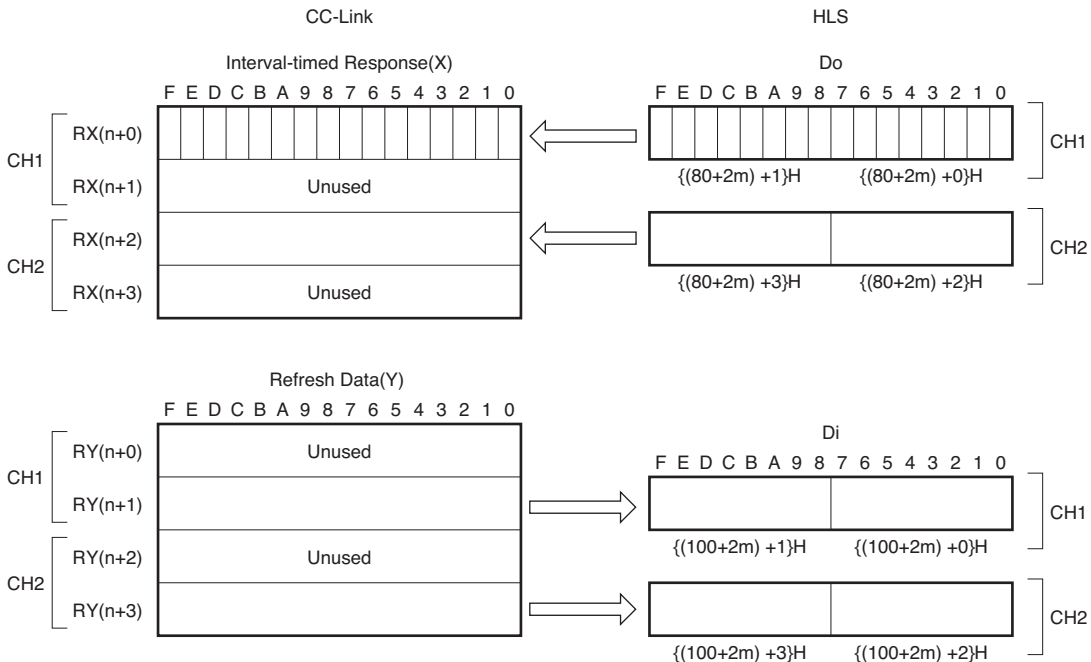

n: CC-Link station address selected with rotary SW.  
 m: HLS module address selected with rotary SW.



**I/O DATA DESCRIPTIONS**

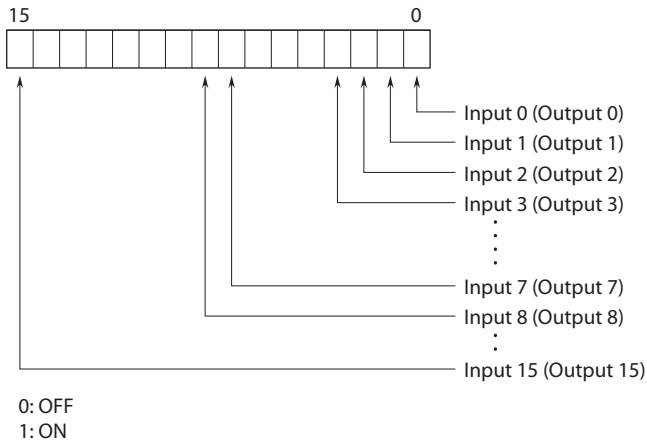

**DIMENSIONS unit: mm (inch)**

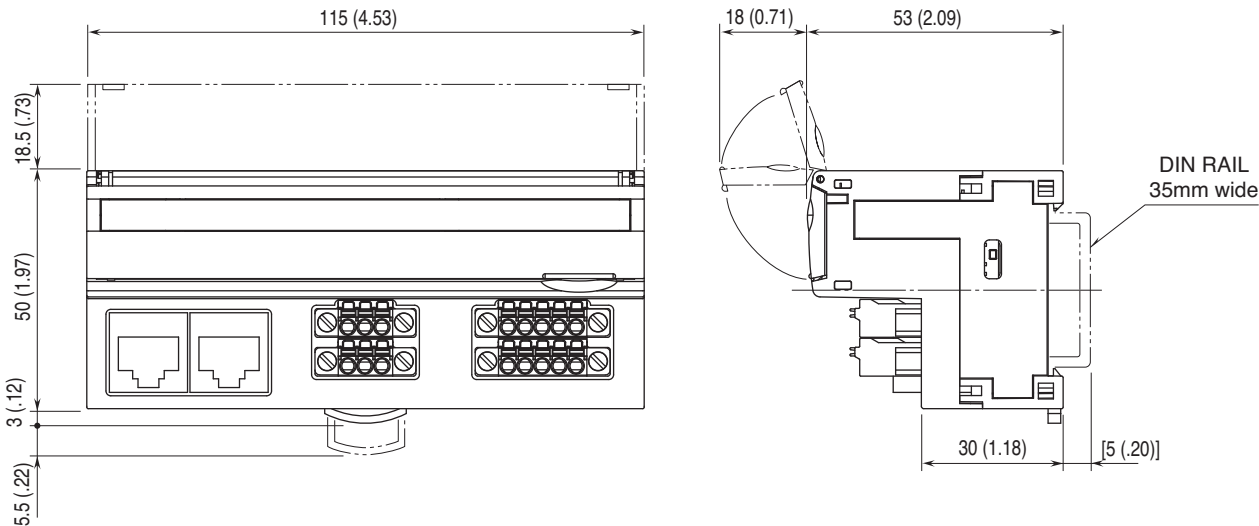

**SCHEMATIC CIRCUITRY & CONNECTION DIAGRAM**

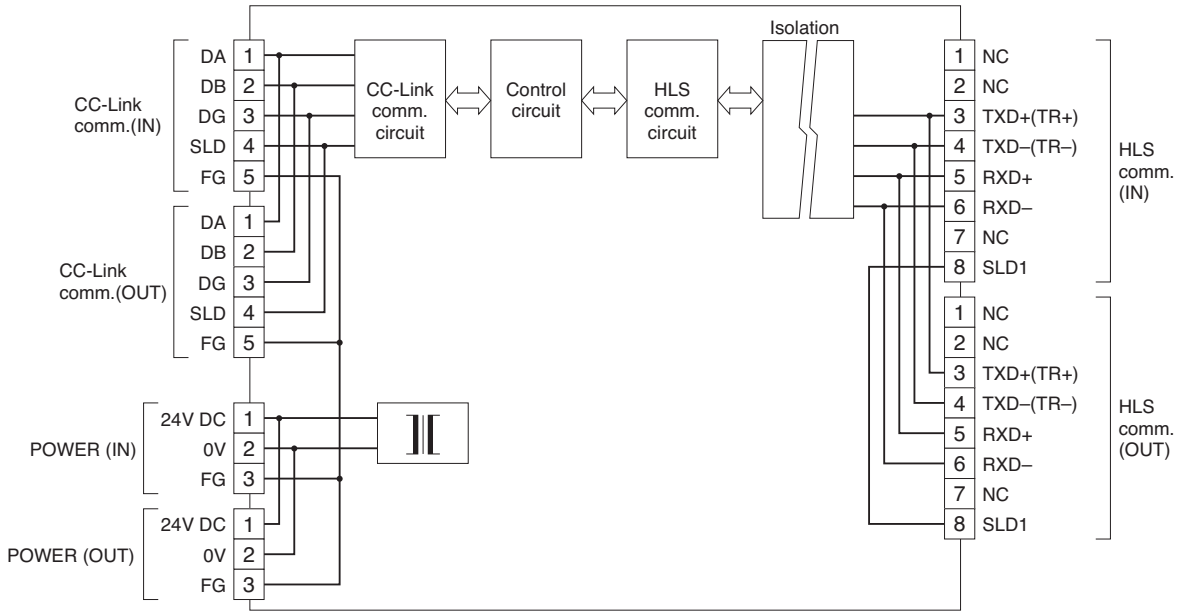

**SYSTEM CONFIGURATION EXAMPLES**

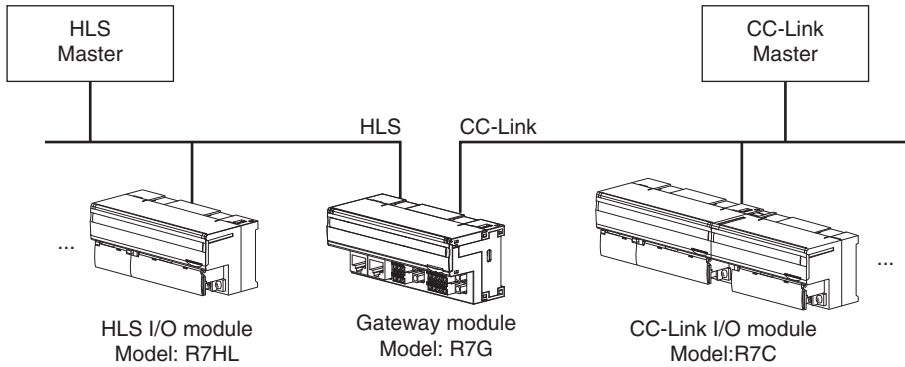

Specifications are subject to change without notice.

