

Remote I/O R7 Series

FLEX NETWORK I/O MODULE

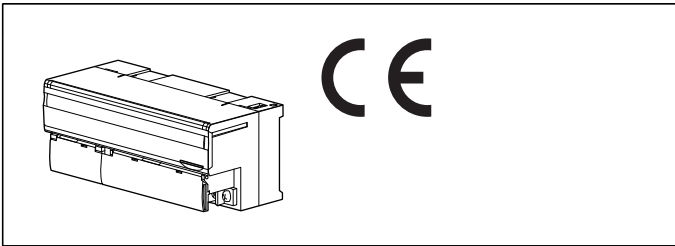

ORDERING INFORMATION

- Basic module: R7FN-[1]-R[2]
Specify a code from below for each [1] and [2].
(e.g. R7FN-DC16A-R/Q)
- Specify the specification for option code /Q
(e.g. /SET)

MODEL: R7FN-[1]-R[2]

[1] I/O TYPE

- DA16:** Discrete input, 16 points
- DC16A:** NPN transistor output, 16 points
- DC16B:** PNP transistor output, 16 points
- DAC16A:** Discrete input, 8 points
NPN transistor output, 8 points
- DAC16B:** Discrete input, 8 points
PNP transistor output, 8 points
- DC8C:** Relay contact output, 8 points
- SV4:** DC voltage/current input (10 V/20 mA), 4 points
- SVF4:** DC voltage/current input (10 V/20 mA), high speed,
4 points, non-isolated (CE not available)
- TS4:** Thermocouple input, 4 points
- RS4:** RTD input, 4 points
- YV2:** DC voltage output, 2 points
- YS2:** DC current output, 2 points

POWER INPUT

- DC Power**
- R: 24 V DC

[2] OPTIONS

- blank: none
- /Q: With options (specify the specification)

SPECIFICATIONS OF OPTION: Q

EX-FACTORY SETTING

- /SET: Preset according to the Ordering Information Sheet
(No. ESU-7808-x)

FUNCTIONS & FEATURES

The R7FN interfaces discrete I/O signals with a PLC via FLEX NETWORK.

Input sensor type (thermocouple, RTD) and range can be selected with the front DIP switches for all channels. In order to set different selections for individual channels, the PC Configurator Software (model: R7CON) is used. The analog modules are compatible with the screen editor GP-Pro EX (Ver. 2.70 or later). For versions between 2.60 and 2.70, the driver must be installed. The driver is downloadable at Digital Electronics Corporation's web site.
<http://www.proface.co.jp/>

FLEX NETWORK is registered trademark of Digital Electronics Corporation in Japan.

RELATED PRODUCTS

- PC configurator software (model: R7CON)
Downloadable at M-System's web site.
A dedicated cable is required to connect the module to the PC. Please refer to the internet software download site or the users manual for the PC configurator for applicable cable types.

GENERAL SPECIFICATIONS

- **Common Specifications**
- Power input:** 24 V DC $\pm 10\%$
- Insulation resistance:** $\geq 100\text{ M}\Omega$ with 500 V DC
- Dielectric strength:** 1500 V AC @1 minute
(Refer to each model for isolated sections.)
- Operating temperature:** -10 to +55°C (14 to 131°F)
- Operating humidity:** 30 to 90 %RH (non-condensing)
- Atmosphere:** No corrosive gas or heavy dust
- Storage temperature:** -20 to +65°C (-4 to +149°F)
- Mounting:** DIN rail (35 mm wide)
- Connection:** M3 screw terminals (torque 0.5 N·m)
- Screw terminal material:** Nickel-plated steel
- Recommended solderless terminal:**
Communication cable: Applicable wire size 0.2 to 0.5 mm²
(AWG26 - 22)
Recommended manufacturer: Japan Solderless Terminal MFG.Co.Ltd
Others: 0.25 to 1.65 mm² (AWG 22 to 16)
Recommended manufacturer: Japan Solderless Terminal MFG.Co.Ltd, Nichifu Co.,Ltd
- Status indicator LEDs:** PWR, RUN (Refer to the instruction manual for details)
- **Current Consumption & Weight**
- R7FN-DA16: Approx. 50 mA, 200 g (0.44 lb)
- R7FN-DC16A: Approx. 50 mA, 200 g (0.44 lb)
- R7FN-DC16B: Approx. 50 mA, 200 g (0.44 lb)
- R7FN-DAC16A: Approx. 50 mA, 200 g (0.44 lb)



R7FN-DAC16B: Approx. 50 mA, 200 g (0.44 lb)

R7FN-DC8C: Approx. 50 mA (approx. 60 mA*),
200 g (0.44 lb)

R7FN-SV4: Approx. 90 mA, 200 g (0.44 lb)

R7FN-SVF4: Approx. 90 mA, 200 g (0.44 lb)

R7FN-TS4: Approx. 90 mA, 200 g (0.44 lb)

R7FN-RS4: Approx. 90 mA, 200 g (0.44 lb)

R7FN-YV2: Approx. 100 mA, 200 g (0.44 lb)

R7FN-YS2: Approx. 140 mA, 200 g (0.44 lb)

* Relay driving current.

■ Recommended solderless terminal

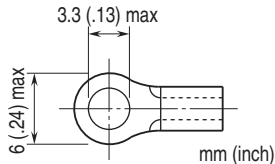

FLEX NETWORK COMMUNICATION

Communication configuration: 1: N

Connection method: Multi-drop Connection

Communication method: Cyclic Time Division, half-duplex

Communication I/F: Differential, pulse transfer isolation

Error Check: Format, bit, CRC-12 verification

Max. Number of Nodes: 63 (1008 I/O points)

Network cable: Pro-face's following cable

FN-CABLE2010-31-MS (10 m)

FN-CABLE2050-31-MS (50 m)

FN-CABLE2200-31-MS (200 m)

Transmission distance: 12 Mbps: 100 meters (328 ft)

6 Mbps: 200 meters (656 ft)

Station address: Rotary switch

(Refer to the instruction manual)

Terminating resistor: Built-in

STANDARDS & APPROVALS

CE conformity:

EMC Directive (2004/108/EC)

EMI EN 61000-6-4: 2007/A1: 2011

EMS EN 61000-6-2: 2005

(Confirm approvals availability on the model's code)

Low Voltage Directive (2006/95/EC)

(R7FN-DC8C only. Refer to the instruction manual for the detail.)

EN 61010-1: 2001

Measurement Category II

Pollution Degree 2

Output to power: Basic insulation (300 V)



EXTERNAL VIEW

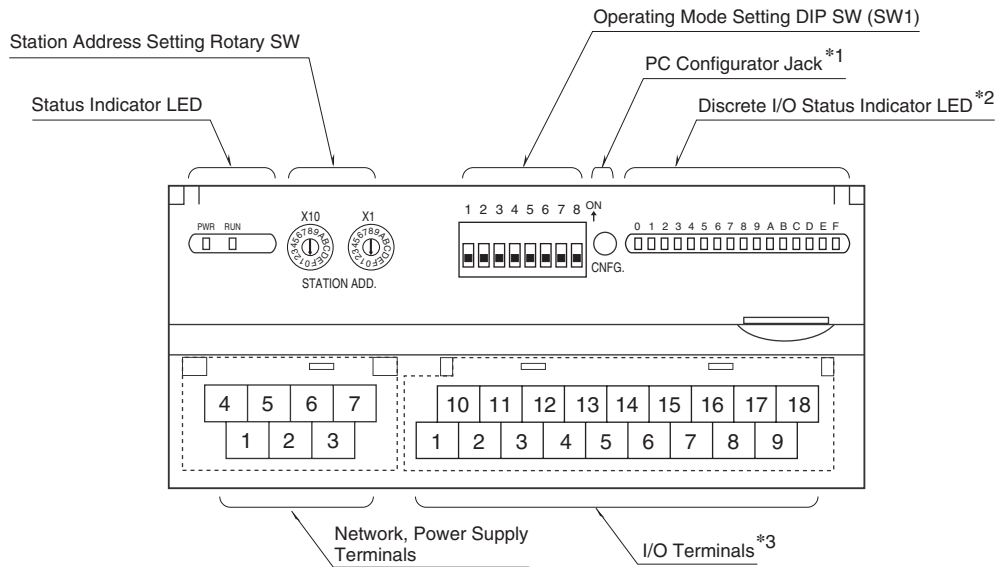

*1. Not available with discrete I/O modules.

*2. Not available with analog I/O modules. LED 8 through F are not available for 8-point discrete output modules.

*3. 10-pin terminal block available with analog output modules.

CONNECTION DIAGRAMS

NETWORK, POWER SUPPLY TERMINAL ASSIGNMENT

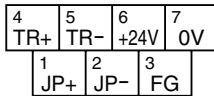

NO.	ID	FUNCTION, NOTES
1	JP+	Terminating resistor
2	JP-	Terminating resistor
3	FG	FG
4	TR+	Network
5	TR-	Network
6	+24V	Power input (24V DC)
7	0V	Power input (0V)

MASTER CONNECTION

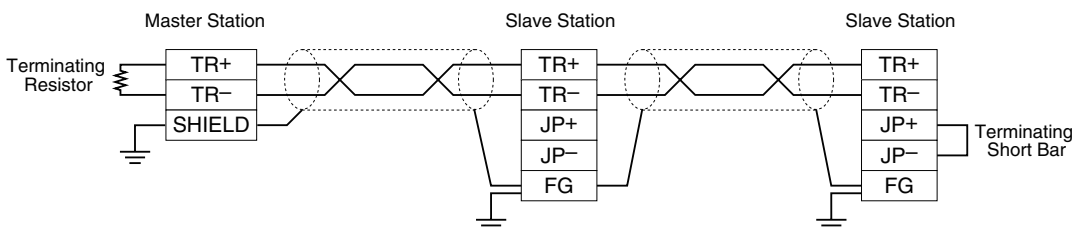

Note: Be sure to use the terminator(s) located at both ends of the modules.

DATA CONVERSION

■ 0 – 100% DATA CONVERSION

Analog input data is converted into digital representations of 0 – 100% proportional to each scaled range. The converted % values are multiplied by 100 and expressed in 16 bits.

Ovrange input is possible from -15 to +115% of the nominal range. When the signal exceeds the limit, the data is fixed at -15% or +115% respectively. Negative value is represented in 2's complements.

• Input Range 0 – 5 V DC

Input Value	Input %	Converted Data, Decimal	Converted Data, Hex
≤ -0.75 V	-15%	-1500	FA24
0 V	0%	0	0
5 V	100%	10000	2710
≥ 5.75 V	115%	11500	2CEC

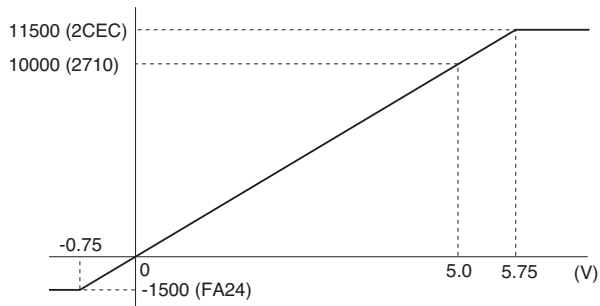

Analog output is converted in the reverse order of the input data. The output range 0 – 5 V DC is expressed as 10000 at 5.0 V (100%) and 0 at 0 V (0%).

■ ENGINEERING UNIT CONVERSION

Engineering unit value °C or K is multiplied by 10 and expressed in 16 bits. °F data is represented in engineering unit value, without multiplication. Negative value is represented in 2's complements.

• Input TYPE K Thermocouple

Input Value	Converted Data, Decimal	Converted Data, Hex
≤ -272°C	-2720	F560
-150°C	-1500	FA24
1370°C	13700	3584
≥ 1472°C	14720	3980

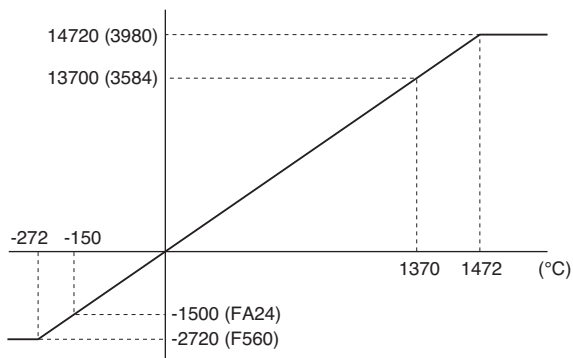

I/O DATA DESCRIPTIONS

■ DISCRETE I/O

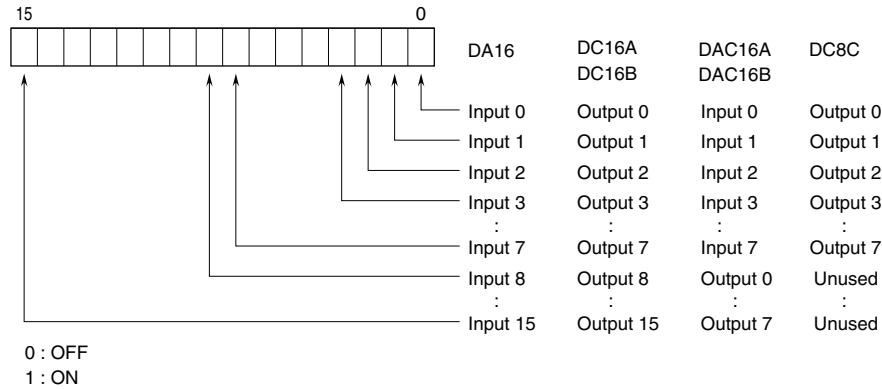

■ ANALOG I/O

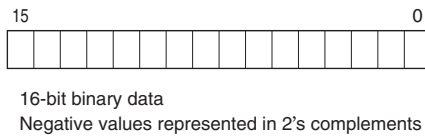

DIMENSIONS unit: mm (inch)

■ DISCRETE I/O MODULE, ANALOG INPUT MODULE

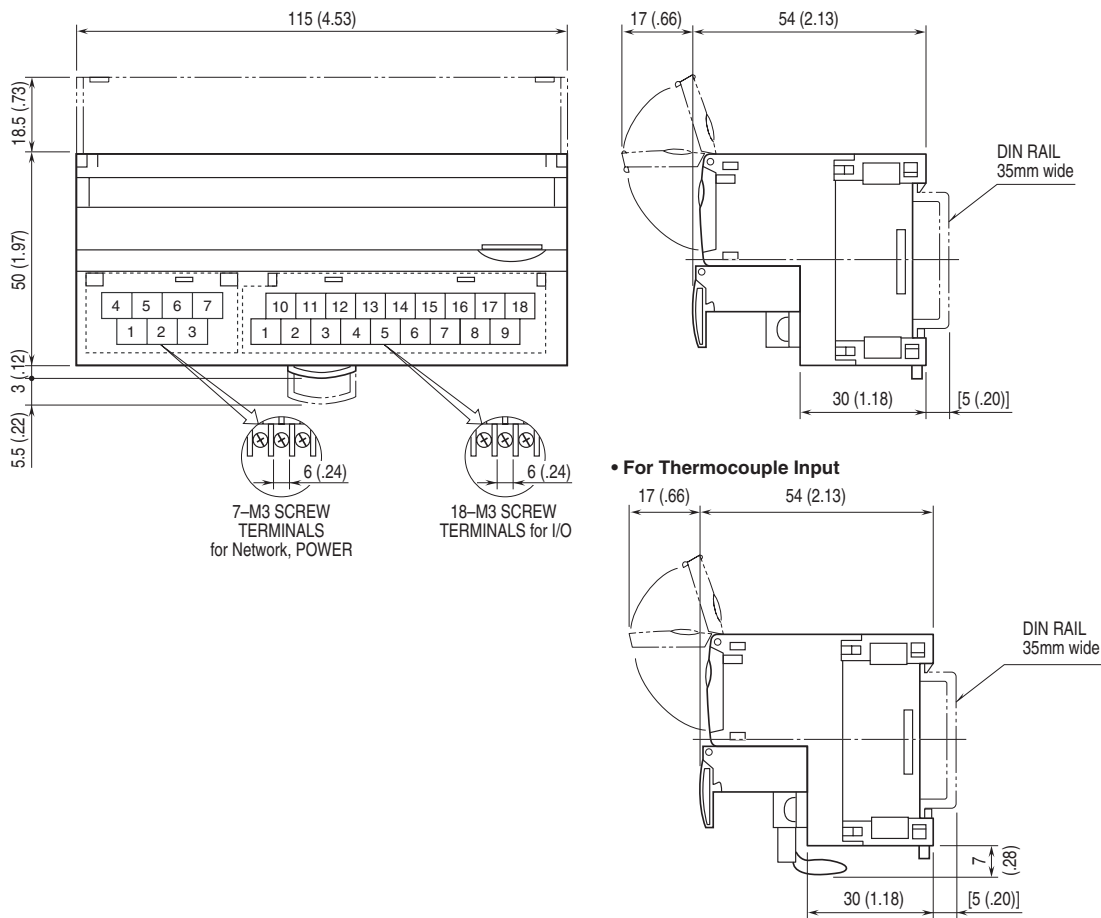

■ ANALOG OUTPUT

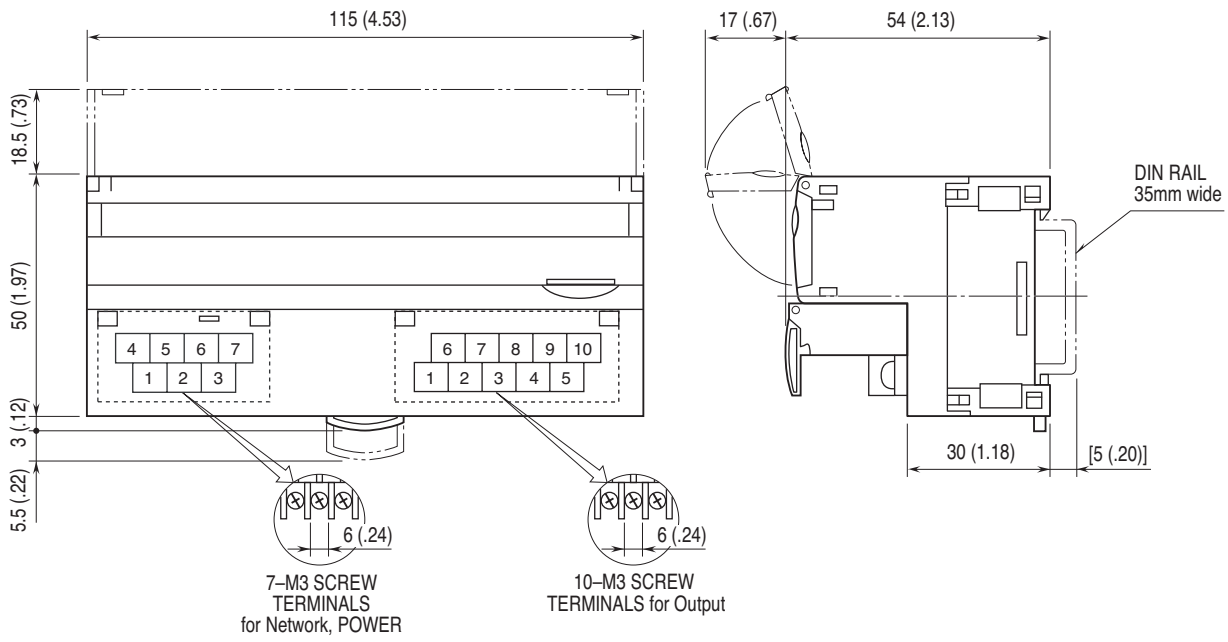

DISCRETE INPUT MODULE, 16 points

MODEL:R7FN-DA16

SPECIFICATIONS

Common: Positive or negative common (NPN/PNP) per 16 points
Number of I/O: Input, 16 points
Maximum inputs applicable at once: No limit (at 24 V DC)
Input status indicator LED: Turns ON with contact ON
Isolation: Input to FLEX NETWORK to power input to FG
Data allocation: 1
Rated input voltage: 24 V DC $\pm 10\%$; ripple 5 %p-p max.
ON voltage / current: ≥ 15 V DC (input - COM) / ≥ 3.5 mA
OFF voltage / current: ≤ 5 V DC (input - COM) / ≤ 1 mA
Input current: ≤ 5.5 mA per point at 24 V DC
Input resistance: Approx. 4.4 k Ω
ON delay: ≤ 2.0 msec.
OFF delay: ≤ 2.0 msec.

TERMINAL ASSIGNMENTS

10	11	12	13	14	15	16	17	18
COM	X1	X3	X5	X7	X9	XB	XD	XF
1	2	3	4	5	6	7	8	9
COM	X0	X2	X4	X6	X8	XA	XC	XE

NO.	ID	FUNCTION	NO.	ID	FUNCTION
1	COM	Common	10	COM	Common
2	X0	Input 0	11	X1	Input 1
3	X2	Input 2	12	X3	Input 3
4	X4	Input 4	13	X5	Input 5
5	X6	Input 6	14	X7	Input 7
6	X8	Input 8	15	X9	Input 9
7	XA	Input 10	16	XB	Input 11
8	XC	Input 12	17	XD	Input 13
9	XE	Input 14	18	XF	Input 15

CIRCUIT DIAGRAM

Note: In order to improve EMC performance, bond the FG terminal to ground.

Caution: FG terminal is NOT a protective conductor terminal.

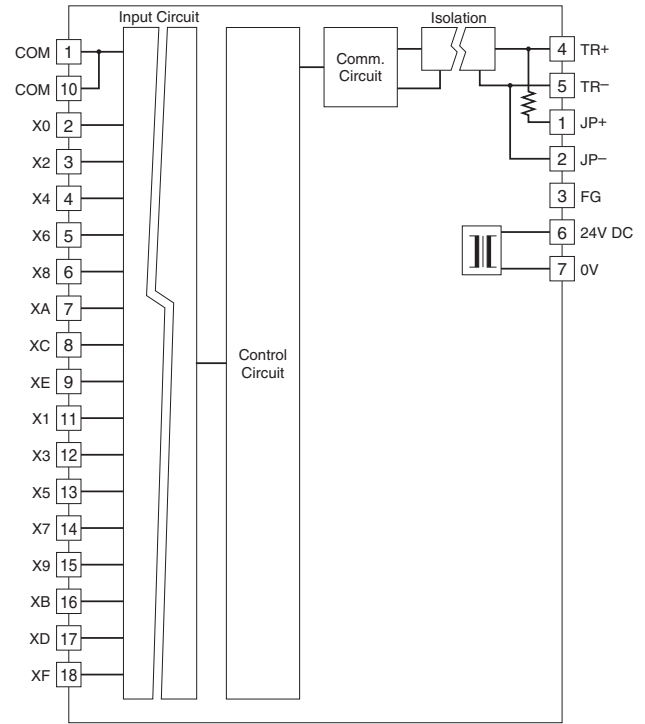

Input Circuit

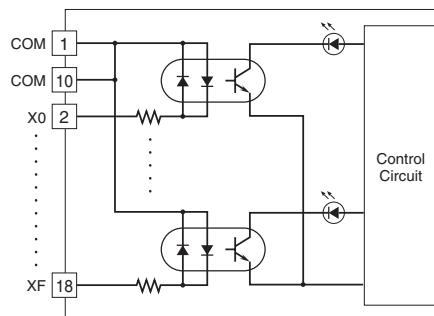

Input Connection Example

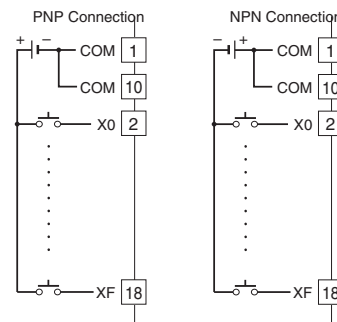

NPN TRANSISTOR OUTPUT MODULE, 16 points

MODEL:R7FN-DC16A

SPECIFICATIONS

- Common:** Negative common (NPN) per 16 points
- Number of I/O:** Output, 16 points
- Maximum outputs applicable at once:** No limit (at 24 V DC)
- Output status indicator LED:** Turns ON with contact ON
- Isolation:** Output to FLEX NETWORK to power input to FG
- Data allocation:** 1
- Rated load voltage:** 24 V DC $\pm 10\%$
- Rated output current:** 0.25 A per point, 2.0 A per common
- Residual voltage:** ≤ 1.2 V
- Leakage current:** ≤ 0.1 mA
- ON delay:** ≤ 0.5 msec.
- OFF delay:** ≤ 1.5 msec.

OPERATING MODE SETTING

(*) Factory setting

Caution ! - SW1-1 through 1-6 are unused. Be sure to turn off unused ones.

• Output at the loss of communication (SW1-7)

SW1-7	OUTPUT AT THE LOSS OF COMMUNICATION
OFF	Hold the output (*) (maintains the last data received normally)
ON	Reset the output (turned off)

TERMINAL ASSIGNMENTS

10	11	12	13	14	15	16	17	18
+24 V	Y1	Y3	Y5	Y7	Y9	YB	YD	YF
1	2	3	4	5	6	7	8	9
0 V	Y0	Y2	Y4	Y6	Y8	YA	YC	YE

NO.	ID	FUNCTION	NO.	ID	FUNCTION
1	0 V	0 V (common)	10	+24 V	24 V DC
2	Y0	Output 0	11	Y1	Output 1
3	Y2	Output 2	12	Y3	Output 3
4	Y4	Output 4	13	Y5	Output 5
5	Y6	Output 6	14	Y7	Output 7
6	Y8	Output 8	15	Y9	Output 9
7	YA	Output 10	16	YB	Output 11
8	YC	Output 12	17	YD	Output 13
9	YE	Output 14	18	YF	Output 15

CIRCUIT DIAGRAM

Note: In order to improve EMC performance, bond the FG terminal to ground.

Caution: FG terminal is NOT a protective conductor terminal.

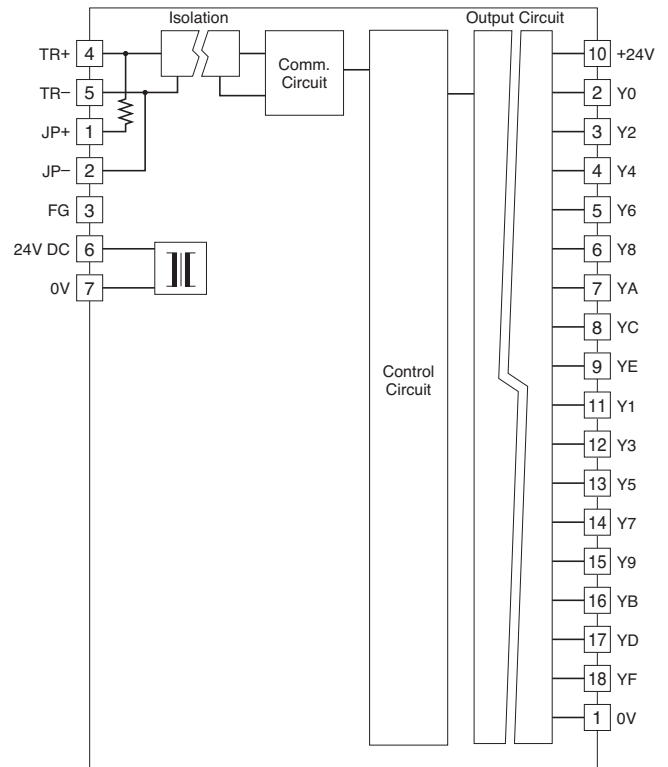

■ Output Circuit

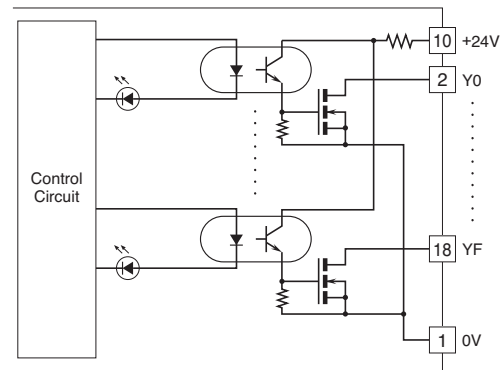

■ Output Connection Example

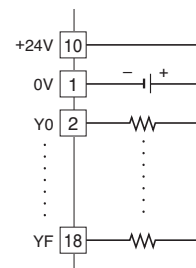

PNP TRANSISTOR OUTPUT MODULE, 16 points

MODEL:R7FN-DC16B

SPECIFICATIONS

- Common:** Positive common (PNP) per 16 points
- Number of I/O:** Output, 16 points
- Maximum outputs applicable at once:** No limit (at 24 V DC)
- Output status indicator LED:** Turns ON with contact ON
- Isolation:** Output to FLEX NETWORK to power input to FG
- Data allocation:** 1
- Rated load voltage:** 24 V DC $\pm 10\%$
- Rated output current:** 0.25 A per point, 2.0 A per common
- Residual voltage:** ≤ 1.2 V
- Leakage current:** ≤ 0.1 mA
- ON delay:** ≤ 0.5 msec.
- OFF delay:** ≤ 1.5 msec.

OPERATING MODE SETTING

(*) Factory setting

Caution ! - SW1-1 through 1-6 are unused. Be sure to turn off unused ones.

• Output at the loss of communication (SW1-7)

SW1-7	OUTPUT AT THE LOSS OF COMMUNICATION
OFF	Hold the output (*) (maintains the last data received normally)
ON	Reset the output (turned off)

TERMINAL ASSIGNMENTS

10	11	12	13	14	15	16	17	18
+24 V	Y1	Y3	Y5	Y7	Y9	YB	YD	YF
1	2	3	4	5	6	7	8	9
0 V	Y0	Y2	Y4	Y6	Y8	YA	YC	YE

NO.	ID	FUNCTION	NO.	ID	FUNCTION
1	0 V	0 V	10	+24 V	24 V DC (common)
2	Y0	Output 0	11	Y1	Output 1
3	Y2	Output 2	12	Y3	Output 3
4	Y4	Output 4	13	Y5	Output 5
5	Y6	Output 6	14	Y7	Output 7
6	Y8	Output 8	15	Y9	Output 9
7	YA	Output 10	16	YB	Output 11
8	YC	Output 12	17	YD	Output 13
9	YE	Output 14	18	YF	Output 15

CIRCUIT DIAGRAM

Note: In order to improve EMC performance, bond the FG terminal to ground.

Caution: FG terminal is NOT a protective conductor terminal.

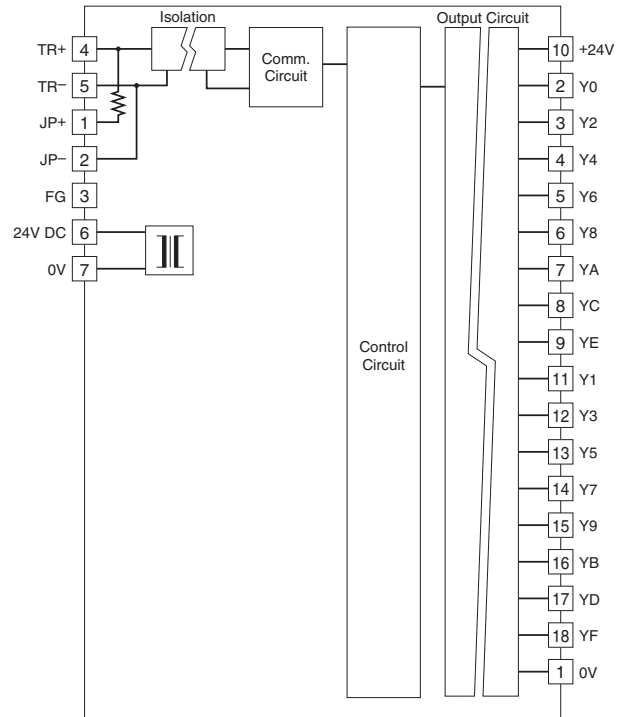

■ Output Circuit

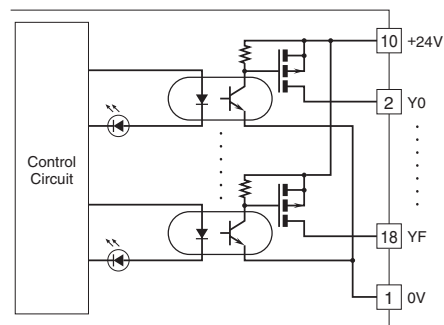

■ Output Connection Example

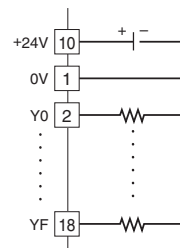

DISCRETE INPUT & NPN TRANSISTOR OUTPUT MODULE, 8 points each

MODEL:R7FN-DAC16A

TERMINAL ASSIGNMENTS

10 +24V	11 X1	12 X3	13 X5	14 X7	15 Y1	16 Y3	17 Y5	18 Y7
1 COM	2 X0	3 X2	4 X4	5 X6	6 Y0	7 Y2	8 Y4	9 Y6

SPECIFICATIONS

COMMON SPECIFICATIONS

Common: Negative common (NPN) per 16 points
Number of I/O: Input, 8 points; Output, 8 points
Maximum I/O applicable at once: No limit (at 24 V DC)
I/O status indicator LED: Turns ON with contact ON
Isolation: Input or output to FLEX NETWORK to power input to FG
Data allocation: 1

INPUT

Rated input voltage: 24 V DC $\pm 10\%$; ripple 5 %p-p max.
ON voltage/current: ≥ 15 V DC (input-COM) / ≥ 3.5 mA
OFF voltage/current: ≤ 5 V DC (input-COM) / ≤ 1 mA
Input current: ≤ 5.5 mA per point at 24 V DC
Input resistance: Approx. 4.4 k Ω
ON delay: ≤ 2.0 msec.
OFF delay: ≤ 2.0 msec.

OUTPUT

Rated load voltage: 24 V DC $\pm 10\%$
Rated output current: 0.25 A per point, 2.0 A per common
Residual voltage: ≤ 1.2 V
Leakage current: ≤ 0.1 mA
ON delay: ≤ 0.5 msec.
OFF delay: ≤ 1.5 msec.

NO.	ID	FUNCTION	NO.	ID	FUNCTION
1	COM	Common	10	+24V	24V DC
2	X0	Input 0	11	X1	Input 1
3	X2	Input 2	12	X3	Input 3
4	X4	Input 4	13	X5	Input 5
5	X6	Input 6	14	X7	Input 7
6	Y0	Output 0	15	Y1	Output 1
7	Y2	Output 2	16	Y3	Output 3
8	Y4	Output 4	17	Y5	Output 5
9	Y6	Output 6	18	Y7	Output 7

OPERATING MODE SETTING

(*) Factory setting

Caution ! - SW1-1 through 1-6 are unused. Be sure to turn off unused ones.

Output at the loss of communication (SW1-7)

SW1-7	OUTPUT AT THE LOSS OF COMMUNICATION
OFF	Hold the output (*) (maintains the last data received normally)
ON	Reset the output (turned off)



CIRCUIT DIAGRAM

Note: In order to improve EMC performance, bond the FG terminal to ground.

Caution: FG terminal is NOT a protective conductor terminal.

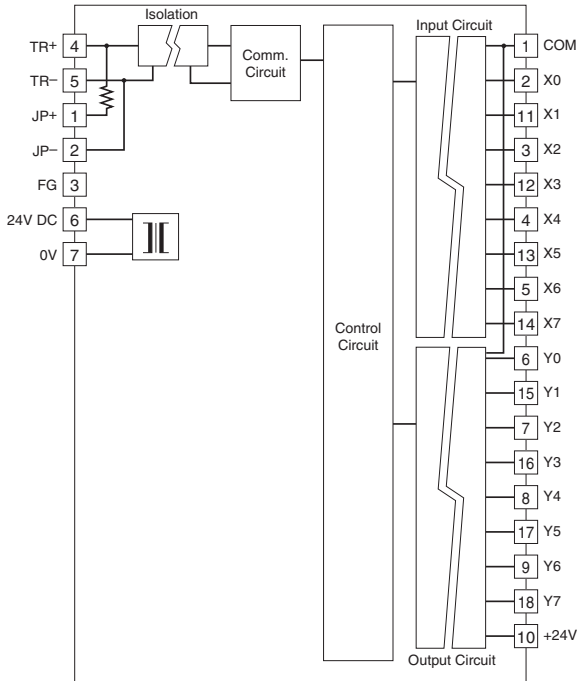

■ Input Circuit

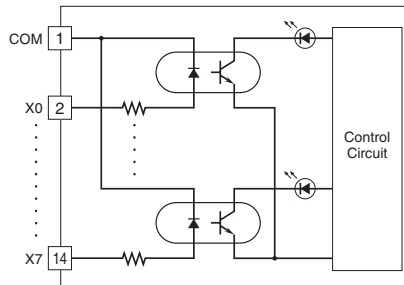

■ Output Circuit

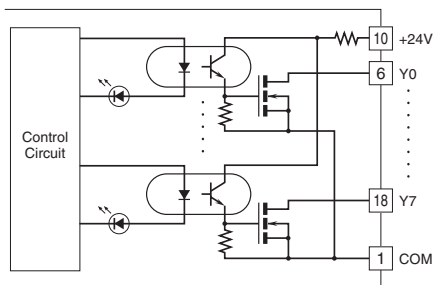

■ I/O Connection Example

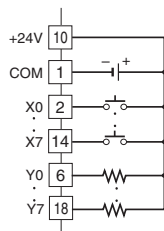

DISCRETE INPUT & PNP TRANSISTOR OUTPUT MODULE, 8 points each

MODEL:R7FN-DAC16B

TERMINAL ASSIGNMENTS

10 +24V	11 X1	12 X3	13 X5	14 X7	15 Y1	16 Y3	17 Y5	18 Y7
1 COM	2 X0	3 X2	4 X4	5 X6	6 Y0	7 Y2	8 Y4	9 Y6

SPECIFICATIONS

COMMON SPECIFICATIONS

Common: Positive common (PNP) per 16 points
Number of I/O: Input, 8 points; Output, 8 points
Maximum I/O applicable at once: No limit (at 24 V DC)
I/O status indicator LED: Turns ON with contact ON
Isolation: Input or output to FLEX NETWORK to power input to FG
Data allocation: 1

INPUT

Rated input voltage: 24 V DC $\pm 10\%$; ripple 5 %p-p max.
ON voltage/current: ≥ 15 V DC (input-COM) / ≥ 3.5 mA
OFF voltage/current: ≤ 5 V DC (input-COM) / ≤ 1 mA
Input current: ≤ 5.5 mA per point at 24 V DC
Input resistance: Approx. 4.4 k Ω
ON delay: ≤ 2.0 msec.
OFF delay: ≤ 2.0 msec.

OUTPUT

Rated load voltage: 24 V DC $\pm 10\%$
Rated output current: 0.25 A per point, 2.0 A per common
Residual voltage: ≤ 1.2 V
Leakage current: ≤ 0.1 mA
ON delay: ≤ 0.5 msec.
OFF delay: ≤ 1.5 msec.

NO.	ID	FUNCTION	NO.	ID	FUNCTION
1	COM	Common	10	+24V	24V DC
2	X0	Input 0	11	X1	Input 1
3	X2	Input 2	12	X3	Input 3
4	X4	Input 4	13	X5	Input 5
5	X6	Input 6	14	X7	Input 7
6	Y0	Output 0	15	Y1	Output 1
7	Y2	Output 2	16	Y3	Output 3
8	Y4	Output 4	17	Y5	Output 5
9	Y6	Output 6	18	Y7	Output 7

OPERATING MODE SETTING

(*) Factory setting

Caution ! - SW1-1 through 1-6 are unused. Be sure to turn off unused ones.

Output at the loss of communication (SW1-7)

SW1-7	OUTPUT AT THE LOSS OF COMMUNICATION
OFF	Hold the output (*) (maintains the last data received normally)
ON	Reset the output (turned off)



CIRCUIT DIAGRAM

Note: In order to improve EMC performance, bond the FG terminal to ground.

Caution: FG terminal is NOT a protective conductor terminal.

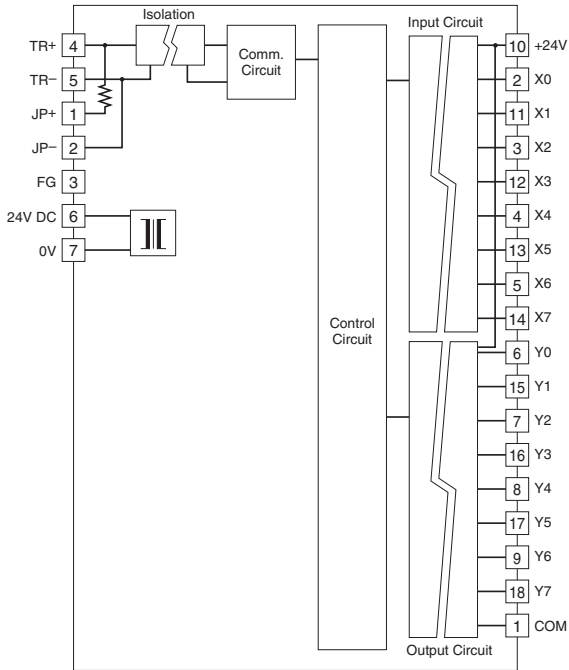

■ Input Circuit

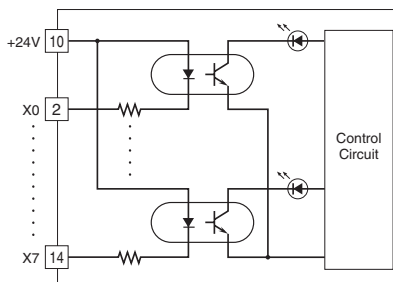

■ Output Circuit

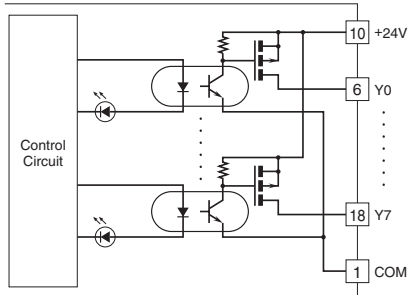

■ I/O Connection Example

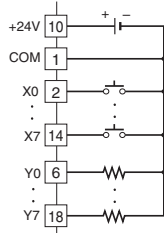

RELAY CONTACT OUTPUT MODULE, 8 points

MODEL:R7FN-DC8C

SPECIFICATIONS

- Common:** 1 common per 4 points (4 terminals)
- Maximum current load:** 1.0 A per point
- Common current:** Max. 4 A (4 terminals)
- Number of I/O:** Relay contact output, 8 points
- Maximum outputs applicable at once:** No limit (at 24 V DC)
- Output status indicator LED:** Turns ON with contact ON
- Isolation:** Output to FLEX NETWORK to power input to FG
- Data allocation:** 1
- Relay driving power:** 24 V DC $\pm 10\%$, ≥ 60 mA
- Rated load:** 250 V AC* @ 1 A ($\cos \phi = 1$)
30 V DC @ 1 A (resistive load)
- Electrical life** 10^5 cycles (rate 30/min.)
- *Limited to the max. voltage 125 V AC or to the use for Measurement Category I in order to conform with EC Directive.
- Maximum switching voltage:** 250 V AC or 30 V DC
- Maximum switching power:** 250 VA or 30 W
- Minimum load:** 24 V DC @5 mA
- Mechanical life:** 2×10^7 cycles (rate 300/min.)
- When driving an inductive load, external contact protection and noise quenching are recommended.
- ON delay:** ≤ 10 msec.
- OFF delay:** ≤ 10 msec.

OPERATING MODE SETTING

- (*) Factory setting
 - Caution ! - SW1-1 through 1-6 are unused. Be sure to turn off unused ones.
 - **Output at the loss of communication (SW1-7)**
- | SW1-7 | OUTPUT AT THE LOSS OF COMMUNICATION |
|-------|--|
| OFF | Hold the output (*)
(maintains the last data received normally) |
| ON | Reset the output (turned off) |

TERMINAL ASSIGNMENTS

10	11	12	13	14	15	16	17	18
+24V	Y0	Y1	Y2	Y3	Y4	Y5	Y6	Y7
1	2	3	4	5	6	7	8	9
0V	COM0	COM0	COM0	COM0	COM1	COM1	COM1	COM1

NO.	ID	FUNCTION	NO.	ID	FUNCTION
1	0 V	0 V	10	+24 V	24 V DC
2	COM0	Common 0	11	Y0	Output 0
3	COM0	Common 0	12	Y1	Output 1
4	COM0	Common 0	13	Y2	Output 2
5	COM0	Common 0	14	Y3	Output 3
6	COM1	Common 1	15	Y4	Output 4
7	COM1	Common 1	16	Y5	Output 5
8	COM1	Common 1	17	Y6	Output 6
9	COM1	Common 1	18	Y7	Output 7

CIRCUIT DIAGRAM

Note: In order to improve EMC performance, bond the FG terminal to ground.
Caution: FG terminal is NOT a protective conductor terminal.

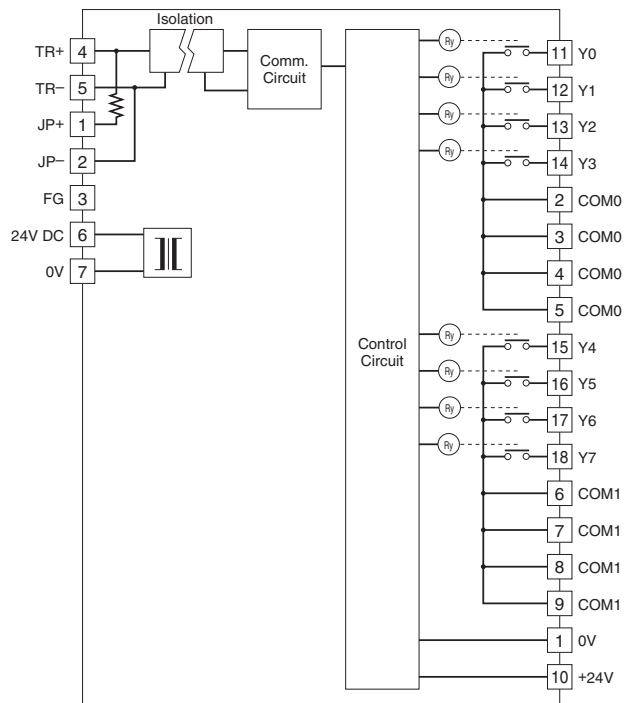

Output Connection Example

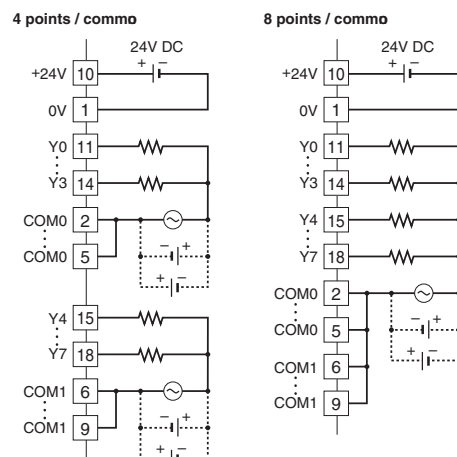

DC VOLTAGE/CURRENT INPUT MODULE, 4 points

MODEL: R7FN-SV4

SPECIFICATIONS

Isolation: Input 0 to input 1 to input 2 to input 3 to FLEX NETWORK to power input to FG

Data allocation: 4

Converted data range: 0 - 10000 of the input range

• **Input range**

Wide span voltage: -10 - +10 V DC, -5 - +5 V DC, 0 - 10 V DC, 0 - 5 V DC, 1 - 5 V DC

Narrow span voltage: -1 - +1 V DC, 0 - 1 V DC, -0.5 - +0.5 V DC

Current range: -20 - +20 mA DC, 0 - 20 mA DC, 4 - 20 mA DC

• **Input resistance**

Wide span voltage: $\geq 1 \text{ M}\Omega$

Narrow span voltage: $\geq 100 \text{ k}\Omega$

Current range: 70Ω

Conversion rate / conversion accuracy:

10 msec./ $\pm 0.8 \%$, 20 msec./ $\pm 0.4 \%$, 40 msec./ $\pm 0.2 \%$,

80 msec./ $\pm 0.1 \%$

Response time: Conversion rate $\times 2 + 50$ msec. (0 - 90 %)

Temperature coefficient: $\pm 0.015 \%/^{\circ}\text{C}$ ($\pm 0.008 \%/^{\circ}\text{F}$)

OPERATING MODE SETTING

(*) Factory setting

Caution ! - SW1-1, SW1-2 and SW1-7 are unused. Be sure to turn off unused ones.

• **Input range (SW1-3, 1-4, 1-5, 1-6)**

SW1-3	SW1-4	SW1-5	SW1-6	INPUT RANGE
OFF	OFF	OFF	OFF	-10 - +10V DC (*)
ON	OFF	OFF	OFF	-5 - +5V DC
OFF	ON	OFF	OFF	-1 - +1V DC
ON	ON	OFF	OFF	0 - 10V DC
OFF	OFF	ON	OFF	0 - 5V DC
ON	OFF	ON	OFF	1 - 5V DC
OFF	ON	ON	OFF	0 - 1V DC
ON	ON	ON	OFF	-0.5 - +0.5V DC
ON	OFF	OFF	ON	-20 - +20mA DC
OFF	ON	OFF	ON	4 - 20mA DC
ON	ON	OFF	ON	0 - 20mA DC
ON	ON	ON	ON	PC Configurator setting

TERMINAL ASSIGNMENTS

10	11	12	13	14	15	16	17	18
VL0	I0	VL1	I1	NC	VL2	I2	VL3	I3
1	2	3	4	5	6	7	8	9
VH0	COM0	VH1	COM1	NC	VH2	COM2	VH3	COM3

NO.	ID	FUNCTION	NO.	ID	FUNCTION
1	VH0	Wide span volt. 0	10	VL0	Narrow span volt. 0
2	COM0	Common 0	11	I0	Current range 0
3	VH1	Wide span volt. 1	12	VL1	Narrow span volt. 1
4	COM1	Common 1	13	I1	Current range 1
5	NC	No connection	14	NC	No connection
6	VH2	Wide span volt. 2	15	VL2	Narrow span volt. 2
7	COM2	Common 2	16	I2	Current range 2
8	VH3	Wide span volt. 3	17	VL3	Narrow span volt. 3
9	COM3	Common 3	18	I3	Current range 3

CIRCUIT DIAGRAM

Note: In order to improve EMC performance, bond the FG terminal to ground.

Caution: FG terminal is NOT a protective conductor terminal.

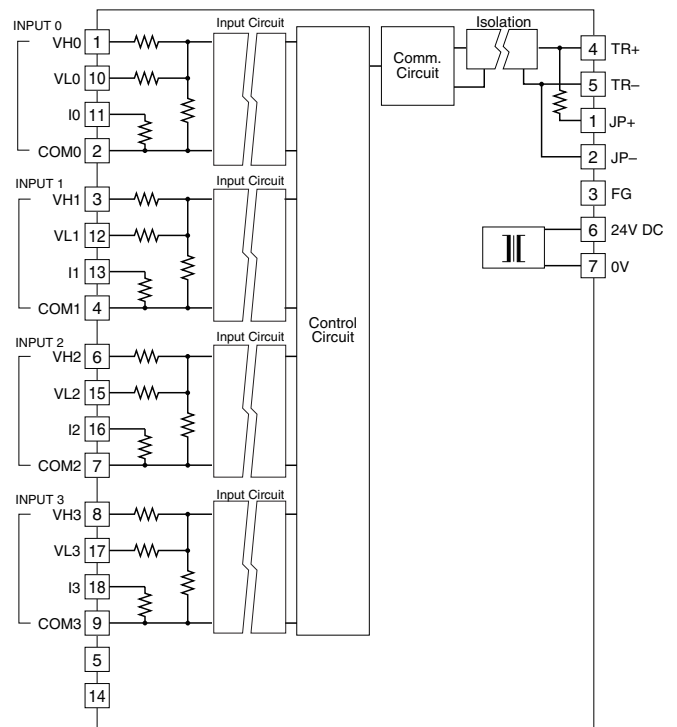

Input Connection Examples

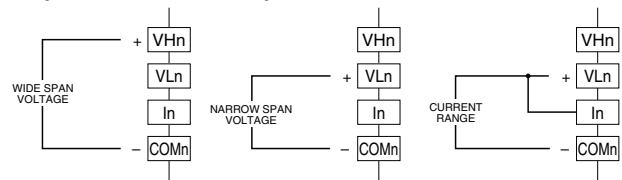

Be sure to close across VLn and In terminals for a current input.



DC VOLTAGE/CURRENT INPUT MODULE, 4 points

(high speed, non-isolated)

MODEL: R7FN-SVF4

SPECIFICATIONS

Isolation: Input to FLEX NETWORK to power input to FG

Data allocation: 4

Converted data range: 0 - 10000 of the input range

• **Input range**

Wide span voltage: -10 - +10 V DC, -5 - +5 V DC,
0 - 10 V DC, 0 - 5 V DC, 1 - 5 V DC

Narrow span voltage: -1 - +1 V DC, 0 - 1 V DC,
-0.5 - +0.5 V DC

Current range: -20 - +20 mA DC, 0 - 20 mA DC,
4 - 20 mA DC

• **Input resistance**

Wide span voltage: > 1 MΩ

Narrow span voltage: > 100 kΩ

Current range: 50 Ω

Moving average: No averaging, 2, 4, 8 samples
(Selectable with PC Configurator Software)

Conversion rate/conversion accuracy: 2 msec./±0.1 %

Response time: Conversion rate × 2 + scan time (0 - 90 %)

Scan time depends on the Final Satellite (FS) value of Center IC (master) configuration and transfer rate (T_{BPS}).

It is calculated with the following formula.

Scan time = 354 × FS × T_{BPS} (seconds)

E.g) When "Final satellite value = 63, transfer rate = 12 Mbps, scan time is = 354 × 63 × 1/12 M = 1.859 msec.

Temperature coefficient: ±0.015 %/°C (±0.008 %/°F)

OPERATING MODE SETTING

(*) Factory setting

Caution ! - SW1-1, SW1-2 and SW1-7 are unused. Be sure to turn off unused ones.

• **Input range (SW1-3, 1-4, 1-5, 1-6)**

SW1-3	SW1-4	SW1-5	SW1-6	INPUT RANGE
OFF	OFF	OFF	OFF	-10 - +10V DC (*)
ON	OFF	OFF	OFF	-5 - +5V DC
OFF	ON	OFF	OFF	-1 - +1V DC
ON	ON	OFF	OFF	0 - 10V DC
OFF	OFF	ON	OFF	0 - 5V DC
ON	OFF	ON	OFF	1 - 5V DC
OFF	ON	ON	OFF	0 - 1V DC
ON	ON	ON	OFF	-0.5 - +0.5V DC
ON	OFF	OFF	ON	-20 - +20mA DC
OFF	ON	OFF	ON	4 - 20mA DC
ON	ON	OFF	ON	0 - 20mA DC
ON	ON	ON	ON	PC Configurator setting

TERMINAL ASSIGNMENTS

10	11	12	13	14	15	16	17	18
VL0	I0	VL1	I1	NC	VL2	I2	VL3	I3
1	2	3	4	5	6	7	8	9
VH0	COM0	VH1	COM1	NC	VH2	COM2	VH3	COM3

NO.	ID	FUNCTION	NO.	ID	FUNCTION
1	VH0	Wide span volt. 0	10	VL0	Narrow span volt. 0
2	COM0	Common 0	11	I0	Current range 0
3	VH1	Wide span volt. 1	12	VL1	Narrow span volt. 1
4	COM1	Common 1	13	I1	Current range 1
5	NC	No connection	14	NC	No connection
6	VH2	Wide span volt. 2	15	VL2	Narrow span volt. 2
7	COM2	Common 2	16	I2	Current range 2
8	VH3	Wide span volt. 3	17	VL3	Narrow span volt. 3
9	COM3	Common 3	18	I3	Current range 3

CIRCUIT DIAGRAM

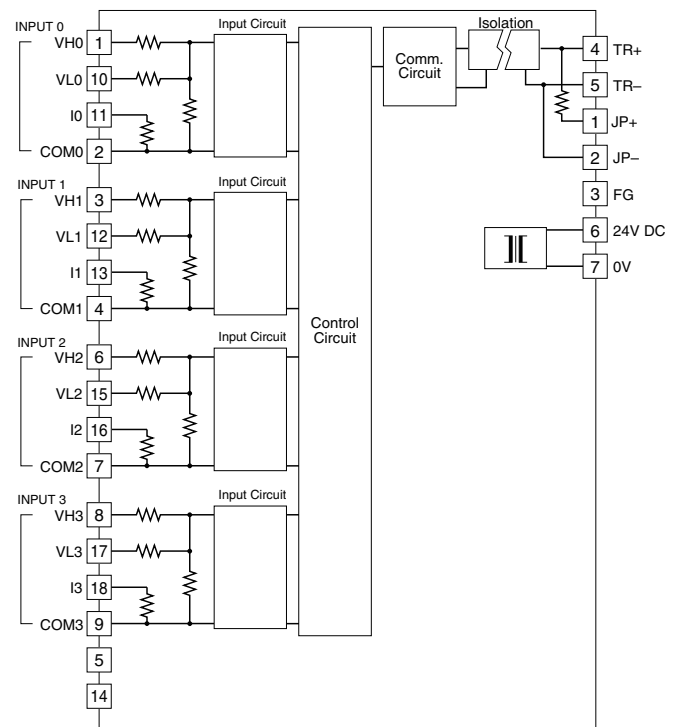

Input Connection Examples

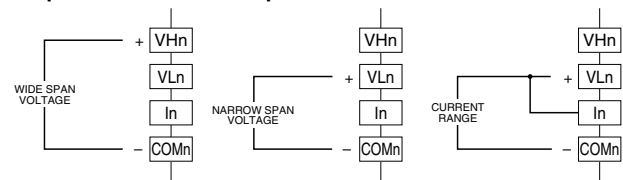

Be sure to close across VLn and In terminals for a current input.



THERMOCOUPLE INPUT MODULE, 4 points

MODEL: R7FN-TS4

SPECIFICATIONS

Isolation: Input 0 to input 1 to input 2 to input 3 to FLEX NETWORK to power input to FG

Data allocation: 4

Converted data range: Engineering unit value (°C, K) × 10 (integer); No multiplication for °F

Thermocouple: K, E, J, T, B, R, S, C, N, U, L, P, PR

Cold junction compensation: CJC sensor attached to the input terminals

Input resistance: ≥ 30 kΩ

Burnout: Upscale or downscale selectable with the DIP SW

Burnout sensing: ≤ 0.1 μA

Linearization: Standard

Conversion accuracy: ±1°C (±1.8°F);

±2.0°C (±3.6°F) for B, R, S, C, PR

Conversion rate: 250 msec. or 500 msec.

Response time: Conversion rate × 2 + 50 msec. (0 - 90 %)

Temperature coefficient: ±0.015 %/°C (±0.008 %/°F)

CJC error: ±1.0°C at 25°C ±10°C

(±1.8°F at 77°F ±18°F)

±1.5°C (±2.7°F) for R, S, PR

OPERATING MODE SETTING

(*) Factory setting

Caution ! - SW1-1 and SW1-7 are unused. Be sure to turn off unused ones.

• Thermocouple type (SW1-3, 1-4, 1-5, 1-6)

SW1-3	SW1-4	SW1-5	SW1-6	THERMOCOUPLE TYPE
OFF	OFF	OFF	OFF	K (CA) (*)
ON	OFF	OFF	OFF	E (CRC)
OFF	ON	OFF	OFF	J (IC)
ON	ON	OFF	OFF	T (CC)
OFF	OFF	ON	OFF	B (RH)
ON	OFF	ON	OFF	R
OFF	ON	ON	OFF	S
ON	ON	ON	OFF	C (WRe 5-26)
OFF	OFF	OFF	ON	N
ON	OFF	OFF	ON	U
OFF	ON	OFF	ON	L
ON	ON	OFF	ON	P (Platinel II)
OFF	OFF	ON	ON	(PR)
ON	ON	ON	ON	PC Configurator setting

• Burnout (SW1-2)

SW1-2	BURNOUT
OFF	Upscale (*)
ON	Downscale

TERMINAL ASSIGNMENTS

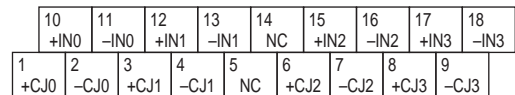

NO.	ID	FUNCTION	NO.	ID	FUNCTION
1	+CJ0	CJC 0	10	+IN0	T/C + 0
2	-CJ0	CJC 0	11	-IN0	T/C - 0
3	+CJ1	CJC 1	12	+IN1	T/C + 1
4	-CJ1	CJC 1	13	-IN1	T/C - 1
5	NC	No connection	14	NC	No connection
6	+CJ2	CJC 2	15	+IN2	T/C + 2
7	-CJ2	CJC 2	16	-IN2	T/C - 2
8	+CJ3	CJC 3	17	+IN3	T/C + 3
9	-CJ3	CJC 3	18	-IN3	T/C - 3

T/C	BURNOUT INDICATION (°C)		CONFORMANCE RANGE (°C)
	Downscale	Upscale	
K (CA)	-272	+1472	-150 to +1370
E (CRC)	-272	+1120	-170 to +1000
J (IC)	-260	+1300	-180 to +1200
T (CC)	-272	+ 500	-170 to + 400
B (RH)	24	1920	400 to 1760
R	-100	+1860	200 to 1760
S	-100	+1860	0 to 1760
C (WRe 5-26)	-52	+2416	0 to 2315
N	-272	+1400	-130 to +1300
U	-252	+ 700	-200 to +600
L	-252	+1000	-200 to +900
P (Platinel II)	-52	+1496	0 to 1395
(PR)	-52	+1860	0 to 1760

T/C	BURNOUT INDICATION (°F)		CONFORMANCE RANGE (°F)
	Downscale	Upscale	
K (CA)	-458	+2682	-238 to +2498
E (CRC)	-458	+2048	-274 to +1832
J (IC)	-436	+2372	-292 to +2192
T (CC)	-458	+932	-274 to +752
B (RH)	75	3488	752 to 3200
R	-148	+3380	392 to 3200
S	-148	+3380	32 to 3200
C (WRe 5-26)	-62	+4381	32 to 4199
N	-458	+2552	-202 to +2372
U	-422	+1292	-328 to +1112
L	-422	+1832	-328 to +1652
P (Platinel II)	-62	+2725	32 to 2543
(PR)	-62	+3380	32 to 3200



CIRCUIT DIAGRAM

Note: In order to improve EMC performance, bond the FG terminal to ground.

Caution: FG terminal is NOT a protective conductor terminal.

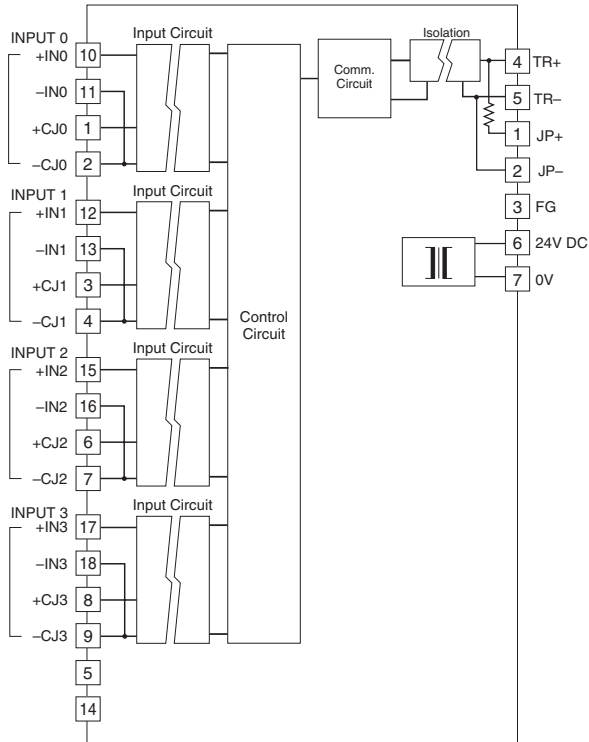

■ Input Connection Example

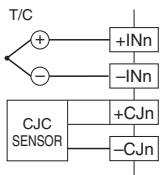

RTD INPUT MODULE, 4 points

MODEL: R7FN-RS4

SPECIFICATIONS

Isolation: Input 0 to input 1 to input 2 to input 3 to FLEX NETWORK to power input to FG

Data allocation: 4

Converted data range: Engineering unit value (°C, K) × 10 (integer); No multiplication for °F

RTD: Pt 100 (JIS '97, IEC), Pt 100 (JIS '89), JPt 100 (JIS '89), Pt 50 Ω (JIS '81), Ni 100, Cu 10, Cu 50

Sensing current: ≤ 1 mA

Input resistance: ≥ 1 MΩ

Maximum leadwire resistance: 100 Ω per wire

Burnout: Upscale or downscale selectable with the DIP SW

Burnout indication: Maximum value (upscale burnout) or minimum value (downscale burnout) of the usable range

Linearization: Standard

Conversion accuracy: ±1°C (±1.8°F);

±3°C (±5.4°F) for Cu 10

Conversion rate: 250 msec. or 500 msec.

Response time: Conversion rate × 2 + 50 msec. (0 - 90 %)

Temperature coefficient: ±0.015 %/°C (±0.008 %/°F)

RTD	USABLE RANGE (°C)		CONFORMANCE RANGE (°C)
	Downscale	Upscale	
Pt 100 (JIS '97/IEC)	-240	+900	-200 to +850
Pt 100 (JIS '89)	-240	+900	-200 to +660
JPt 100 (JIS '89)	-236	+560	-200 to +510
Pt 50 Ω (JIS '81)	-236	+700	-200 to +649
Ni 100	-100	+252	-80 to +250
Cu 10 (25°C)	-212	+312	-50 to +250
Cu 50	-100	+200	-50 to +150

RTD	USABLE RANGE (°F)		CONFORMANCE RANGE (°C)
	Downscale	Upscale	
Pt 100 (JIS '97/IEC)	-400	+1652	-328 to +1562
Pt 100 (JIS '89)	-400	+1652	-328 to +1220
JPt 100 (JIS '89)	-393	+1040	-328 to +950
Pt 50 Ω (JIS '81)	-393	+1292	-328 to +1200
Ni 100	-148	+486	-112 to +482
Cu 10 (25°C)	-350	+594	-58 to +482
Cu 50	-148	+392	-58 to +302

Max. (upscale) or min. (downscale) value of the usable range when a burnout is detected. Overrange input (out of the usable range) is also handled as burnout.

OPERATING MODE SETTING

(*) Factory setting

Caution ! - SW1-1 and SW1-7 are unused. Be sure to turn off unused ones.

• RTD type (SW1-3, 1-4, 1-5, 1-6)

SW1-3	SW1-4	SW1-5	SW1-6	RTD TYPE
OFF	OFF	OFF	OFF	Pt 100 (JIS '97, IEC) (*)
ON	OFF	OFF	OFF	Pt 100 (JIS '89)
OFF	ON	OFF	OFF	JPt 100 (JIS '89)
ON	ON	OFF	OFF	Pt 50 (JIS '81)
OFF	OFF	ON	OFF	Ni 100
ON	OFF	ON	OFF	Cu 10 (25°C)
OFF	OFF	OFF	ON	Cu 50
ON	ON	ON	ON	PC Configurator setting

• Burnout (SW1-2)

SW1-2	BURNOUT
OFF	Upscale (*)
ON	Downscale

TERMINAL ASSIGNMENTS

10	11	12	13	14	15	16	17	18
INA0	INb0	INA1	INb1	NC	INA2	INb2	INA3	INb3
1	2	3	4	5	6	7	8	9
NC	INB0	NC	INB1	NC	NC	INB2	NC	INB3

NO.	ID	FUNCTION	NO.	ID	FUNCTION
1	NC	No connection	10	INA0	RTD 0-A
2	INB0	RTD 0-B	11	INb0	RTD 0-b
3	NC	No connection	12	INA1	RTD 1-A
4	INB1	RTD 1-B	13	INb1	RTD 1-b
5	NC	No connection	14	NC	No connection
6	NC	No connection	15	INA2	RTD 2-A
7	INB2	RTD 2-B	16	INb2	RTD 2-b
8	NC	No connection	17	INA3	RTD 3-A
9	INB3	RTD 3-B	18	INb3	RTD 3-b



CIRCUIT DIAGRAM

Note: In order to improve EMC performance, bond the FG terminal to ground.

Caution: FG terminal is NOT a protective conductor terminal.

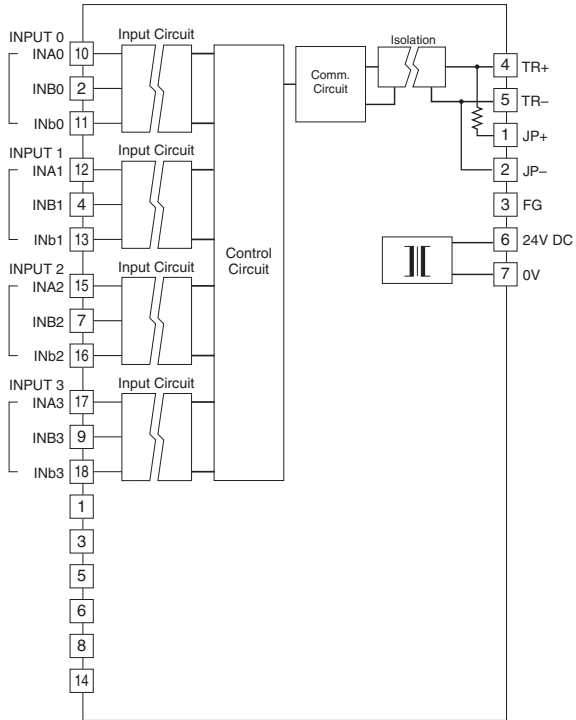

■ Input Connection Example

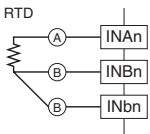

DC VOLTAGE OUTPUT MODULE, 2 points

MODEL: R7FN-YV2

SPECIFICATIONS

Isolation: Output 0 to output 1 to power input to FLEX NETWORK to FG

Data allocation: 2

Converted data range: 0 - 10000 of the output range

Output range

Wide span voltage: -10 - +10 V DC, -5 - +5 V DC, 0 - 10 V DC, 0 - 5 V DC, 1 - 5 V DC

Narrow span voltage: -1 - +1 V DC, 0 - 1 V DC, -0.5 - +0.5 V DC

Operational range: -15 - +115 % of the output range (except -10 - +10 V DC);

approx. -11.5 - +11.5 V DC (-10 - +10 V DC)

Load resistance: $\geq 100 \text{ k}\Omega$

Conversion accuracy: $\pm 0.1 \%$

Response time: 250 msec. (0 - 90 %)

Temperature coefficient: $\pm 0.015 \%/^{\circ}\text{C}$ ($\pm 0.008 \%/^{\circ}\text{F}$)

OPERATING MODE SETTING

(*) Factory setting

Caution ! - SW1-1 and SW1-2 are unused. Be sure to turn off unused ones.

• **Output range (SW1-3, 1-4, 1-5, 1-6)**

SW1-3	SW1-4	SW1-5	SW1-6	OUTPUT RANGE
OFF	OFF	OFF	OFF	-10 - +10V DC (*)
ON	OFF	OFF	OFF	-5 - +5V DC
OFF	ON	OFF	OFF	-1 - +1V DC
ON	ON	OFF	OFF	0 - 10V DC
OFF	OFF	ON	OFF	0 - 5V DC
ON	OFF	ON	OFF	1 - 5V DC
OFF	ON	ON	OFF	0 - 1V DC
ON	ON	ON	OFF	-0.5 - +0.5V DC
ON	ON	ON	ON	PC Configurator setting

• **Output at the loss of communication (SW1-7)**

SW1-7	OUTPUT AT THE LOSS OF COMMUNICATION
OFF	Hold the output (*) (maintains the last data received normally)
ON	Reset the output (to -15% or approx. -11.5 V DC)

TERMINAL ASSIGNMENTS

6	7	8	9	10
NC	VH0	VL0	VH1	VL1
1	2	3	4	5
NC	COM0	COM0	COM1	COM1

NO.	ID	FUNCTION	NO.	ID	FUNCTION
1	NC	No connection	6	NC	No connection
2	COM0	Common 0	7	VH0	Wide span volt. 0
3	COM0	Common 0	8	VL0	Narrow span volt. 0
4	COM1	Common 1	9	VH1	Wide span volt. 1
5	COM1	Common 1	10	VL1	Narrow span volt. 1

CIRCUIT DIAGRAM

Note: In order to improve EMC performance, bond the FG terminal to ground.

Caution: FG terminal is NOT a protective conductor terminal.

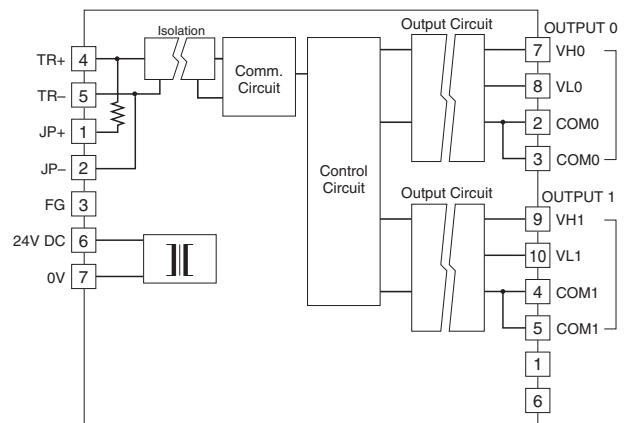

Output Connection Examples

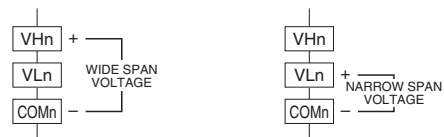

DC CURRENT OUTPUT MODULE, 2 points

MODEL: R7FN-YS2

SPECIFICATIONS

Isolation: Output 0 to output 1 to power input to FLEX NETWORK to FG

Data allocation: 2

Converted data range: 0 - 10000 of the output range

Output range: 4 - 20 mA DC

Load resistance: $\leq 600\Omega$

Conversion accuracy: $\pm 0.1\%$

Response time: 250 msec. (0 - 90 %)

Temperature coefficient: $\pm 0.015\%/^{\circ}\text{C}$ ($\pm 0.008\%/^{\circ}\text{F}$)

OPERATING MODE SETTING

(*) Factory setting

Caution ! - SW1-1 through 1-6 are unused. Be sure to turn off unused ones.

• **Output at the loss of communication (SW1-7)**

SW1-7	OUTPUT AT THE LOSS OF COMMUNICATION
OFF	Hold the output (*) (maintains the last data received normally)
ON	Reset the output (to -15%)

TERMINAL ASSIGNMENTS

6	7	8	9	10
NC	I0	NC	I1	NC
1	2	3	4	5
NC	COM0	NC	COM1	NC

NO.	ID	FUNCTION	NO.	ID	FUNCTION
1	NC	No connection	6	NC	No connection
2	COM0	Common 0	7	I0	Current 0
3	NC	No connection	8	NC	No connection
4	COM1	Common 1	9	I1	Current 1
5	NC	No connection	10	NC	No connection

CIRCUIT DIAGRAM

Note: In order to improve EMC performance, bond the FG terminal to ground.

Caution: FG terminal is NOT a protective conductor terminal.

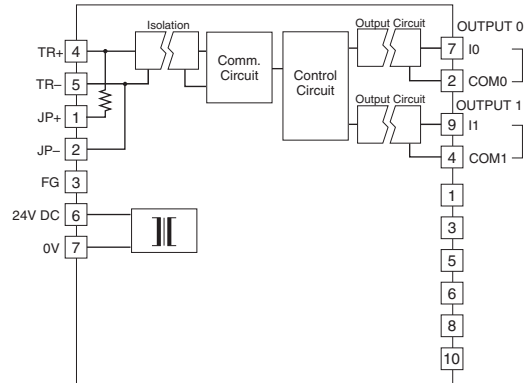



Specifications are subject to change without notice.

