

Remote I/O R7F4D Series

HIGH-SPEED LINK SYSTEM I/O MODULE

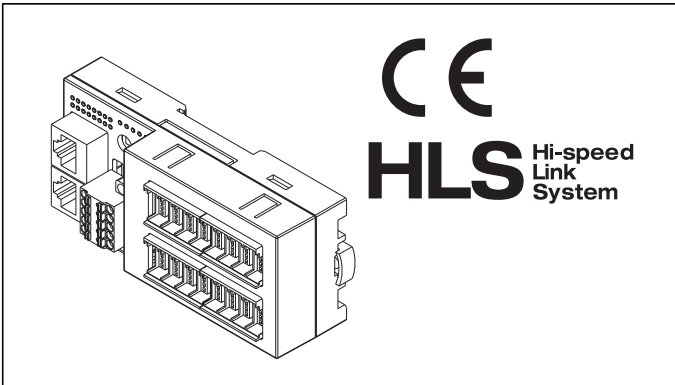

MODEL: R7F4DH-[1]-[2]-R[3]

ORDERING INFORMATION

- Code number: R7F4DH-[1]-[2]-R[3]
- Specify a code from below for each [1] through [3]
(e.g. R7F4DH-1-DA16A-R/H)

[1] TERMINAL BLOCK

- 1: Tension clamp terminal block for power supply
RJ-45 Modular jack for communication
e-CON connector for I/O
- 2: Tension clamp terminal block for power supply
RJ-45 Modular jack for communication
MIL connector 1 for I/O
- 3: Tension clamp terminal block for power supply
RJ-45 Modular jack for communication
MIL connector 2 for I/O
- 4: Tension clamp terminal block for power supply
RJ-45 Modular jack for communication
Tension clamp terminal block for I/O

[2] I/O TYPE

- DA16A:** NPN discrete input, 16 points
DA16B: PNP discrete input, 16 points
DC16A: NPN transistor output, 16 points
DC16B: PNP transistor output, 16 points
DAC16A: PNP discrete input &
 NPN transistor output, 8 points each
DAC16B: NPN discrete input &
 PNP transistor output, 8 points each
DAC16C: NPN discrete input &
 NPN transistor output, 8 points each
DAC16D: PNP discrete input &
 PNP transistor output, 8 points each

POWER INPUT

DC Power
 R: 24 V DC

[3] OPTIONS

Communication Mode
 blank: Full-duplex
 /H: Half-duplex

FUNCTIONS & FEATURES

The R7F4DH interfaces discrete I/O signals with a PLC via HLS.
 (HLS is the abbreviation for "High-speed Link System" of Step Technica Co., Ltd.)

GENERAL SPECIFICATIONS

- **Common Specifications**
- Power input:** 24 V DC $\pm 10\%$; ripple 10 %p-p max.
Sensor excitation: 24 V DC $\pm 10\%$; ripple 5 %p-p max., ≤ 2 A (including discrete I/O load charge)
Insulation resistance: ≥ 100 M Ω with 500 V DC
Dielectric strength: 1500 V AC @1 minute (between isolated circuits)
Operating temperature: -10 to +55°C (14 to 131°F)
Operating humidity: 30 to 90 %RH (non-condensing)
Atmosphere: No corrosive gas or heavy dust
Mounting: DIN rail or wall
Status indicator: Power LED on with power supplied
Discrete I/O status indicator: Red LED on in contact.
Communication Failure Detection: At communication error, the output status until normal data is received (Hold or OFF) can be set with the DIP SW. (only for output devices; factory setting: Hold)
- **Current Consumption & Weight**

R7F4DH-x-DA16A: Approx. 25 mA/100 g (0.22 lbs)
 R7F4DH-x-DA16B: Approx. 25 mA/100 g (0.22 lbs)
 R7F4DH-x-DC16A: Approx. 50 mA/100 g (0.22 lbs)
 R7F4DH-x-DC16B: Approx. 50 mA/100 g (0.22 lbs)
 R7F4DH-x-DAC16A: Approx. 35 mA/100 g (0.22 lbs)
 R7F4DH-x-DAC16B: Approx. 35 mA/100 g (0.22 lbs)
 R7F4DH-x-DAC16C: Approx. 35 mA/100 g (0.22 lbs)
 R7F4DH-x-DAC16D: Approx. 35 mA/100 g (0.22 lbs)
 (Discrete I/O load charge is not included in the above-mentioned current consumption.)

HLS COMMUNICATION

Communication mode: Full-duplex or half-duplex
Network cable
 Full-duplex communication:
 ZHY262PS and ZHT262PS (Shinko Seisen Industry Co., Ltd.)



Half-duplex communication:

ZHY221PS (Shinko Seisen Industry Co., Ltd.)

Dual-shield cable:

ZHY262PBA (Shinko Seisen Industry Co., Ltd.)

Transmission distance:

12 Mbps: 100 meters (328 ft)

6 Mbps: 200 meters (656 ft)

3 Mbps: 300 meters (984 ft)

(Baud rate configurable with DIP SW; factory setting: 12 Mbps)

Terminating resistor: Built-in (Selected with the DIP SW; factory setting: disabled)

Status indicator: Run LED on in normal communication

Station address: Set with rotary switch

(Refer to the instruction manual for details.)

STANDARDS & APPROVALS

CE conformity:

EMC Directive (2004/108/EC)

EMI EN 61000-6-4: 2007

EMS EN 61000-6-2: 2005

EXTERNAL VIEW

■ TERMINAL CODE 1 (e-CON)

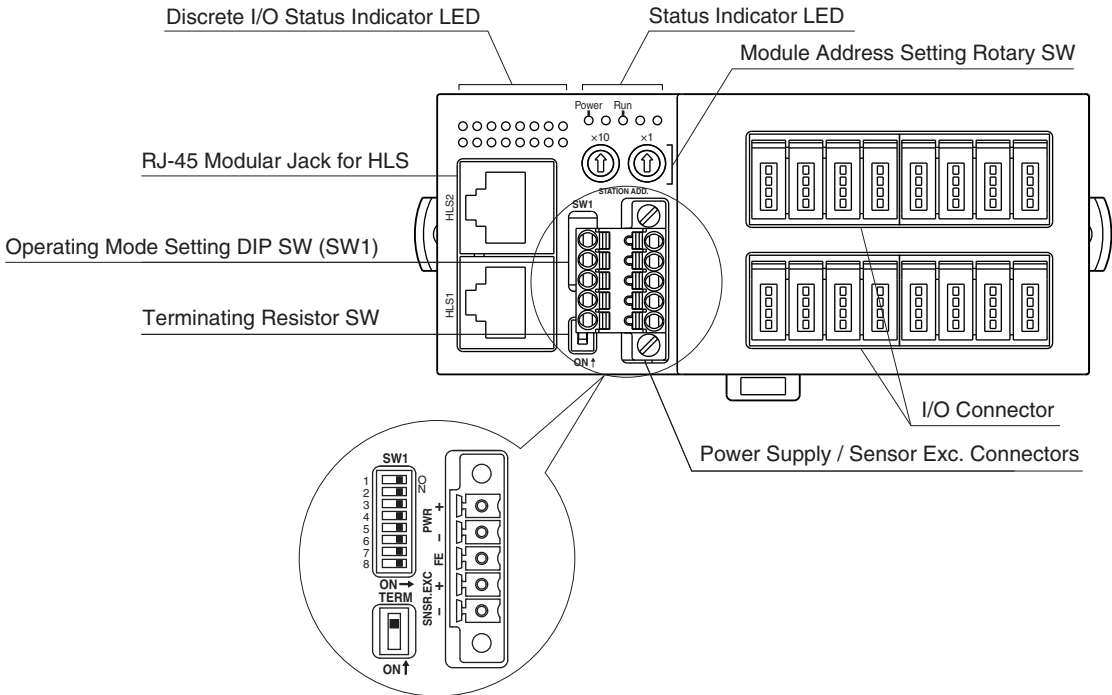

■ **TERMINAL CODE 2, 3 (MIL)**

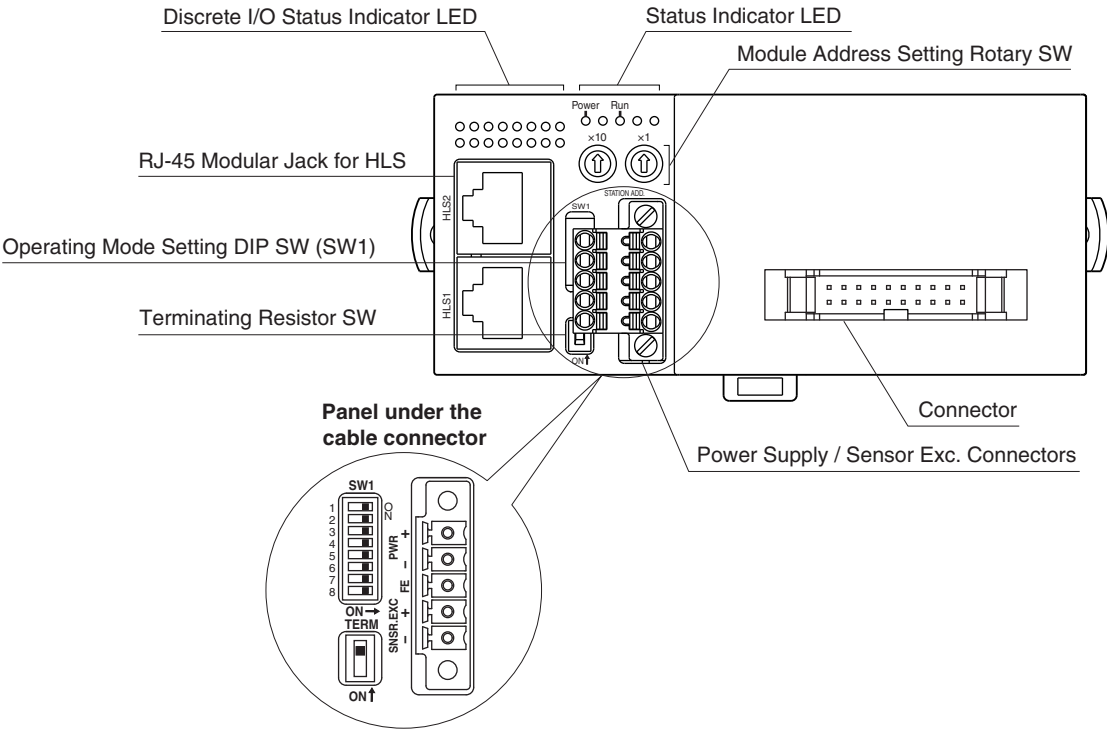

■ **TERMINAL CODE 4 (Tension Clamp)**

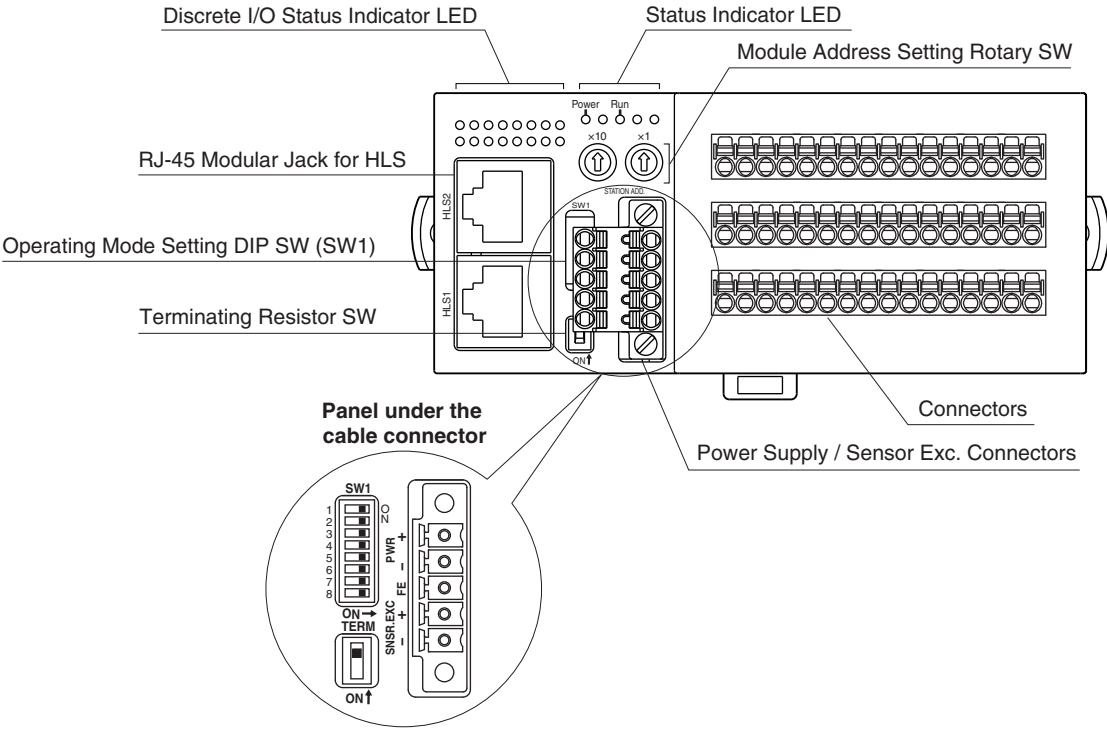

CONNECTION DIAGRAMS

■ I/O connection (Refer to each model terminal assignment)

• e-CON connector

Recommended cable connector: 37104-()-000FL (3M Company)

(The cable connector is not included in the package.)

Specify wire size instead of (); refer to the specifications of the product.)

• MIL connector

Recommended cable connector: XG4M-2030 (Omron)

(The cable connector is not included in the package.)

• Tension clamp terminal block

Cable connector: FMC1,5/16-ST-3,5 (Phoenix Contact)

(The cable connector is included in the package.)

Applicable wire size: 0.2 – 1.5 mm²; stripped length 10 mm

Recommended solderless terminal

- AI0,25–12BU 0.25 mm² (Phoenix Contact)
- AI0,34–12TQ 0.34 mm² (Phoenix Contact)
- AI0,5–10WH 0.5 mm² (Phoenix Contact)
- AI0,75–10GY 0.75 mm² (Phoenix Contact)
- A1–10 1.0 mm² (Phoenix Contact)
- A1,5–10 1.5 mm² (Phoenix Contact)

■ POWER SUPPLY

Cable connector: TFMC1,5 / 5–STF–3,5

(Phoenix Contact) (included in the package)

Applicable wire size: 0.2 – 1.5 mm²; stripped length 10 mm

Recommended solderless terminal

- AI0,25–12BU 0.25 mm² (Phoenix Contact)
- AI0,34–12TQ 0.34 mm² (Phoenix Contact)
- AI0,5–10WH 0.5 mm² (Phoenix Contact)
- AI0,75–10GY 0.75 mm² (Phoenix Contact)
- A1–10 1.0 mm² (Phoenix Contact)
- A1,5–10 1.5 mm² (Phoenix Contact)

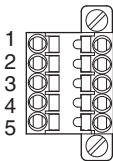

- | | |
|--------------|-------------------|
| 1. PWR+ | Power Supply |
| 2. PWR– | Power Supply |
| 3. FE | Functional earth |
| 4. SNSR.EXC+ | Sensor excitation |
| 5. SNSR.EXC– | Sensor excitation |



■ NETWORK

Recommended cable connector: TM21P-88P (Hirose Electric)
(not included in the package)

• Full-duplex communication

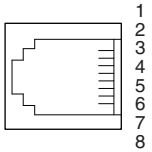

- 1. NC Unused
- 2. NC Unused
- 3. TXD+ Network (slave, transmission +)
- 4. TXD- Network (slave, transmission -)
- 5. RXD+ Network (master, transmission +)
- 6. RXD- Network (master, transmission -)
- 7. NC Unused
- 8. SLD Shield

• Half-duplex communication

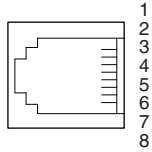

- 1. NC Unused
- 2. NC Unused
- 3. TR+ Network (+)
- 4. TR- Network (-)
- 5. NC Unused
- 6. NC Unused
- 7. NC Unused
- 8. SLD Shield

■ MASTER CONNECTION

• Full-duplex communication

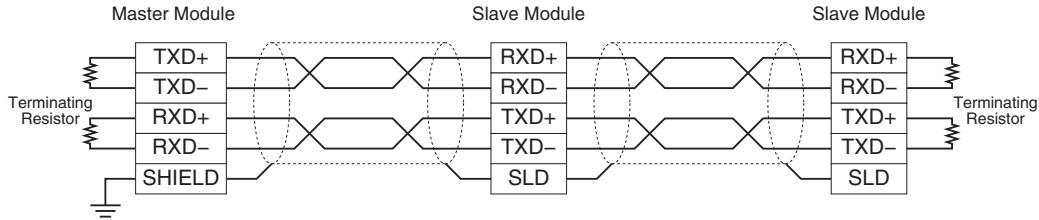

• Half-duplex communication

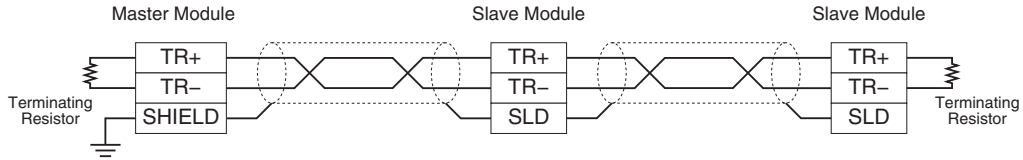

Note: Be sure to turn ON the switch of the terminating resistor located at both ends of the modules.



I/O DATA DESCRIPTIONS

■ DISCRETE INPUT

• Di

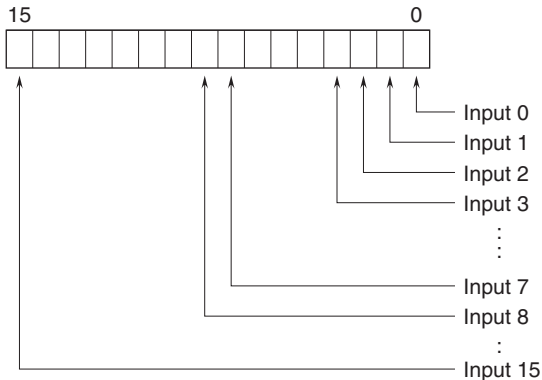

0: OFF
1: ON

• Do

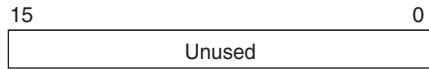

■ DISCRETE OUTPUT

• Di

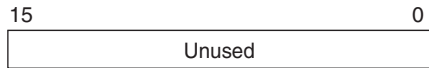

• Do

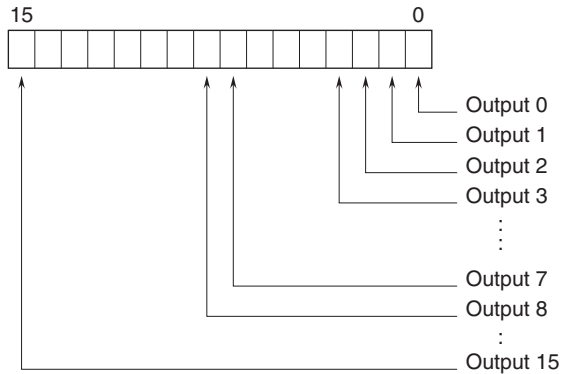

■ DISCRETE I/O

• Di

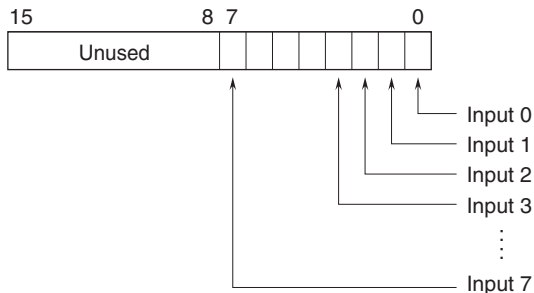

• Do

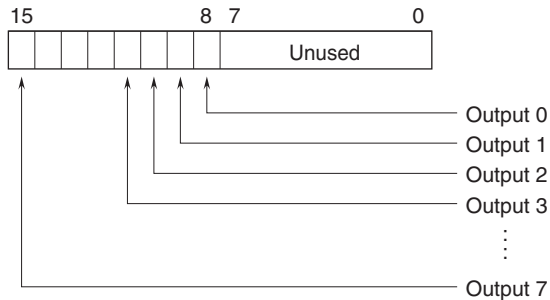

DIMENSIONS unit: mm (inch)

■ **TERMINAL CODE 1 (e-CON)**

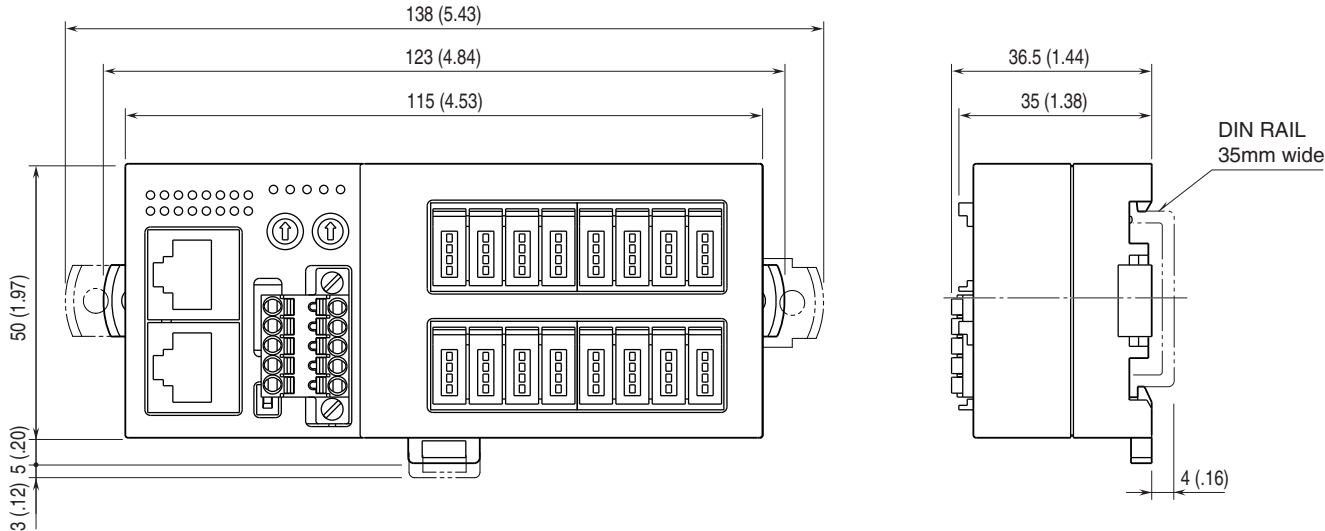

■ **TERMINAL CODE 2, 3 (MIL)**

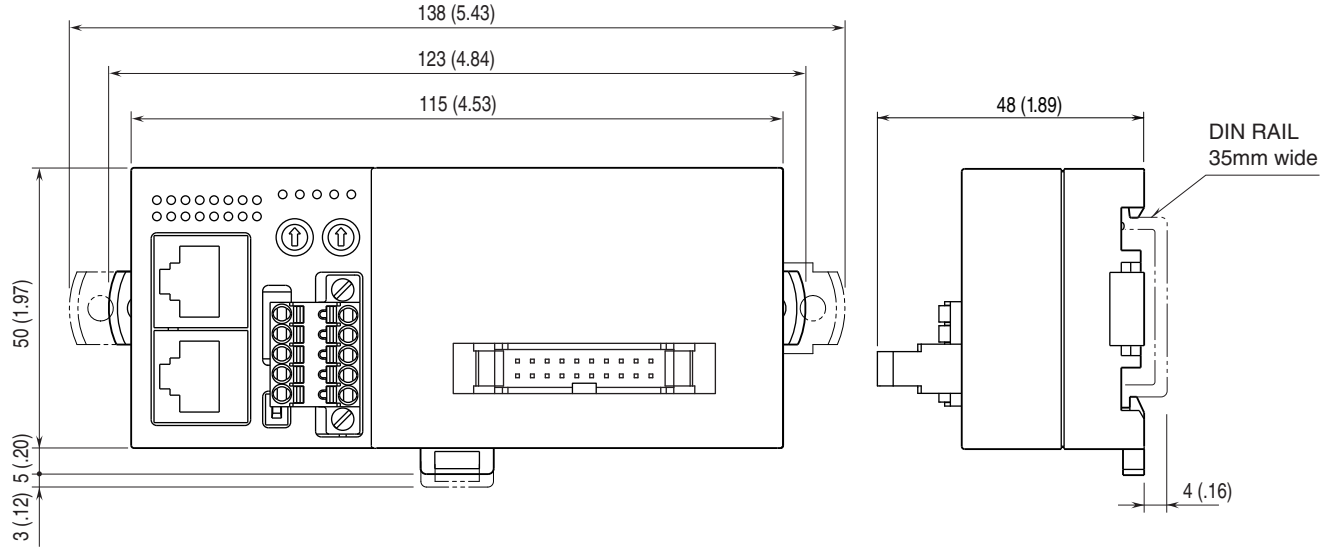

■ TERMINAL CODE 4 (Tension Clamp)

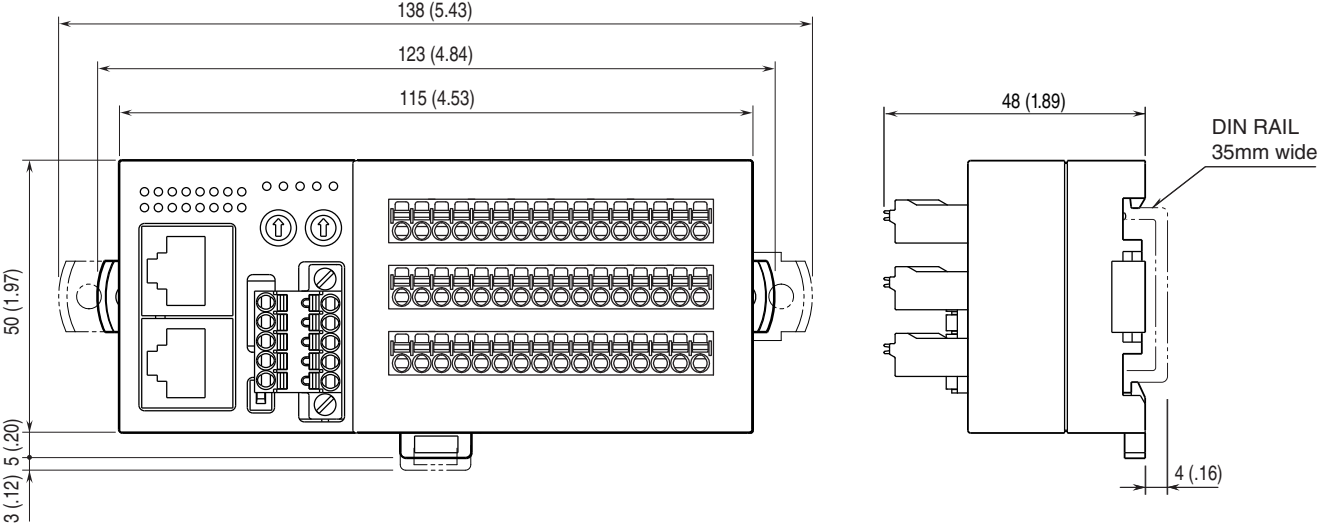

MOUNTING REQUIREMENTS unit: mm (inch)

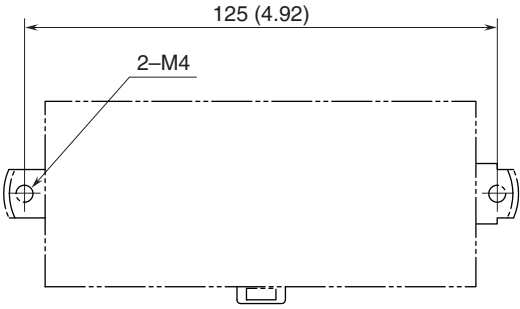

NPN DISCRETE INPUT MODULE, 16 points

(e-CON connector)

MODEL: R7F4DH-1-DA16A

SPECIFICATIONS

Common: Positive common (NPN) per 16 points

Number of I/O: Input, 16 points

Maximum inputs applicable at once: No limit (at 24 V DC)

I/O status indicator: LED turns on with closed contact.

Isolation: Input or sensor excitation to HLS to power input to FE

Data allocation: 1

Rated input voltage: 24 V DC $\pm 10\%$; ripple 5 %p-p max.

ON voltage / current: ≥ 15 V DC (input - +24V) / ≥ 3.5 mA

OFF voltage / current: ≤ 5 V DC (input - +24V) / ≤ 1 mA

Input current: ≤ 5.5 mA per point at 24 V DC

Input resistance: Approx. 4.4 k Ω

ON delay: ≤ 0.5 msec.

OFF delay: ≤ 0.5 msec.

TERMINAL ASSIGNMENTS

Input Connection

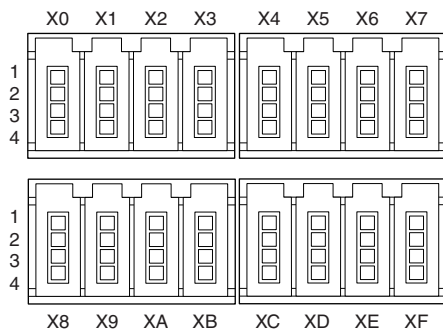

No.	ID	FUNCTION	No.	ID	FUNCTION
X0	1	+24V	X8	1	+24V
	2	NC		2	NC
	3	GND		3	GND
	4	X0		4	X8
X1	1	+24V	X9	1	+24V
	2	NC		2	NC
	3	GND		3	GND
	4	X1		4	X9
X2	1	+24V	XA	1	+24V
	2	NC		2	NC
	3	GND		3	GND
	4	X2		4	XA
X3	1	+24V	XB	1	+24V
	2	NC		2	NC
	3	GND		3	GND
	4	X3		4	XB
X4	1	+24V	XC	1	+24V
	2	NC		2	NC
	3	GND		3	GND
	4	X4		4	XC
X5	1	+24V	XD	1	+24V
	2	NC		2	NC
	3	GND		3	GND
	4	X5		4	XD
X6	1	+24V	XE	1	+24V
	2	NC		2	NC
	3	GND		3	GND
	4	X6		4	XE
X7	1	+24V	XF	1	+24V
	2	NC		2	NC
	3	GND		3	GND
	4	X7		4	XF

SCHEMATIC CIRCUITRY

Note: In order to improve EMC performance, bond the FE terminal to ground.
 Caution: FE terminal is NOT a protective conductor terminal.

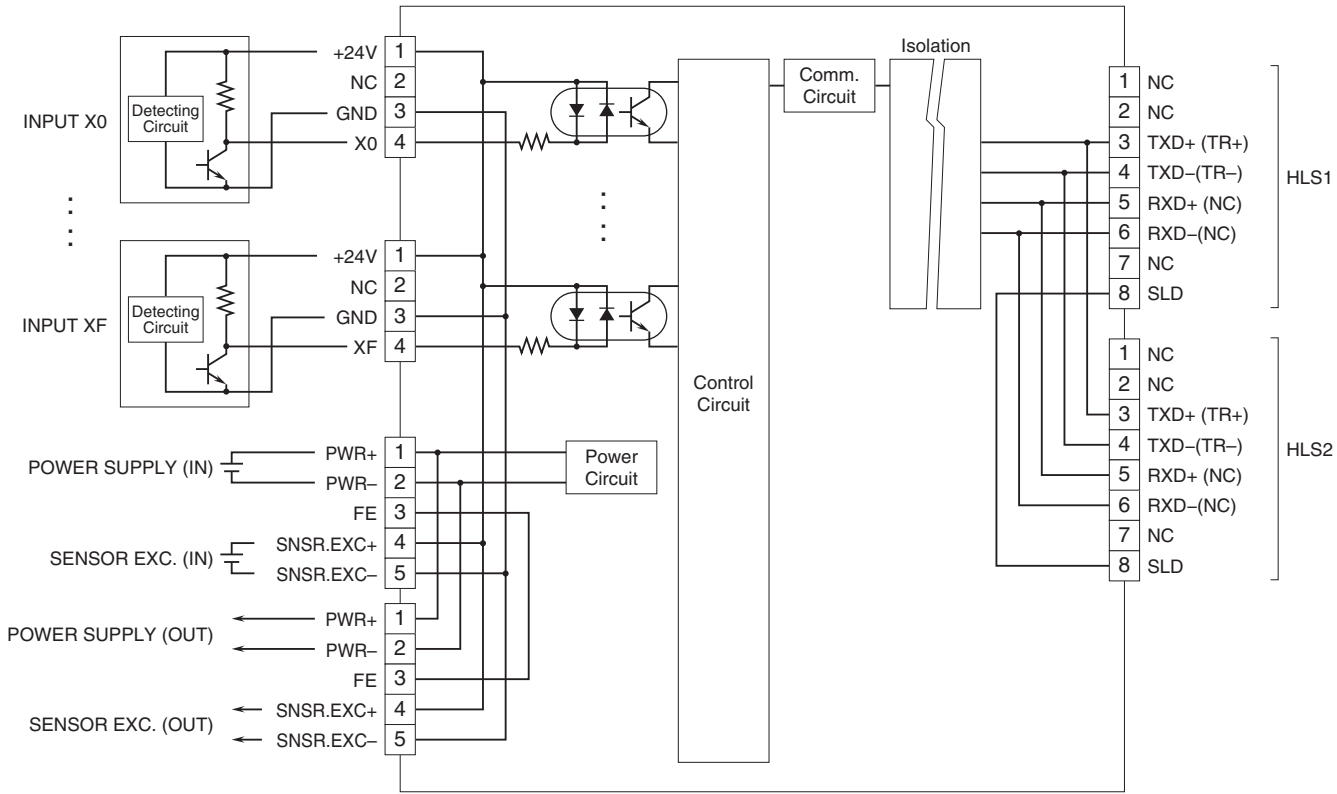

■ 2-Wire Sensor

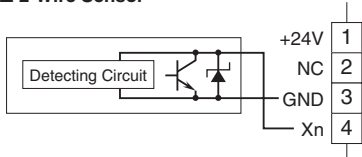

PNP DISCRETE INPUT MODULE, 16 points

(e-CON connector)

MODEL: R7F4DH-1-DA16B

SPECIFICATIONS

Common: Negative common (PNP) per 16 points

Number of I/O: Input, 16 points

Maximum inputs applicable at once: No limit (at 24 V DC)

I/O status indicator: LED turns on with closed contact.

Isolation: Input or sensor excitation to HLS to power input to FE

Data allocation: 1

Rated input voltage: 24 V DC $\pm 10\%$; ripple 5 %p-p max.

ON voltage / current: ≥ 15 V DC (input - 0V) / ≥ 3.5 mA

OFF voltage / current: ≤ 5 V DC (input - 0V) / ≤ 1 mA

Input current: ≤ 5.5 mA per point at 24 V DC

Input resistance: Approx. 4.4 k Ω

ON delay: ≤ 0.5 msec.

OFF delay: ≤ 0.5 msec.

TERMINAL ASSIGNMENTS

■ Input Connection

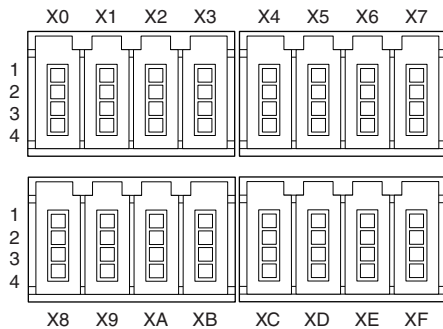

No.	ID	FUNCTION	No.	ID	FUNCTION		
X0	1	+24V	24V DC	X8	1	+24V	24V DC
	2	NC	Unused		2	NC	Unused
	3	GND	0V		3	GND	0V
	4	X0	Input 0		4	X8	Input 8
X1	1	+24V	24V DC	X9	1	+24V	24V DC
	2	NC	Unused		2	NC	Unused
	3	GND	0V		3	GND	0V
	4	X1	Input 1		4	X9	Input 9
X2	1	+24V	24V DC	XA	1	+24V	24V DC
	2	NC	Unused		2	NC	Unused
	3	GND	0V		3	GND	0V
	4	X2	Input 2		4	XA	Input 10
X3	1	+24V	24V DC	XB	1	+24V	24V DC
	2	NC	Unused		2	NC	Unused
	3	GND	0V		3	GND	0V
	4	X3	Input 3		4	XB	Input 11
X4	1	+24V	24V DC	XC	1	+24V	24V DC
	2	NC	Unused		2	NC	Unused
	3	GND	0V		3	GND	0V
	4	X4	Input 4		4	XC	Input 12
X5	1	+24V	24V DC	XD	1	+24V	24V DC
	2	NC	Unused		2	NC	Unused
	3	GND	0V		3	GND	0V
	4	X5	Input 5		4	XD	Input 13
X6	1	+24V	24V DC	XE	1	+24V	24V DC
	2	NC	Unused		2	NC	Unused
	3	GND	0V		3	GND	0V
	4	X6	Input 6		4	XE	Input 14
X7	1	+24V	24V DC	XF	1	+24V	24V DC
	2	NC	Unused		2	NC	Unused
	3	GND	0V		3	GND	0V
	4	X7	Input 7		4	XF	Input 15

SCHEMATIC CIRCUITRY

Note: In order to improve EMC performance, bond the FE terminal to ground.

Caution: FE terminal is NOT a protective conductor terminal.

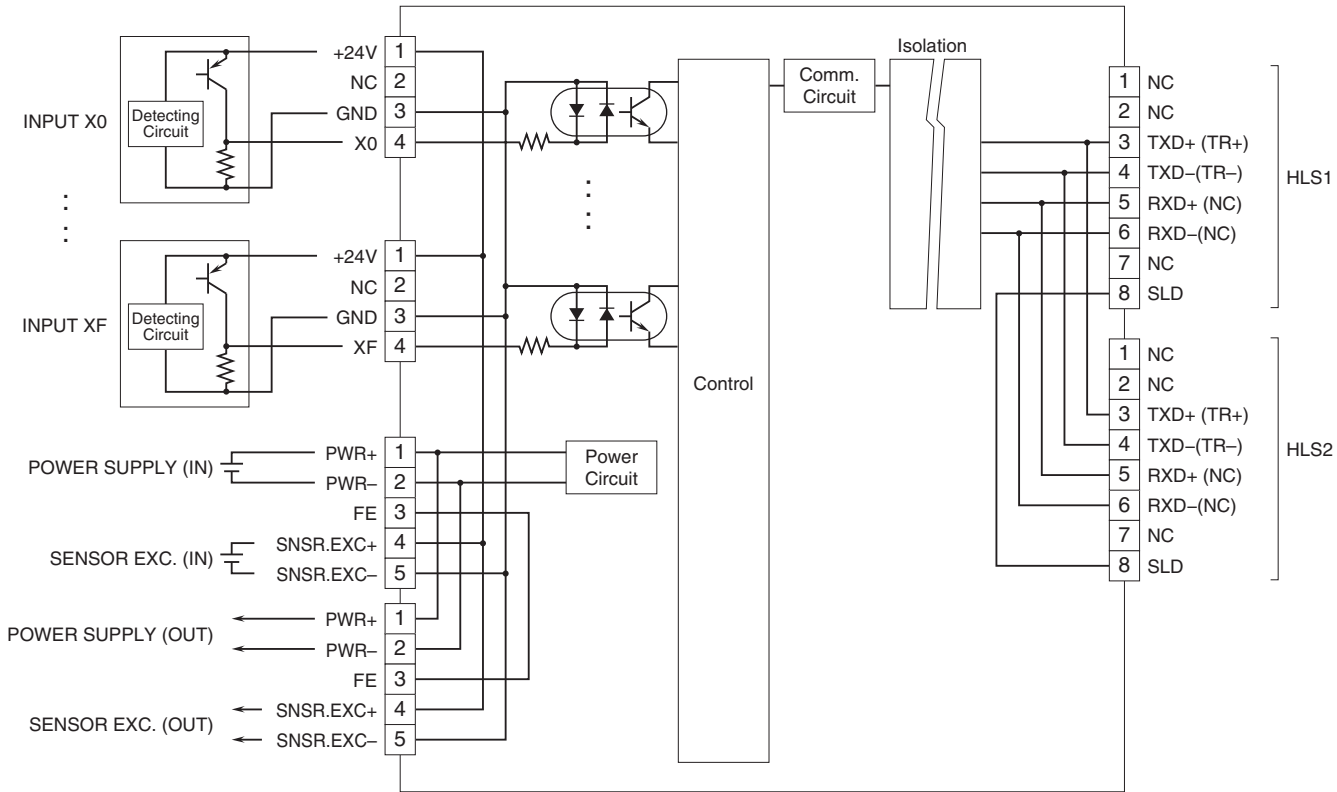

■ 2-Wire Sensor

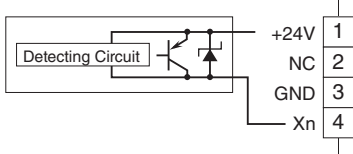

NPN TRANSISTOR OUTPUT MODULE, 16 points

(e-CON connector)

MODEL: R7F4DH-1-DC16A

SPECIFICATIONS

Common: Negative common (NPN) per 16 points

Number of I/O: Output, 16 points

Maximum outputs applicable at once: No limit (at 24 V DC)

I/O status indicator: LED turns on with closed contact.

Isolation: Output or sensor excitation to HLS to power input to FE

Data allocation: 1

Rated load voltage: 24 V AC $\pm 10\%$ (ripple 5 %p-p max.)

Rated output current: 0.1 A per point, 1.6 A per common

Residual voltage: ≤ 1.2 V

Leakage current: ≤ 0.1 mA

ON delay: ≤ 0.5 msec.

OFF delay: ≤ 0.5 msec.

Overload current protection function: Limits the current value when overcurrent is detected

Overheat Protection Function:

Turns OFF the output when overheat is detected

TERMINAL ASSIGNMENTS

■ Output Connection

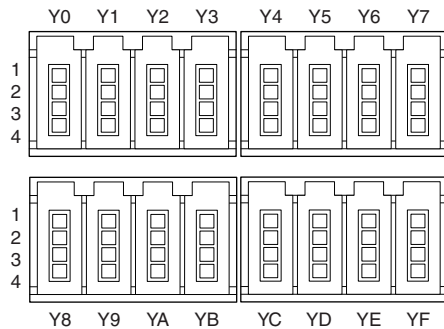

No.	ID	FUNCTION	No.	ID	FUNCTION		
Y0	1	+24V	24V DC	Y8	1	+24V	24V DC
	2	NC	Unused		2	NC	Unused
	3	GND	0V		3	GND	0V
	4	Y0	Output 0		4	Y8	Output 8
Y1	1	+24V	24V DC	Y9	1	+24V	24V DC
	2	NC	Unused		2	NC	Unused
	3	GND	0V		3	GND	0V
	4	Y1	Output 1		4	Y9	Output 9
Y2	1	+24V	24V DC	YA	1	+24V	24V DC
	2	NC	Unused		2	NC	Unused
	3	GND	0V		3	GND	0V
	4	Y2	Output 2		4	YA	Output 10
Y3	1	+24V	24V DC	YB	1	+24V	24V DC
	2	NC	Unused		2	NC	Unused
	3	GND	0V		3	GND	0V
	4	Y3	Output 3		4	YB	Output 11
Y4	1	+24V	24V DC	YC	1	+24V	24V DC
	2	NC	Unused		2	NC	Unused
	3	GND	0V		3	GND	0V
	4	Y4	Output 4		4	YC	Output 12
Y5	1	+24V	24V DC	YD	1	+24V	24V DC
	2	NC	Unused		2	NC	Unused
	3	GND	0V		3	GND	0V
	4	Y5	Output 5		4	YD	Output 13
Y6	1	+24V	24V DC	YE	1	+24V	24V DC
	2	NC	Unused		2	NC	Unused
	3	GND	0V		3	GND	0V
	4	Y6	Output 6		4	YE	Output 14
Y7	1	+24V	24V DC	YF	1	+24V	24V DC
	2	NC	Unused		2	NC	Unused
	3	GND	0V		3	GND	0V
	4	Y7	Output 7		4	YF	Output 15

SCHEMATIC CIRCUITRY

Note: In order to improve EMC performance, bond the FE terminal to ground.

Caution: FE terminal is NOT a protective conductor terminal.

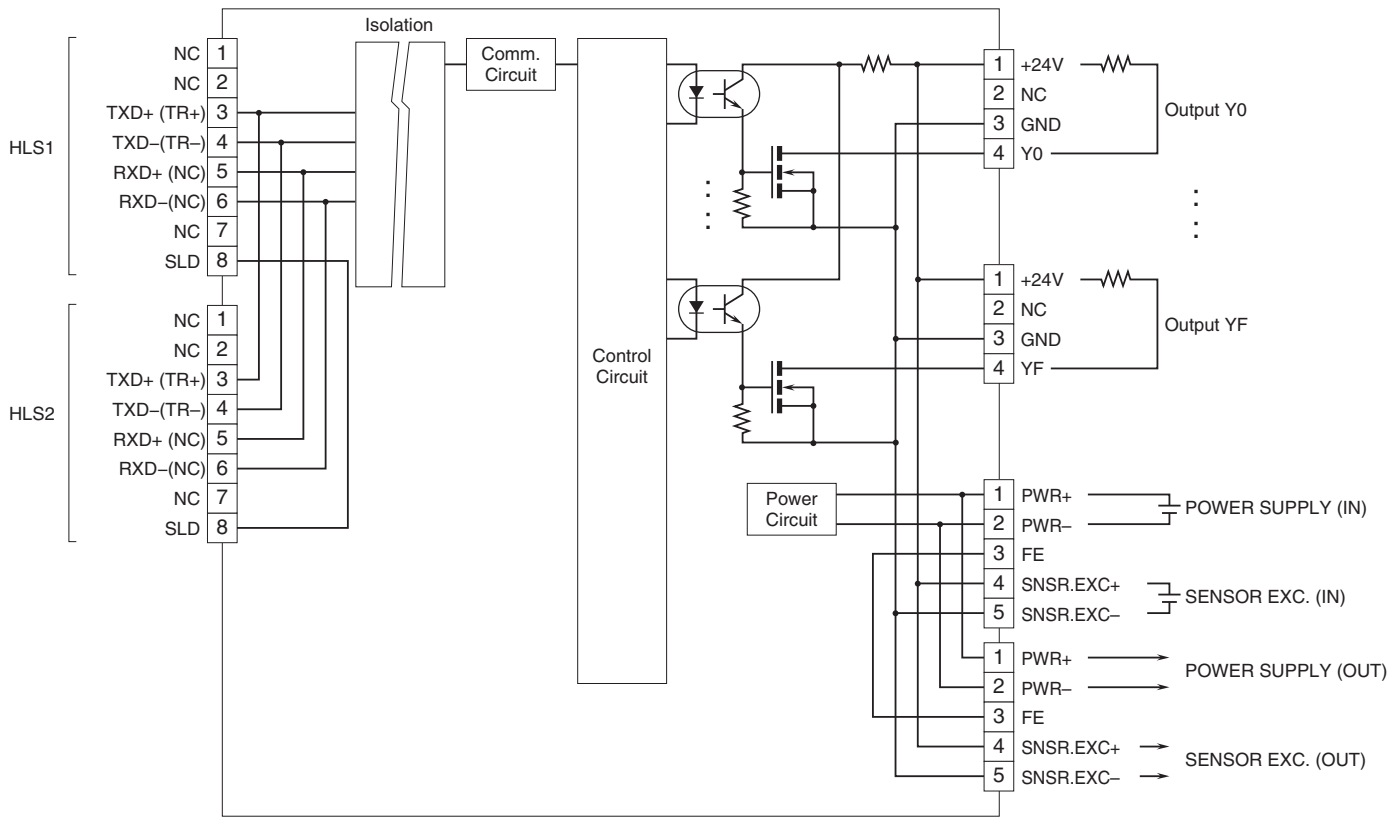

PNP TRANSISTOR OUTPUT MODULE, 16 points

(e-CON connector)

MODEL: R7F4DH-1-DC16B

SPECIFICATIONS

Common: Positive common (PNP) per 16 points

Number of I/O: Output, 16 points

Maximum outputs applicable at once: No limit (at 24 V DC)

I/O status indicator: LED turns on with closed contact.

Isolation: Output or sensor excitation to HLS to power input to FE

Data allocation: 1

Rated load voltage: 24 V AC $\pm 10\%$ (ripple 5 %p-p max.)

Rated output current: 0.1 A per point, 1.6 A per common

Residual voltage: ≤ 1.2 V

Leakage current: ≤ 0.1 mA

ON delay: ≤ 0.5 msec.

OFF delay: ≤ 0.5 msec.

Overload current protection function: Limits the current value when overcurrent is detected

Overheat Protection Function:

Turns OFF the output when overheat is detected

TERMINAL ASSIGNMENTS

■ Output Connection

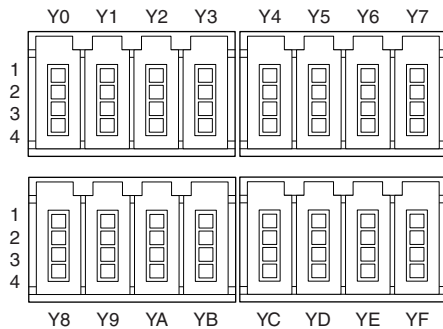

No.	ID	FUNCTION	No.	ID	FUNCTION		
Y0	1	+24V	24V DC	Y8	1	+24V	24V DC
	2	NC	Unused		2	NC	Unused
	3	GND	0V		3	GND	0V
	4	Y0	Output 0		4	Y8	Output 8
Y1	1	+24V	24V DC	Y9	1	+24V	24V DC
	2	NC	Unused		2	NC	Unused
	3	GND	0V		3	GND	0V
	4	Y1	Output 1		4	Y9	Output 9
Y2	1	+24V	24V DC	YA	1	+24V	24V DC
	2	NC	Unused		2	NC	Unused
	3	GND	0V		3	GND	0V
	4	Y2	Output 2		4	YA	Output 10
Y3	1	+24V	24V DC	YB	1	+24V	24V DC
	2	NC	Unused		2	NC	Unused
	3	GND	0V		3	GND	0V
	4	Y3	Output 3		4	YB	Output 11
Y4	1	+24V	24V DC	YC	1	+24V	24V DC
	2	NC	Unused		2	NC	Unused
	3	GND	0V		3	GND	0V
	4	Y4	Output 4		4	YC	Output 12
Y5	1	+24V	24V DC	YD	1	+24V	24V DC
	2	NC	Unused		2	NC	Unused
	3	GND	0V		3	GND	0V
	4	Y5	Output 5		4	YD	Output 13
Y6	1	+24V	24V DC	YE	1	+24V	24V DC
	2	NC	Unused		2	NC	Unused
	3	GND	0V		3	GND	0V
	4	Y6	Output 6		4	YE	Output 14
Y7	1	+24V	24V DC	YF	1	+24V	24V DC
	2	NC	Unused		2	NC	Unused
	3	GND	0V		3	GND	0V
	4	Y7	Output 7		4	YF	Output 15

SCHEMATIC CIRCUITRY

Note: In order to improve EMC performance, bond the FE terminal to ground.

Caution: FE terminal is NOT a protective conductor terminal.

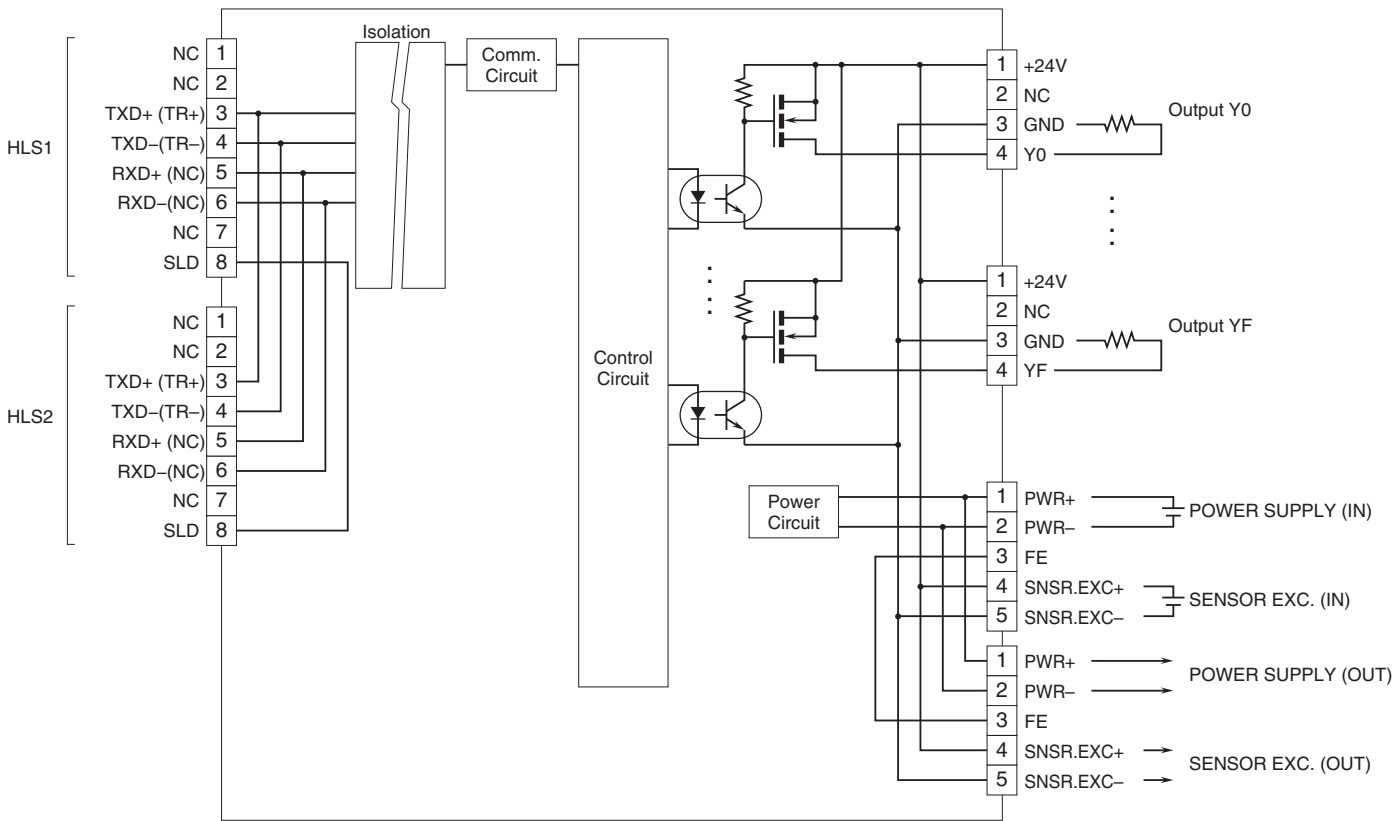

**PNP DISCRETE INPUT &
NPN TRANSISTOR OUTPUT MODULE, 8 points each**
(e-CON connector)

MODEL: R7F4DH-1-DAC16A

SPECIFICATIONS

■ COMMON SPECIFICATIONS

Common: Negative common per 16 points
Input rating/load voltage: 24 V DC $\pm 10\%$, ripple 5 %p-p max.
Number of I/O: Input, 8 points; Output, 8 points
Maximum I/O applicable at once: No limit (at 24 V DC)
I/O status indicator: LED turns on with closed contact.
Isolation: I/O or sensor excitation to HLS to power input to FE
Data allocation: 1

■ INPUT

ON voltage / current: ≥ 15 V DC (I/O's X0 through X7 to 0 V) / ≥ 3.5 mA
OFF voltage / current: ≤ 5 V DC (I/O's X0 through X7 to 0 V) / ≤ 1 mA
Input current: ≤ 5.5 mA per point at 24 V DC
Input resistance: Approx. 4.4 k Ω
ON delay: ≤ 0.5 msec.
OFF delay: ≤ 0.5 msec.

■ OUTPUT

Rated output current: 0.1 A per point, 0.8 A per common
Residual voltage: ≤ 1.2 V
Leakage current: ≤ 0.1 mA
ON delay: ≤ 0.5 msec.
OFF delay: ≤ 0.5 msec.
Overload current protection function: Limits the current value when overcurrent is detected
Overheat Protection Function:
 Turns OFF the output when overheat is detected

No.	ID	FUNCTION	No.	ID	FUNCTION
X0	1	+24V 24V DC	Y0	1	+24V 24V DC
	2	NC Unused		2	NC Unused
	3	GND 0V		3	GND 0V
	4	X0 Input 0		4	Y0 Output 0
X1	1	+24V 24V DC	Y1	1	+24V 24V DC
	2	NC Unused		2	NC Unused
	3	GND 0V		3	GND 0V
	4	X1 Input 1		4	Y1 Output 1
X2	1	+24V 24V DC	Y2	1	+24V 24V DC
	2	NC Unused		2	NC Unused
	3	GND 0V		3	GND 0V
	4	X2 Input 2		4	Y2 Output 2
X3	1	+24V 24V DC	Y3	1	+24V 24V DC
	2	NC Unused		2	NC Unused
	3	GND 0V		3	GND 0V
	4	X3 Input 3		4	Y3 Output 3
X4	1	+24V 24V DC	Y4	1	+24V 24V DC
	2	NC Unused		2	NC Unused
	3	GND 0V		3	GND 0V
	4	X4 Input 4		4	Y4 Output 4
X5	1	+24V 24V DC	Y5	1	+24V 24V DC
	2	NC Unused		2	NC Unused
	3	GND 0V		3	GND 0V
	4	X5 Input 5		4	Y5 Output 5
X6	1	+24V 24V DC	Y6	1	+24V 24V DC
	2	NC Unused		2	NC Unused
	3	GND 0V		3	GND 0V
	4	X6 Input 6		4	Y6 Output 6
X7	1	+24V 24V DC	Y7	1	+24V 24V DC
	2	NC Unused		2	NC Unused
	3	GND 0V		3	GND 0V
	4	X7 Input 7		4	Y7 Output 7

TERMINAL ASSIGNMENTS

■ I/O Connection

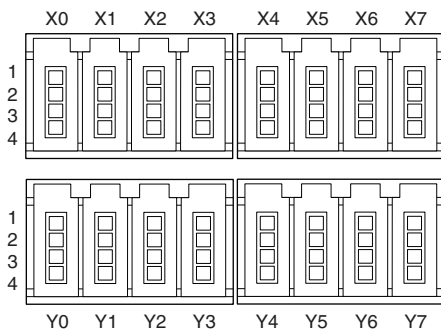

SCHEMATIC CIRCUITRY

Note: In order to improve EMC performance, bond the FE terminal to ground.

Caution: FE terminal is NOT a protective conductor terminal.

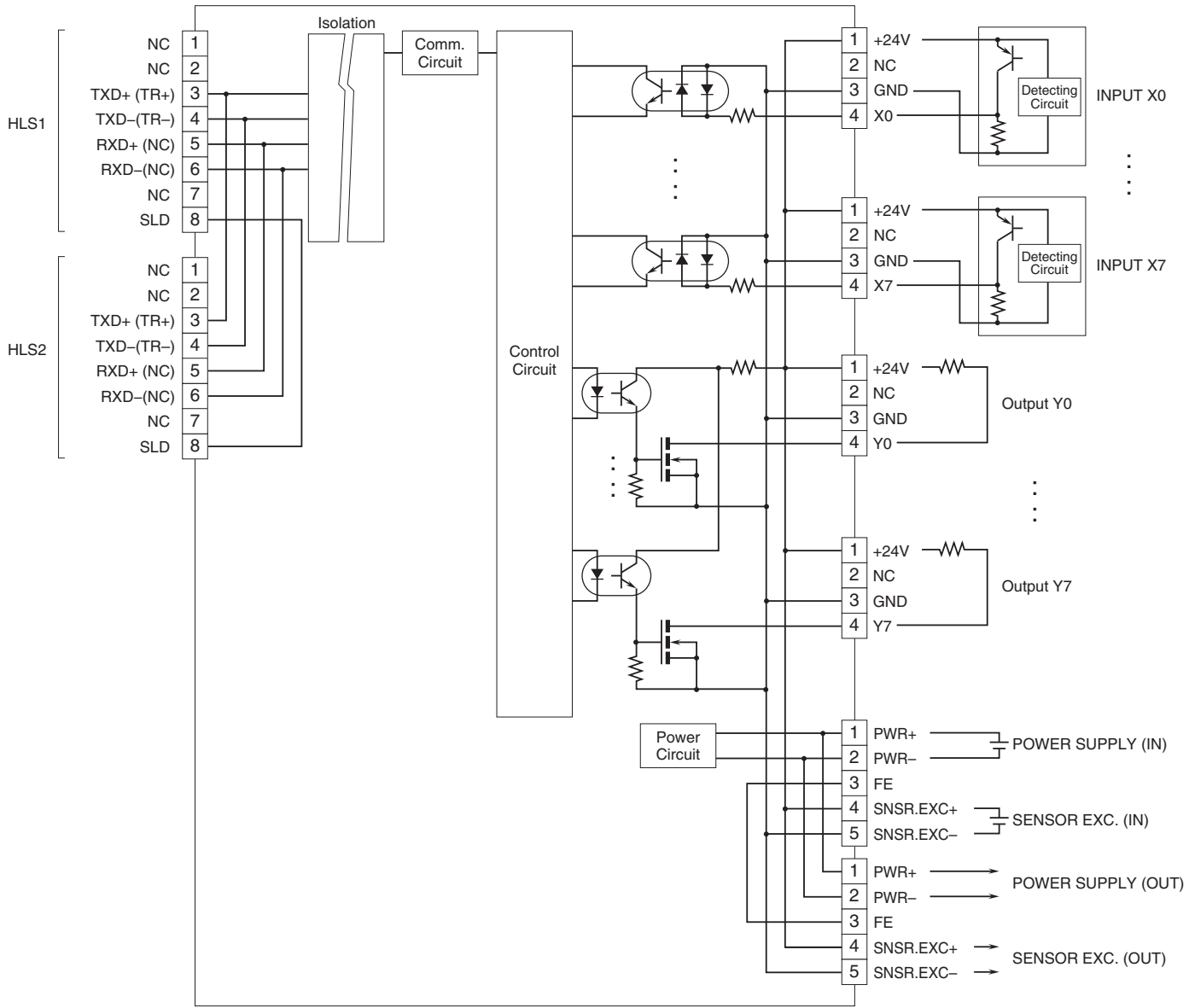

■ 2-Wire Sensor

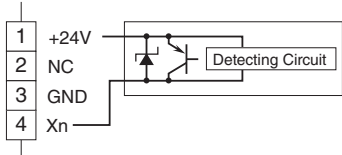

NPN DISCRETE INPUT & PNP TRANSISTOR OUTPUT MODULE, 8 points each
(e-CON connector)

MODEL: R7F4DH-1-DAC16B

SPECIFICATIONS

■ COMMON SPECIFICATIONS

- Common: Positive common per 16 points
- Input rating/load voltage: 24 V DC $\pm 10\%$, ripple 5 %p-p max.
- Number of I/O: Input, 8 points; Output, 8 points
- Maximum I/O applicable at once: No limit (at 24 V DC)
- I/O status indicator: LED turns on with closed contact.
- Isolation: I/O or sensor excitation to HLS to power input to FE
- Data allocation: 1
- INPUT
- ON voltage / current: ≥ 15 V DC (I/O's X0 through X7 to +24 V) / ≥ 3.5 mA
- OFF voltage / current: ≤ 5 V DC (I/O's X0 through X7 to +24 V) / ≤ 1 mA
- Input current: ≤ 5.5 mA per point at 24 V DC
- Input resistance: Approx. 4.4 k Ω
- ON delay: ≤ 0.5 msec.
- OFF delay: ≤ 0.5 msec.
- OUTPUT
- Rated output current: 0.1 A per point, 0.8 A per common
- Residual voltage: ≤ 1.2 V
- Leakage current: ≤ 0.1 mA
- ON delay: ≤ 0.5 msec.
- OFF delay: ≤ 0.5 msec.
- Overload current protection function: Limits the current value when overcurrent is detected
- Overheat Protection Function:
Turns OFF the output when overheat is detected

No.	ID	FUNCTION	No.	ID	FUNCTION
X0	1	+24V 24V DC	Y0	1	+24V 24V DC
	2	NC Unused		2	NC Unused
	3	GND 0V		3	GND 0V
	4	X0 Input 0		4	Y0 Output 0
X1	1	+24V 24V DC	Y1	1	+24V 24V DC
	2	NC Unused		2	NC Unused
	3	GND 0V		3	GND 0V
	4	X1 Input 1		4	Y1 Output 1
X2	1	+24V 24V DC	Y2	1	+24V 24V DC
	2	NC Unused		2	NC Unused
	3	GND 0V		3	GND 0V
	4	X2 Input 2		4	Y2 Output 2
X3	1	+24V 24V DC	Y3	1	+24V 24V DC
	2	NC Unused		2	NC Unused
	3	GND 0V		3	GND 0V
	4	X3 Input 3		4	Y3 Output 3
X4	1	+24V 24V DC	Y4	1	+24V 24V DC
	2	NC Unused		2	NC Unused
	3	GND 0V		3	GND 0V
	4	X4 Input 4		4	Y4 Output 4
X5	1	+24V 24V DC	Y5	1	+24V 24V DC
	2	NC Unused		2	NC Unused
	3	GND 0V		3	GND 0V
	4	X5 Input 5		4	Y5 Output 5
X6	1	+24V 24V DC	Y6	1	+24V 24V DC
	2	NC Unused		2	NC Unused
	3	GND 0V		3	GND 0V
	4	X6 Input 6		4	Y6 Output 6
X7	1	+24V 24V DC	Y7	1	+24V 24V DC
	2	NC Unused		2	NC Unused
	3	GND 0V		3	GND 0V
	4	X7 Input 7		4	Y7 Output 7

TERMINAL ASSIGNMENTS

■ I/O Connection

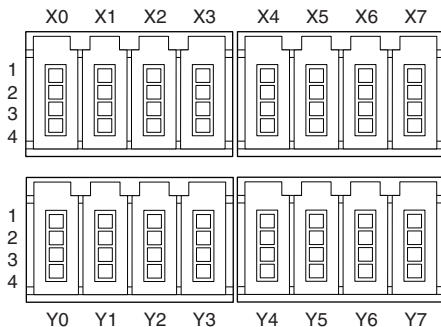

SCHEMATIC CIRCUITRY

Note: In order to improve EMC performance, bond the FE terminal to ground.

Caution: FE terminal is NOT a protective conductor terminal.

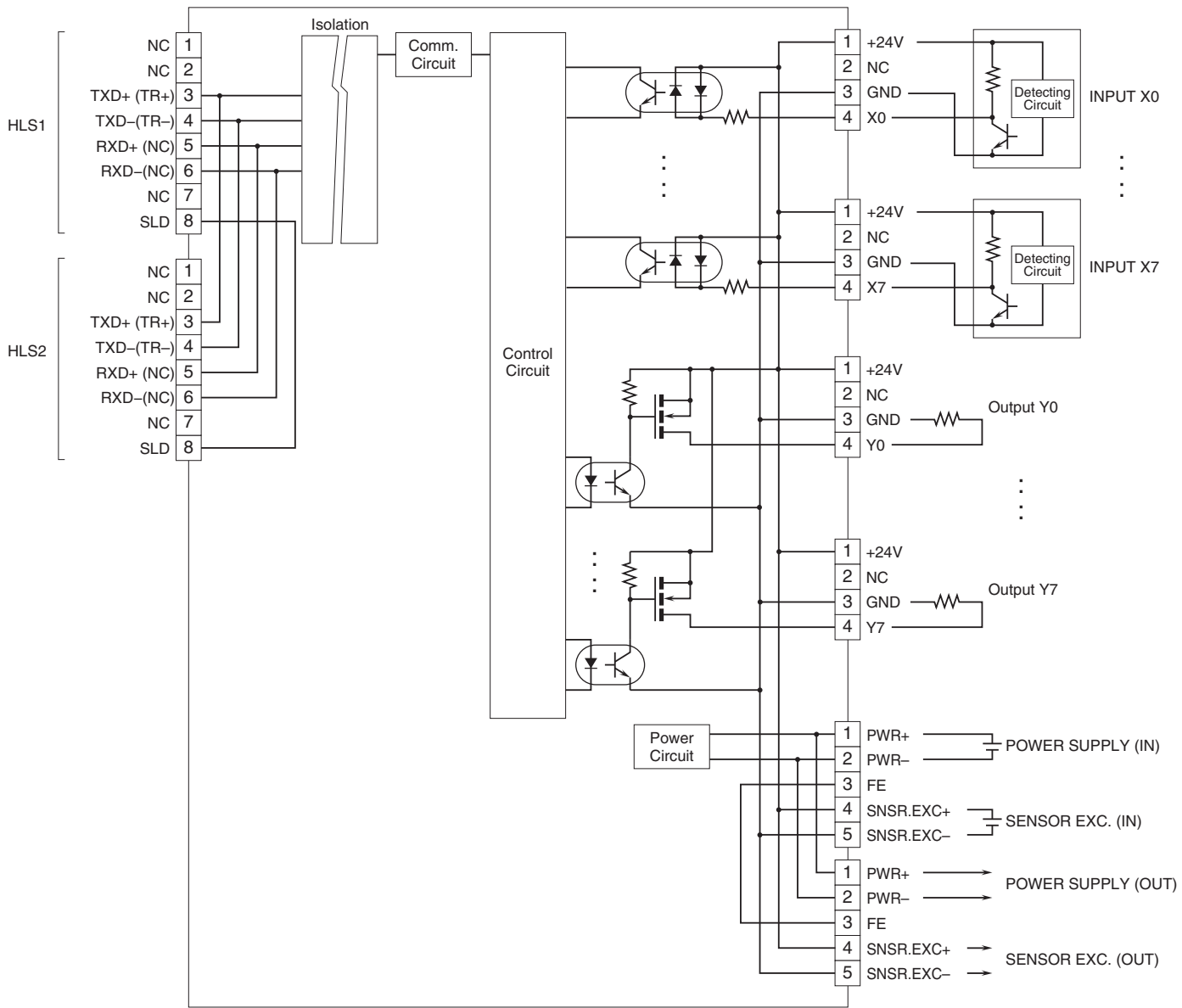

■ 2-Wire Sensor

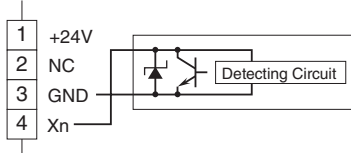

NPN DISCRETE INPUT & NPN TRANSISTOR OUTPUT MODULE, 8 points each (e-CON connector)

MODEL: R7F4DH-1-DAC16C

SPECIFICATIONS

COMMON SPECIFICATIONS

- Input common:** Positive common per 8 points
- Output common:** Negative common per 8 points
- Input rating/load voltage:** 24 V DC $\pm 10\%$, ripple 5 %p-p max.
- Number of I/O:** Input, 8 points; Output, 8 points
- Maximum I/O applicable at once:** No limit (at 24 V DC)
- I/O status indicator:** LED turns on with closed contact.
- Isolation:** I/O or sensor excitation to HLS to power input to FE
- Data allocation:** 1
- ##### INPUT

 - ON voltage / current:** ≥ 15 V DC (I/O's X0 through X7 to +24 V) / ≥ 3.5 mA
 - OFF voltage / current:** ≤ 5 V DC (I/O's X0 through X7 to +24 V) / ≤ 1 mA
 - Input current:** ≤ 5.5 mA per point at 24 V DC
 - Input resistance:** Approx. 4.4 k Ω
 - ON delay:** ≤ 0.5 msec.
 - OFF delay:** ≤ 0.5 msec.
- ##### OUTPUT

 - Rated output current:** 0.1 A per point, 0.8 A per common
 - Residual voltage:** ≤ 1.2 V
 - Leakage current:** ≤ 0.1 mA
 - ON delay:** ≤ 0.5 msec.
 - OFF delay:** ≤ 0.5 msec.
 - Overload current protection function:** Limits the current value when overcurrent is detected
 - Overheat Protection Function:**
Turns OFF the output when overheat is detected

No.	ID	FUNCTION	No.	ID	FUNCTION
X0	1	+24V 24V DC	Y0	1	+24V 24V DC
	2	NC Unused		2	NC Unused
	3	GND 0V		3	GND 0V
	4	X0 Input 0		4	Y0 Output 0
X1	1	+24V 24V DC	Y1	1	+24V 24V DC
	2	NC Unused		2	NC Unused
	3	GND 0V		3	GND 0V
	4	X1 Input 1		4	Y1 Output 1
X2	1	+24V 24V DC	Y2	1	+24V 24V DC
	2	NC Unused		2	NC Unused
	3	GND 0V		3	GND 0V
	4	X2 Input 2		4	Y2 Output 2
X3	1	+24V 24V DC	Y3	1	+24V 24V DC
	2	NC Unused		2	NC Unused
	3	GND 0V		3	GND 0V
	4	X3 Input 3		4	Y3 Output 3
X4	1	+24V 24V DC	Y4	1	+24V 24V DC
	2	NC Unused		2	NC Unused
	3	GND 0V		3	GND 0V
	4	X4 Input 4		4	Y4 Output 4
X5	1	+24V 24V DC	Y5	1	+24V 24V DC
	2	NC Unused		2	NC Unused
	3	GND 0V		3	GND 0V
	4	X5 Input 5		4	Y5 Output 5
X6	1	+24V 24V DC	Y6	1	+24V 24V DC
	2	NC Unused		2	NC Unused
	3	GND 0V		3	GND 0V
	4	X6 Input 6		4	Y6 Output 6
X7	1	+24V 24V DC	Y7	1	+24V 24V DC
	2	NC Unused		2	NC Unused
	3	GND 0V		3	GND 0V
	4	X7 Input 7		4	Y7 Output 7

TERMINAL ASSIGNMENTS

I/O Connection

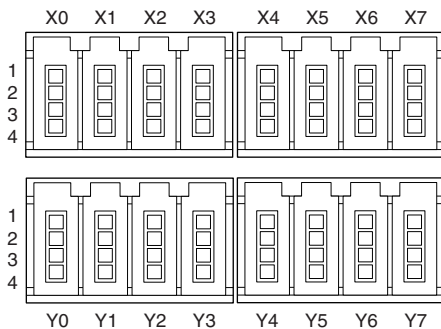

SCHEMATIC CIRCUITRY

Note: In order to improve EMC performance, bond the FE terminal to ground.
 Caution: FE terminal is NOT a protective conductor terminal.

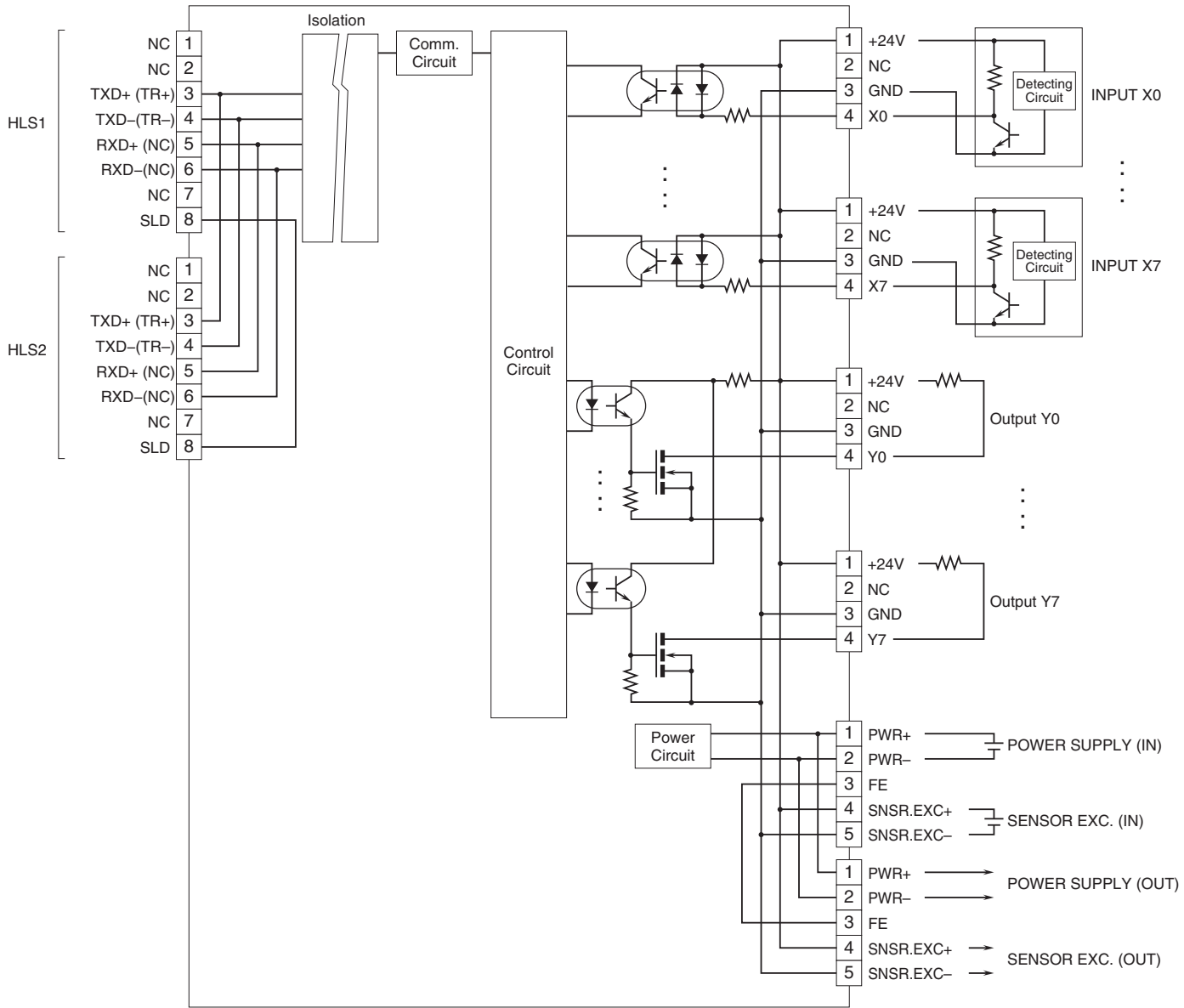

■ 2-Wire Sensor

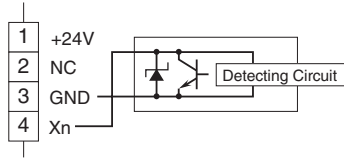

PNP DISCRETE INPUT & PNP TRANSISTOR OUTPUT MODULE, 8 points each (e-CON connector)

MODEL: R7F4DH-1-DAC16D

SPECIFICATIONS

COMMON SPECIFICATIONS

- Input common:** Negative common per 8 points
- Output common:** Positive common per 8 points
- Input rating/load voltage:** 24 V DC $\pm 10\%$, ripple 5 %p-p max.
- Number of I/O:** Input, 8 points; Output, 8 points
- Maximum I/O applicable at once:** No limit (at 24 V DC)
- I/O status indicator:** LED turns on with closed contact.
- Isolation:** I/O or sensor excitation to HLS to power input to FE
- Data allocation:** 1
- ##### INPUT

 - ON voltage / current:** ≥ 15 V DC (I/O's X0 through X7 to 0 V) / ≥ 3.5 mA
 - OFF voltage / current:** ≤ 5 V DC (I/O's X0 through X7 to 0 V) / ≤ 1 mA
 - Input current:** ≤ 5.5 mA per point at 24 V DC
 - Input resistance:** Approx. 4.4 k Ω
 - ON delay:** ≤ 0.5 msec.
 - OFF delay:** ≤ 0.5 msec.
- ##### OUTPUT

 - Rated output current:** 0.1 A per point, 0.8 A per common
 - Residual voltage:** ≤ 1.2 V
 - Leakage current:** ≤ 0.1 mA
 - ON delay:** ≤ 0.5 msec.
 - OFF delay:** ≤ 0.5 msec.
 - Overload current protection function:** Limits the current value when overcurrent is detected
 - Overheat Protection Function:** Turns OFF the output when overheat is detected

No.	ID	FUNCTION	No.	ID	FUNCTION
X0	1	+24V 24V DC	Y0	1	+24V 24V DC
	2	NC Unused		2	NC Unused
	3	GND 0V		3	GND 0V
	4	X0 Input 0		4	Y0 Output 0
X1	1	+24V 24V DC	Y1	1	+24V 24V DC
	2	NC Unused		2	NC Unused
	3	GND 0V		3	GND 0V
	4	X1 Input 1		4	Y1 Output 1
X2	1	+24V 24V DC	Y2	1	+24V 24V DC
	2	NC Unused		2	NC Unused
	3	GND 0V		3	GND 0V
	4	X2 Input 2		4	Y2 Output 2
X3	1	+24V 24V DC	Y3	1	+24V 24V DC
	2	NC Unused		2	NC Unused
	3	GND 0V		3	GND 0V
	4	X3 Input 3		4	Y3 Output 3
X4	1	+24V 24V DC	Y4	1	+24V 24V DC
	2	NC Unused		2	NC Unused
	3	GND 0V		3	GND 0V
	4	X4 Input 4		4	Y4 Output 4
X5	1	+24V 24V DC	Y5	1	+24V 24V DC
	2	NC Unused		2	NC Unused
	3	GND 0V		3	GND 0V
	4	X5 Input 5		4	Y5 Output 5
X6	1	+24V 24V DC	Y6	1	+24V 24V DC
	2	NC Unused		2	NC Unused
	3	GND 0V		3	GND 0V
	4	X6 Input 6		4	Y6 Output 6
X7	1	+24V 24V DC	Y7	1	+24V 24V DC
	2	NC Unused		2	NC Unused
	3	GND 0V		3	GND 0V
	4	X7 Input 7		4	Y7 Output 7

TERMINAL ASSIGNMENTS

I/O Connection

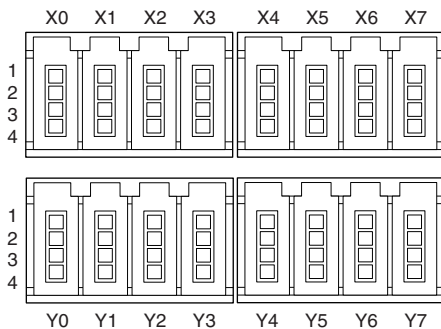

SCHEMATIC CIRCUITRY

Note: In order to improve EMC performance, bond the FE terminal to ground.

Caution: FE terminal is NOT a protective conductor terminal.

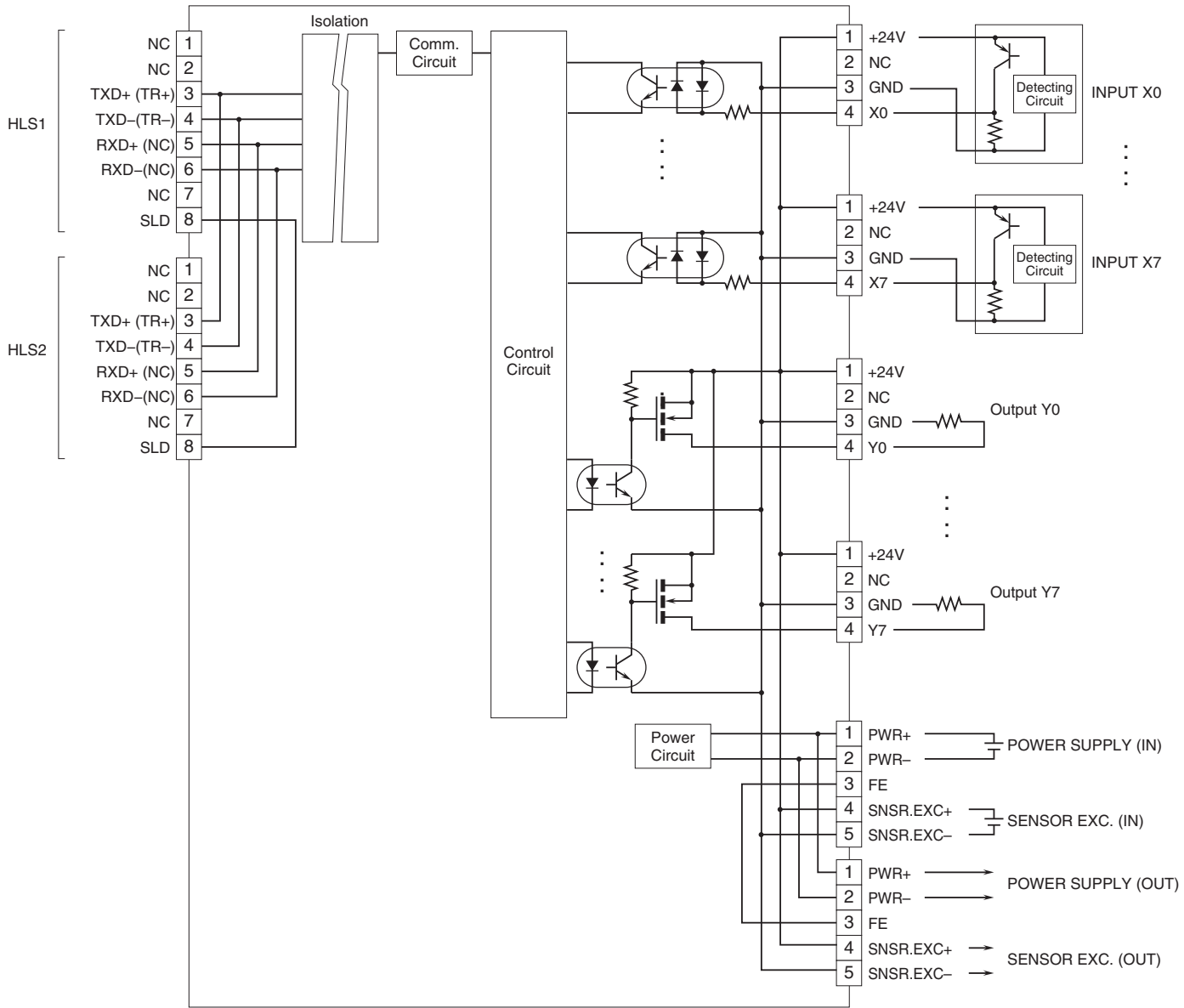

2-Wire Sensor

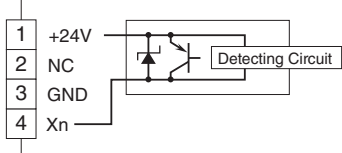

NPN DISCRETE INPUT MODULE, 16 points

(MIL connector)

MODEL:

R7F4DH-2-DA16A

R7F4DH-3-DA16A

SPECIFICATIONS

Common: Positive common (NPN) per 16 points

Number of I/O: Input, 16 points

Maximum inputs applicable at once: No limit (at 24 V DC)

I/O status indicator: LED turns on with closed contact.

Isolation: Input or sensor excitation to HLS to power input to FE

Data allocation: 1

Rated input voltage: 24 V DC $\pm 10\%$; ripple 5 %p-p max.

ON voltage / current: ≥ 15 V DC (input - +24V) / ≥ 3.5 mA

OFF voltage / current: ≤ 5 V DC (input - +24V) / ≤ 1 mA

Input current: ≤ 5.5 mA per point at 24 V DC

Input resistance: Approx. 4.4 k Ω

ON delay: ≤ 0.5 msec.

OFF delay: ≤ 0.5 msec.

TERMINAL ASSIGNMENTS

■ Input Connection

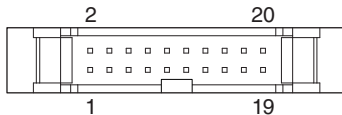

1. Terminal block code 2

PIN No	ID	FUNCTION	PIN No	ID	FUNCTION
1	X0	Input 0	11	XA	Input 10
2	X1	Input 1	12	XB	Input 11
3	X2	Input 2	13	XC	Input 12
4	X3	Input 3	14	XD	Input 13
5	X4	Input 4	15	XE	Input 14
6	X5	Input 5	16	XF	Input 15
7	X6	Input 6	17	GND	0V
8	X7	Input 7	18	GND	0V
9	X8	Input 8	19	+24V	24VDC
10	X9	Input 9	20	+24V	24VDC

2. Terminal block code 3

PIN No	ID	FUNCTION	PIN No	ID	FUNCTION
1	+24V	24VDC	11	XC	Input 12
2	+24V	24VDC	12	X4	Input 4
3	GND	0V	13	XB	Input 11
4	GND	0V	14	X3	Input 3
5	XF	Input 15	15	XA	Input 10
6	X7	Input 7	16	X2	Input 2
7	XE	Input 14	17	X9	Input 9
8	X6	Input 6	18	X1	Input 1
9	XD	Input 13	19	X8	Input 8
10	X5	Input 5	20	X0	Input 0

SCHEMATIC CIRCUITRY

Note: In order to improve EMC performance, bond the FE terminal to ground.

Caution: FE terminal is NOT a protective conductor terminal.

■ TERMINAL CODE 2

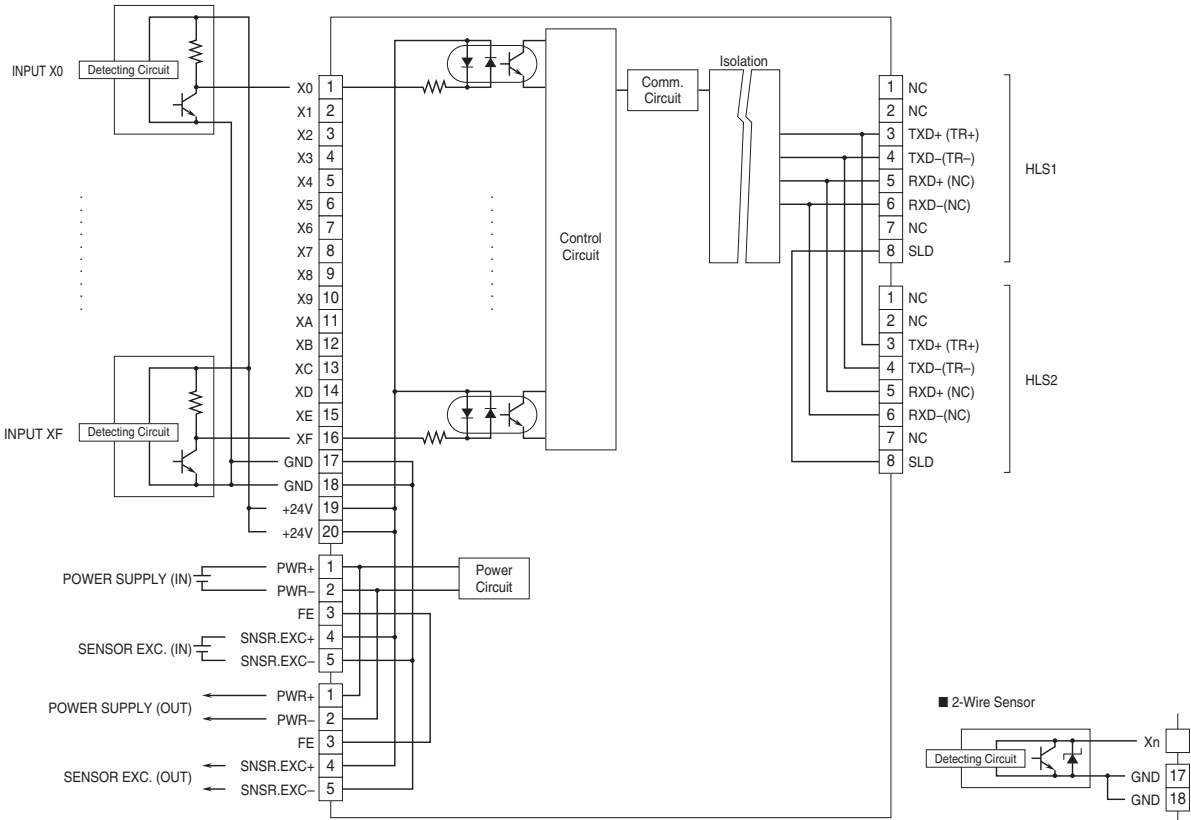

■ TERMINAL CODE 3

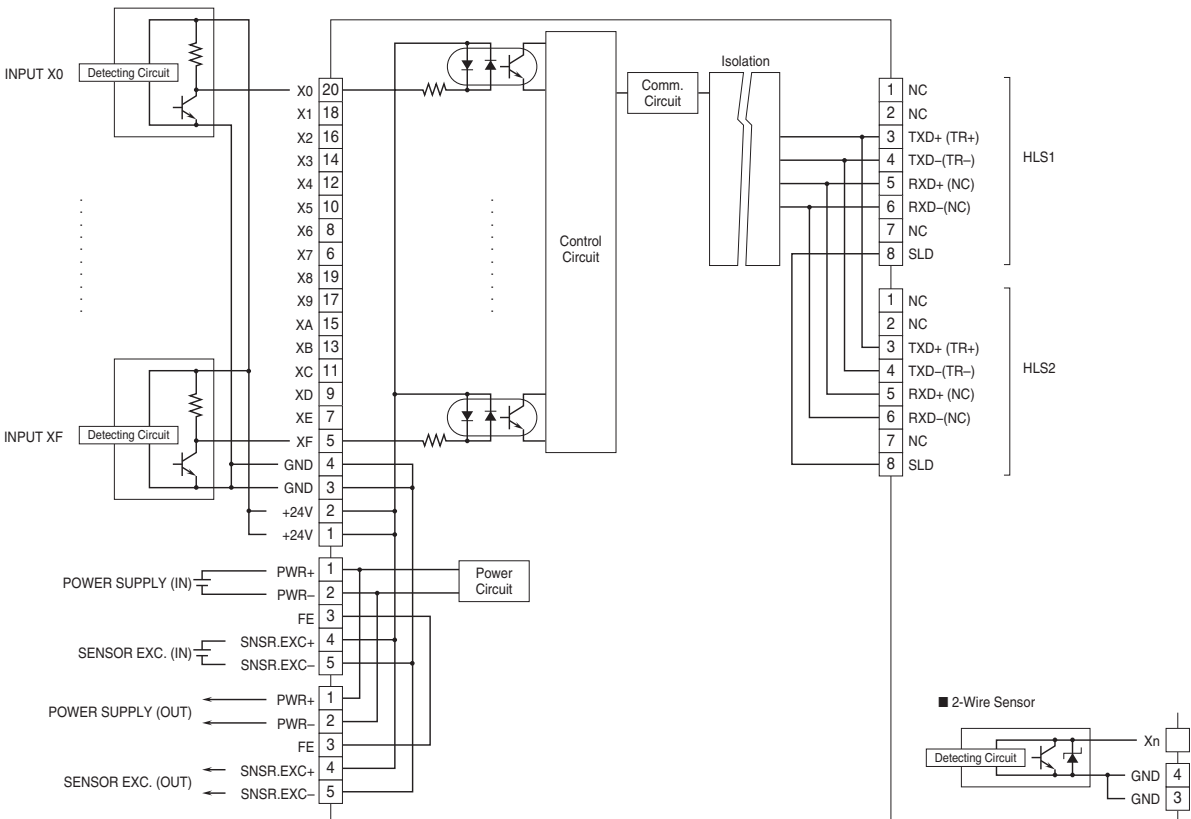

PNP DISCRETE INPUT MODULE, 16 points

(MIL connector)

MODEL:

R7F4DH-2-DA16B

R7F4DH-3-DA16B

SPECIFICATIONS

Common: Negative common (PNP) per 16 points

Number of I/O: Input, 16 points

Maximum inputs applicable at once: No limit (at 24 V DC)

I/O status indicator: LED turns on with closed contact.

Isolation: Input or sensor excitation to HLS to power input to FE

Data allocation: 1

Rated input voltage: 24 V DC $\pm 10\%$; ripple 5 %p-p max.

ON voltage / current: ≥ 15 V DC (input - 0V) / ≥ 3.5 mA

OFF voltage / current: ≤ 5 V DC (input - 0V) / ≤ 1 mA

Input current: ≤ 5.5 mA per point at 24 V DC

Input resistance: Approx. 4.4 k Ω

ON delay: ≤ 0.5 msec.

OFF delay: ≤ 0.5 msec.

TERMINAL ASSIGNMENTS

■ Input Connection

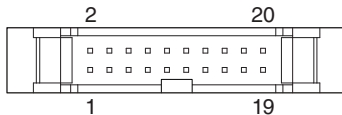

1. Terminal block code 2

PIN No	ID	FUNCTION	PIN No	ID	FUNCTION
1	X0	Input 0	11	XA	Input 10
2	X1	Input 1	12	XB	Input 11
3	X2	Input 2	13	XC	Input 12
4	X3	Input 3	14	XD	Input 13
5	X4	Input 4	15	XE	Input 14
6	X5	Input 5	16	XF	Input 15
7	X6	Input 6	17	GND	0V
8	X7	Input 7	18	GND	0V
9	X8	Input 8	19	+24V	24VDC
10	X9	Input 9	20	+24V	24VDC

2. Terminal block code 3

PIN No	ID	FUNCTION	PIN No	ID	FUNCTION
1	+24V	24VDC	11	XC	Input 12
2	+24V	24VDC	12	X4	Input 4
3	GND	0V	13	XB	Input 11
4	GND	0V	14	X3	Input 3
5	XF	Input 15	15	XA	Input 10
6	X7	Input 7	16	X2	Input 2
7	XE	Input 14	17	X9	Input 9
8	X6	Input 6	18	X1	Input 1
9	XD	Input 13	19	X8	Input 8
10	X5	Input 5	20	X0	Input 0

SCHEMATIC CIRCUITRY

Note: In order to improve EMC performance, bond the FE terminal to ground.
 Caution: FE terminal is NOT a protective conductor terminal.

■ TERMINAL CODE 2

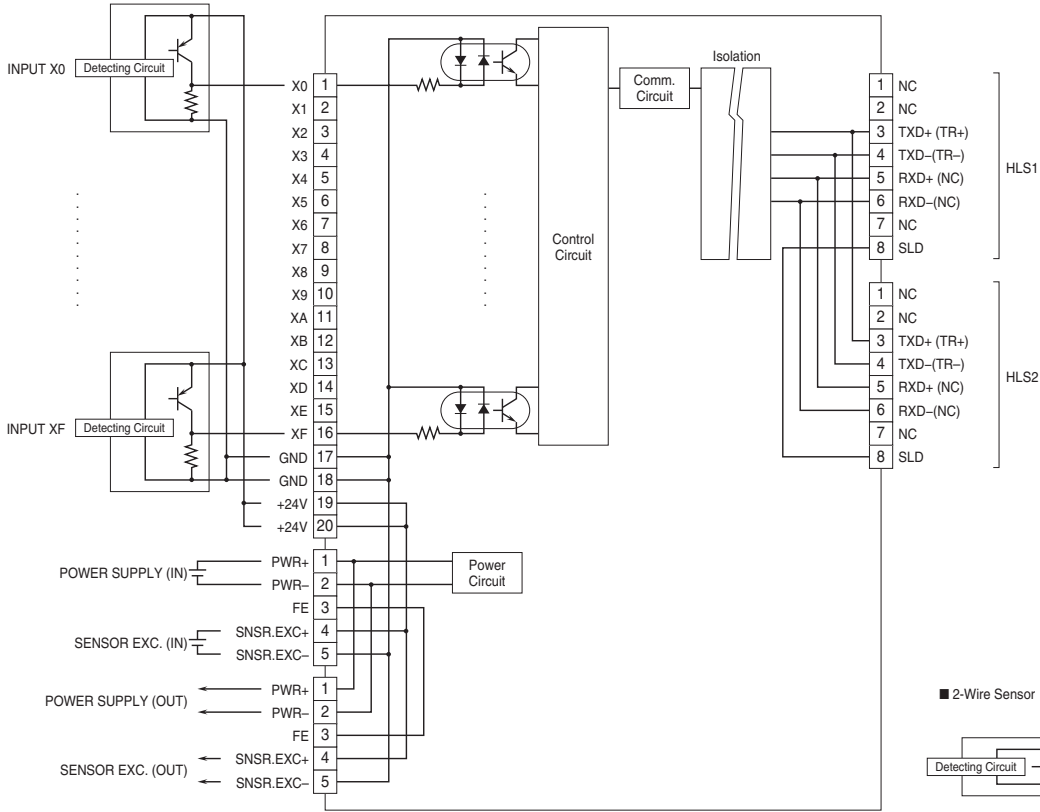

■ TERMINAL CODE 3

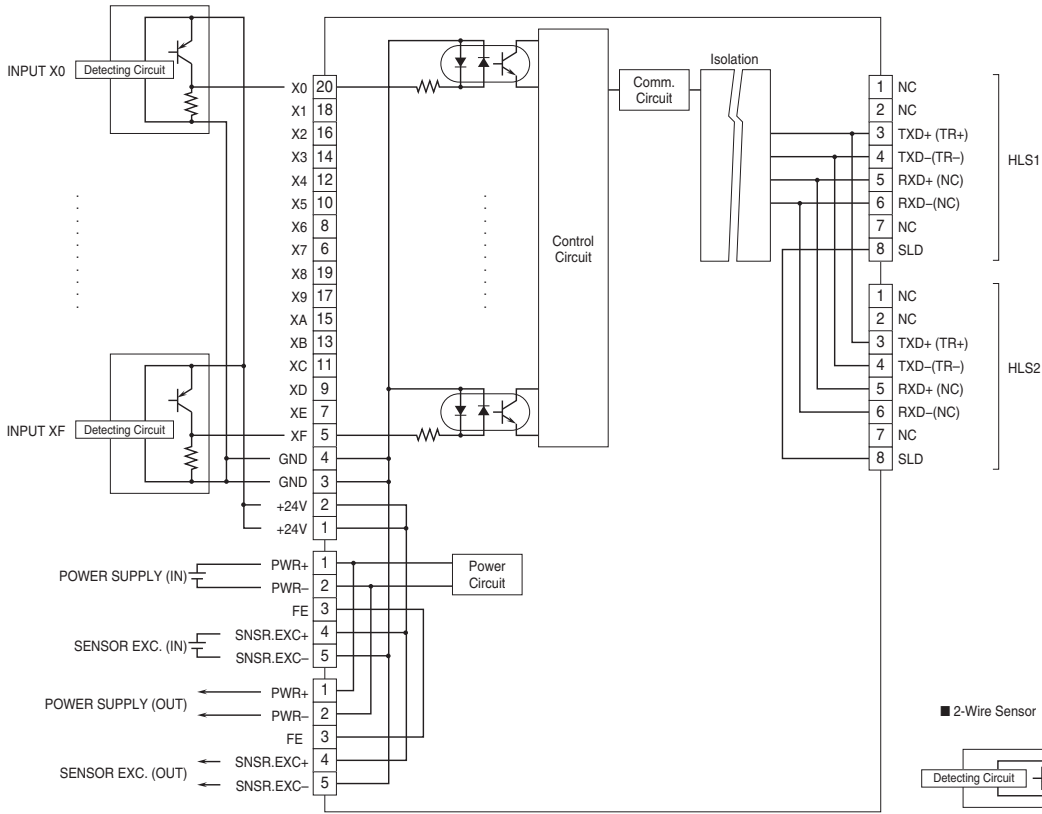

NPN TRANSISTOR OUTPUT MODULE, 16 points

(MIL connector)

MODEL:

R7F4DH-2-DC16A

R7F4DH-3-DC16A

SPECIFICATIONS

Common: Negative common (NPN) per 16 points

Number of I/O: Output, 16 points

Maximum outputs applicable at once: No limit (at 24 V DC)

I/O status indicator: LED turns on with closed contact.

Isolation: Output or sensor excitation to HLS to power input to FE

Data allocation: 1

Rated load voltage: 24 V AC $\pm 10\%$ (ripple 5 %p-p max.)

Rated output current: 0.1 A per point, 1.6 A per common

Residual voltage: ≤ 1.2 V

Leakage current: ≤ 0.1 mA

ON delay: ≤ 0.5 msec.

OFF delay: ≤ 0.5 msec.

Overload current protection function: Limits the current value when overcurrent is detected

Overheat Protection Function:

Turns OFF the output when overheat is detected

TERMINAL ASSIGNMENTS

■ Output Connection

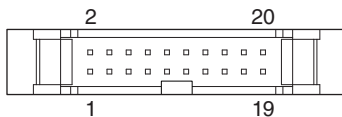

1. Terminal block code 2

PIN No	ID	FUNCTION	PIN No	ID	FUNCTION
1	Y0	Output 0	11	YA	Output 10
2	Y1	Output 1	12	YB	Output 11
3	Y2	Output 2	13	YC	Output 12
4	Y3	Output 3	14	YD	Output 13
5	Y4	Output 4	15	YE	Output 14
6	Y5	Output 5	16	YF	Output 15
7	Y6	Output 6	17	GND	0V
8	Y7	Output 7	18	GND	0V
9	Y8	Output 8	19	+24V	24VDC
10	Y9	Output 9	20	+24V	24VDC

2. Terminal block code 3

PIN No	ID	FUNCTION	PIN No	ID	FUNCTION
1	+24V	24VDC	11	YC	Output 12
2	+24V	24VDC	12	Y4	Output 4
3	GND	0V	13	YB	Output 11
4	GND	0V	14	Y3	Output 3
5	YF	Output 15	15	YA	Output 10
6	Y7	Output 7	16	Y2	Output 2
7	YE	Output 14	17	Y9	Output 9
8	Y6	Output 6	18	Y1	Output 1
9	YD	Output 13	19	Y8	Output 8
10	Y5	Output 5	20	Y0	Output 0

SCHEMATIC CIRCUITRY

Note: In order to improve EMC performance, bond the FE terminal to ground.

Caution: FE terminal is NOT a protective conductor terminal.

■ TERMINAL CODE 2

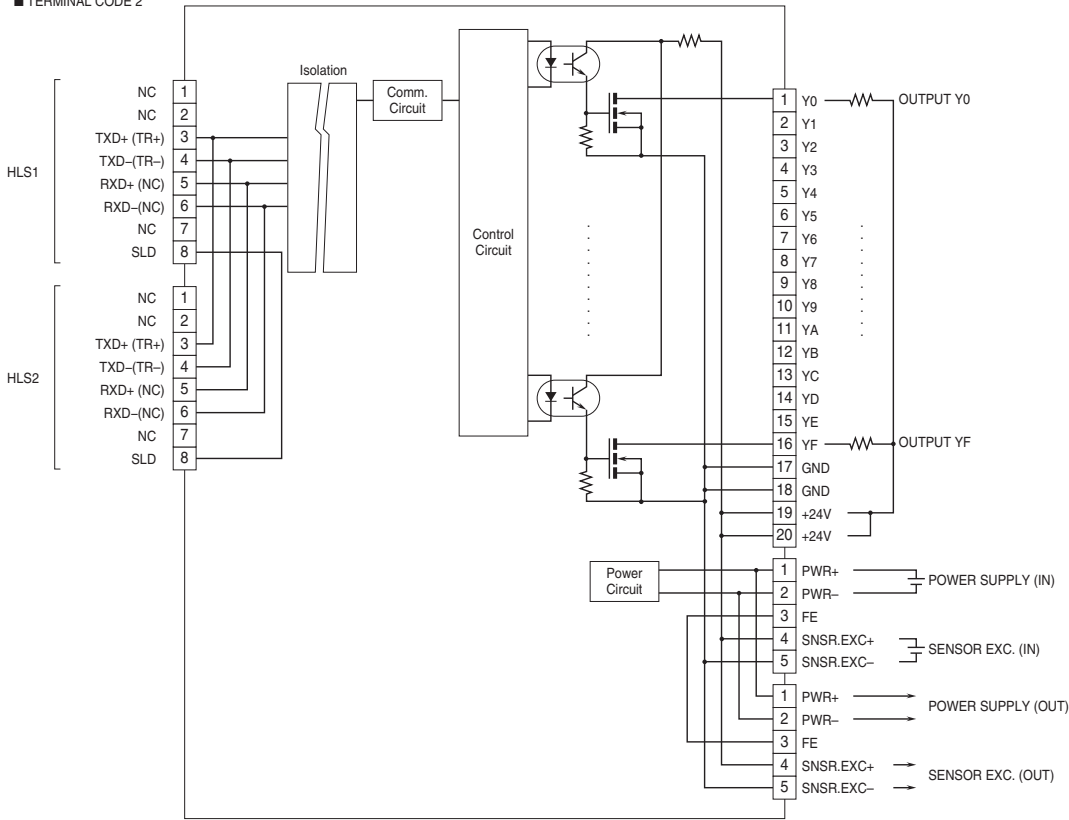

■ TERMINAL CODE 3

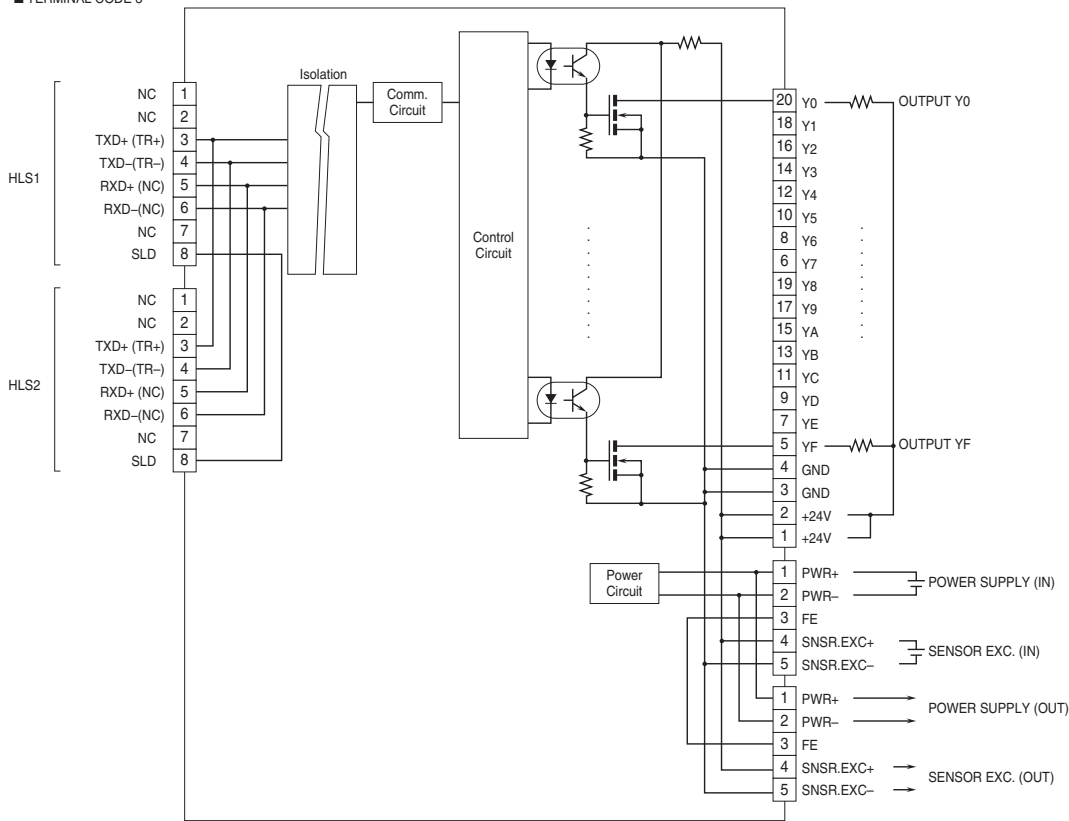

PNP TRANSISTOR OUTPUT MODULE, 16 points

(MIL connector)

MODEL:

R7F4DH-2-DC16B

R7F4DH-3-DC16B

SPECIFICATIONS

Common: Positive common (PNP) per 16 points

Number of I/O: Output, 16 points

Maximum outputs applicable at once: No limit (at 24 V DC)

I/O status indicator: LED turns on with closed contact.

Isolation: Output or sensor excitation to HLS to power input to FE

Data allocation: 1

Rated load voltage: 24 V AC $\pm 10\%$ (ripple 5 %p-p max.)

Rated output current: 0.1 A per point, 1.6 A per common

Residual voltage: ≤ 1.2 V

Leakage current: ≤ 0.1 mA

ON delay: ≤ 0.5 msec.

OFF delay: ≤ 0.5 msec.

Overload current protection function: Limits the current value when overcurrent is detected

Overheat Protection Function:

Turns OFF the output when overheat is detected

TERMINAL ASSIGNMENTS

■ Output Connection

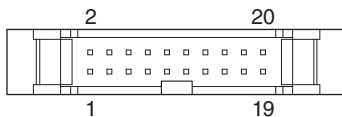

1. Terminal block code 2

PIN No	ID	FUNCTION	PIN No	ID	FUNCTION
1	Y0	Output 0	11	YA	Output 10
2	Y1	Output 1	12	YB	Output 11
3	Y2	Output 2	13	YC	Output 12
4	Y3	Output 3	14	YD	Output 13
5	Y4	Output 4	15	YE	Output 14
6	Y5	Output 5	16	YF	Output 15
7	Y6	Output 6	17	GND	0V
8	Y7	Output 7	18	GND	0V
9	Y8	Output 8	19	+24V	24VDC
10	Y9	Output 9	20	+24V	24VDC

2. Terminal block code 3

PIN No	ID	FUNCTION	PIN No	ID	FUNCTION
1	+24V	24VDC	11	YC	Output 12
2	+24V	24VDC	12	Y4	Output 4
3	GND	0V	13	YB	Output 11
4	GND	0V	14	Y3	Output 3
5	YF	Output 15	15	YA	Output 10
6	Y7	Output 7	16	Y2	Output 2
7	YE	Output 14	17	Y9	Output 9
8	Y6	Output 6	18	Y1	Output 1
9	YD	Output 13	19	Y8	Output 8
10	Y5	Output 5	20	Y0	Output 0

SCHEMATIC CIRCUITRY

Note: In order to improve EMC performance, bond the FE terminal to ground.

Caution: FE terminal is NOT a protective conductor terminal.

■ TERMINAL CODE 2

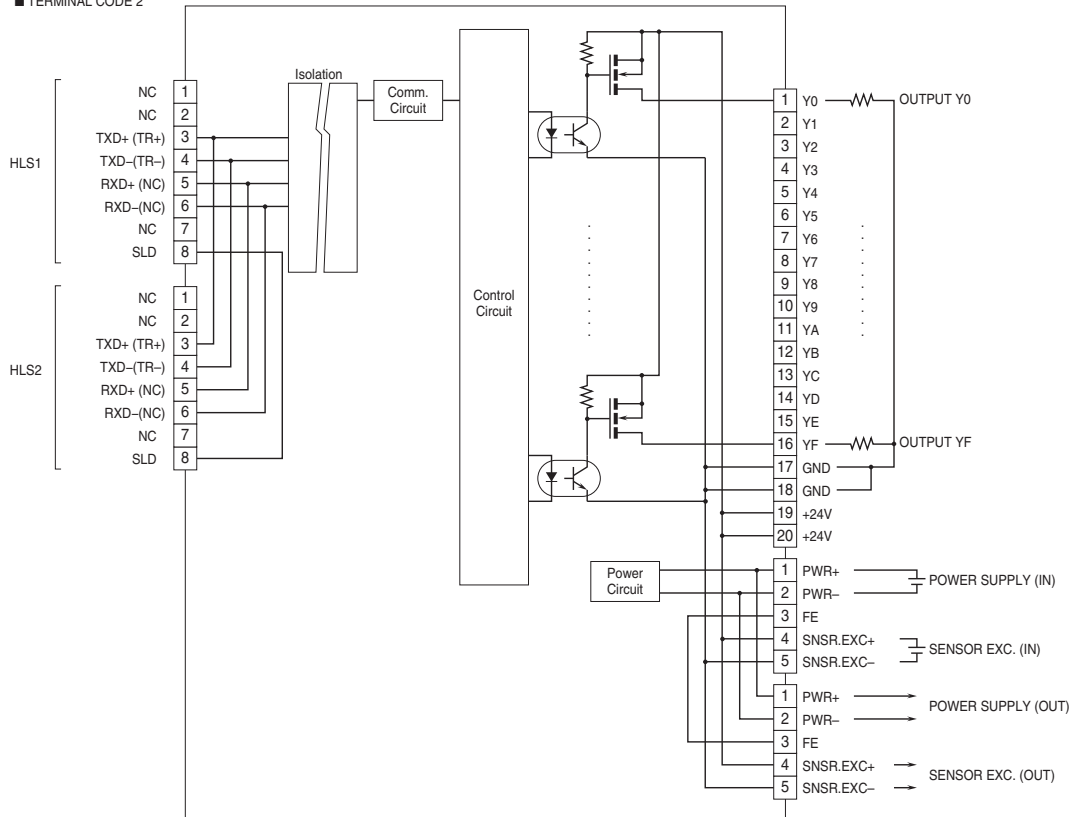

■ TERMINAL CODE 3

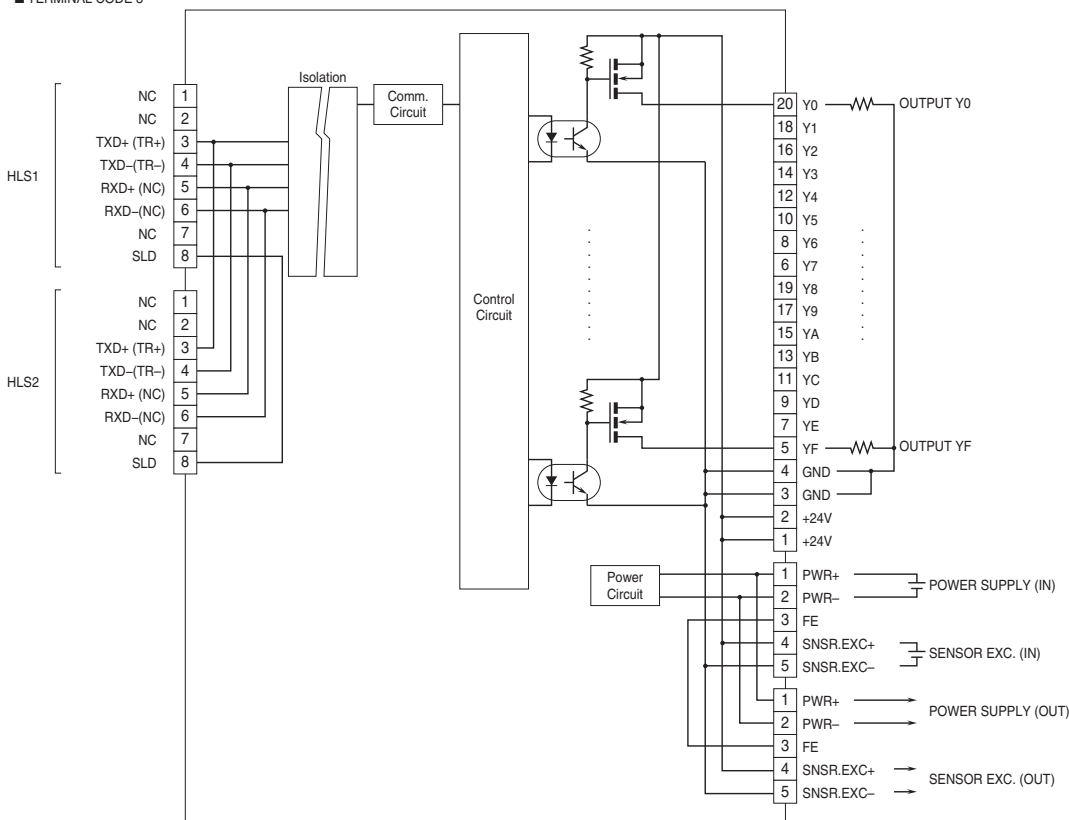

PNP DISCRETE INPUT &

NPN TRANSISTOR OUTPUT MODULE, 8 points each

(MIL connector)

MODEL:

R7F4DH-2-DAC16A

R7F4DH-3-DAC16A

SPECIFICATIONS

COMMON SPECIFICATIONS

Common: Negative common per 16 points

Input rating/load voltage: 24 V DC $\pm 10\%$, ripple 5 %p-p max.

Number of I/O: Input, 8 points; Output, 8 points

Maximum I/O applicable at once: No limit (at 24 V DC)

I/O status indicator: LED turns on with closed contact.

Isolation: I/O or sensor excitation to HLS to power input to FE

Data allocation: 1

INPUT

ON voltage / current: ≥ 15 V DC (I/O's X0 through X7 to 0 V) / ≥ 3.5 mA

OFF voltage / current: ≤ 5 V DC (I/O's X0 through X7 to 0 V) / ≤ 1 mA

Input current: ≤ 5.5 mA per point at 24 V DC

Input resistance: Approx. 4.4 k Ω

ON delay: ≤ 0.5 msec.

OFF delay: ≤ 0.5 msec.

OUTPUT

Rated output current: 0.1 A per point, 0.8 A per common

Residual voltage: ≤ 1.2 V

Leakage current: ≤ 0.1 mA

ON delay: ≤ 0.5 msec.

OFF delay: ≤ 0.5 msec.

Overload current protection function: Limits the current value when overcurrent is detected

Overheat Protection Function:

Turns OFF the output when overheat is detected

TERMINAL ASSIGNMENTS

I/O Connection

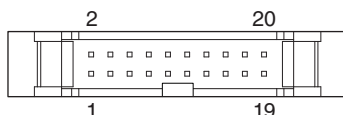

1. Terminal block code 2

PIN No	ID	FUNCTION	PIN No	ID	FUNCTION
1	X0	Input 0	11	Y2	Output 2
2	X1	Input 1	12	Y3	Output 3
3	X2	Input 2	13	Y4	Output 4
4	X3	Input 3	14	Y5	Output 5
5	X4	Input 4	15	Y6	Output 6
6	X5	Input 5	16	Y7	Output 7
7	X6	Input 6	17	GND	0V
8	X7	Input 7	18	GND	0V
9	Y0	Output 0	19	+24V	24VDC
10	Y1	Output 1	20	+24V	24VDC

2. Terminal block code 3

PIN No	ID	FUNCTION	PIN No	ID	FUNCTION
1	+24V	24VDC	11	Y4	Output 4
2	+24V	24VDC	12	X4	Input 4
3	GND	0V	13	Y3	Output 3
4	GND	0V	14	X3	Input 3
5	Y7	Output 7	15	Y2	Output 2
6	X7	Input 7	16	X2	Input 2
7	Y6	Output 6	17	Y1	Output 1
8	X6	Input 6	18	X1	Input 1
9	Y5	Output 5	19	Y0	Output 0
10	X5	Input 5	20	X0	Input 0



SCHEMATIC CIRCUITRY

Note: In order to improve EMC performance, bond the FE terminal to ground.

Caution: FE terminal is NOT a protective conductor terminal.

■ TERMINAL CODE 2

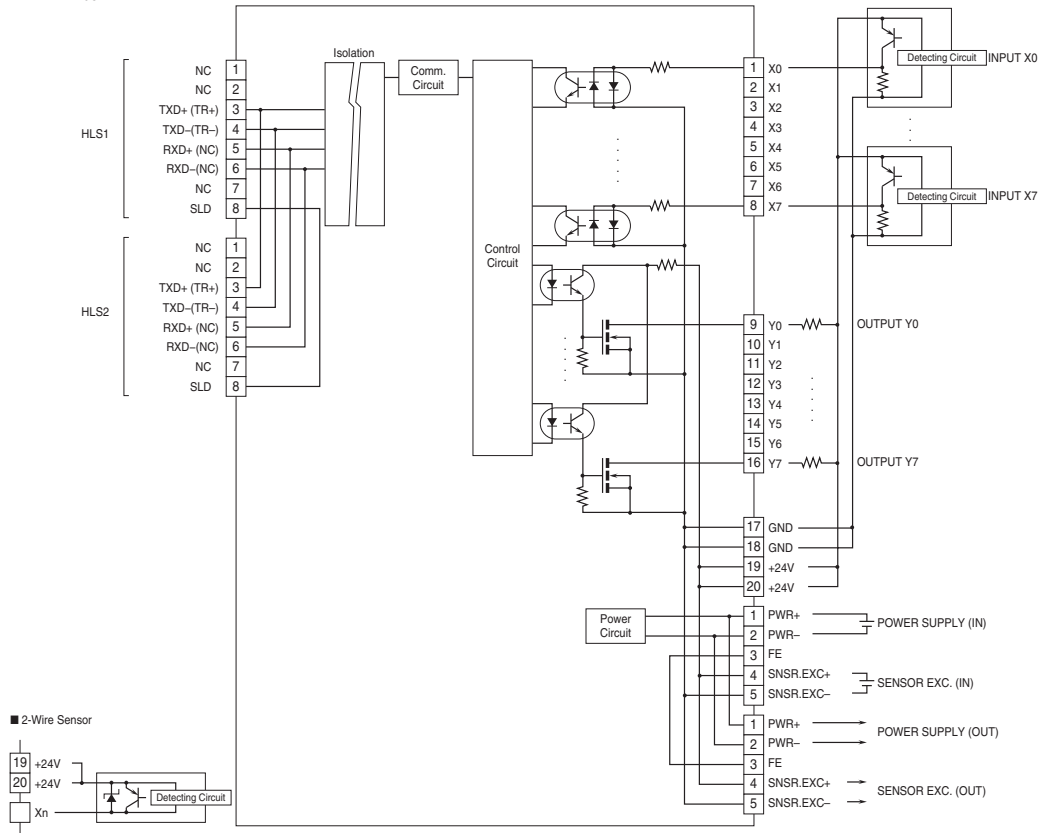

■ TERMINAL CODE 3

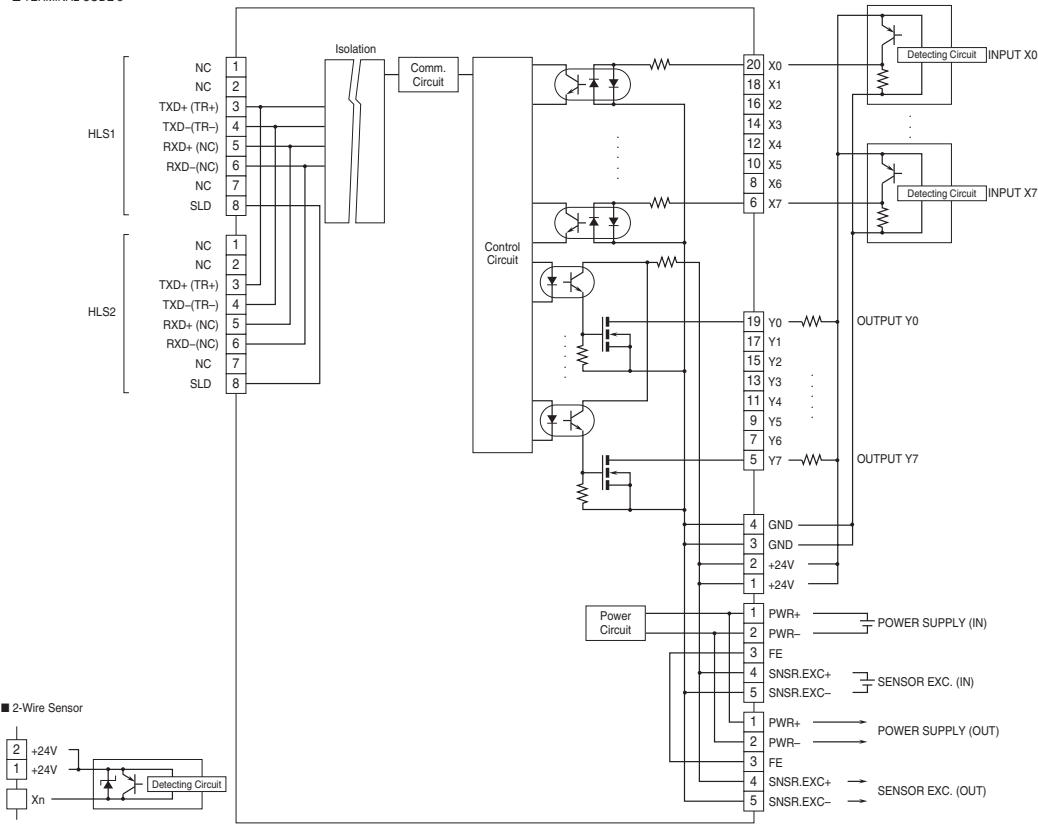

NPN DISCRETE INPUT &

PNP TRANSISTOR OUTPUT MODULE, 8 points each

(MIL connector)

MODEL:

R7F4DH-2-DAC16B

R7F4DH-3-DAC16B

SPECIFICATIONS

COMMON SPECIFICATIONS

Common: Positive common per 16 points

Input rating/load voltage: 24 V DC $\pm 10\%$, ripple 5 %p-p max.

Number of I/O: Input, 8 points; Output, 8 points

Maximum I/O applicable at once: No limit (at 24 V DC)

I/O status indicator: LED turns on with closed contact.

Isolation: I/O or sensor excitation to HLS to power input to FE

Data allocation: 1

INPUT

ON voltage / current: ≥ 15 V DC (I/O's X0 through X7 to +24 V) / ≥ 3.5 mA

OFF voltage / current: ≤ 5 V DC (I/O's X0 through X7 to +24 V) / ≤ 1 mA

Input current: ≤ 5.5 mA per point at 24 V DC

Input resistance: Approx. 4.4 k Ω

ON delay: ≤ 0.5 msec.

OFF delay: ≤ 0.5 msec.

OUTPUT

Rated output current: 0.1 A per point, 0.8 A per common

Residual voltage: ≤ 1.2 V

Leakage current: ≤ 0.1 mA

ON delay: ≤ 0.5 msec.

OFF delay: ≤ 0.5 msec.

Overload current protection function: Limits the current value when overcurrent is detected

Overheat Protection Function:

Turns OFF the output when overheat is detected

TERMINAL ASSIGNMENTS

I/O Connection

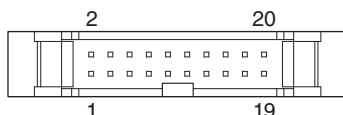

1. Terminal block code 2

PIN No	ID	FUNCTION	PIN No	ID	FUNCTION
1	X0	Input 0	11	Y2	Output 2
2	X1	Input 1	12	Y3	Output 3
3	X2	Input 2	13	Y4	Output 4
4	X3	Input 3	14	Y5	Output 5
5	X4	Input 4	15	Y6	Output 6
6	X5	Input 5	16	Y7	Output 7
7	X6	Input 6	17	GND	0V
8	X7	Input 7	18	GND	0V
9	Y0	Output 0	19	+24V	24VDC
10	Y1	Output 1	20	+24V	24VDC

2. Terminal block code 3

PIN No	ID	FUNCTION	PIN No	ID	FUNCTION
1	+24V	24VDC	11	Y4	Output 4
2	+24V	24VDC	12	X4	Input 4
3	GND	0V	13	Y3	Output 3
4	GND	0V	14	X3	Input 3
5	Y7	Output 7	15	Y2	Output 2
6	X7	Input 7	16	X2	Input 2
7	Y6	Output 6	17	Y1	Output 1
8	X6	Input 6	18	X1	Input 1
9	Y5	Output 5	19	Y0	Output 0
10	X5	Input 5	20	X0	Input 0



SCHEMATIC CIRCUITRY

Note: In order to improve EMC performance, bond the FE terminal to ground.

Caution: FE terminal is NOT a protective conductor terminal.

■ TERMINAL CODE 2

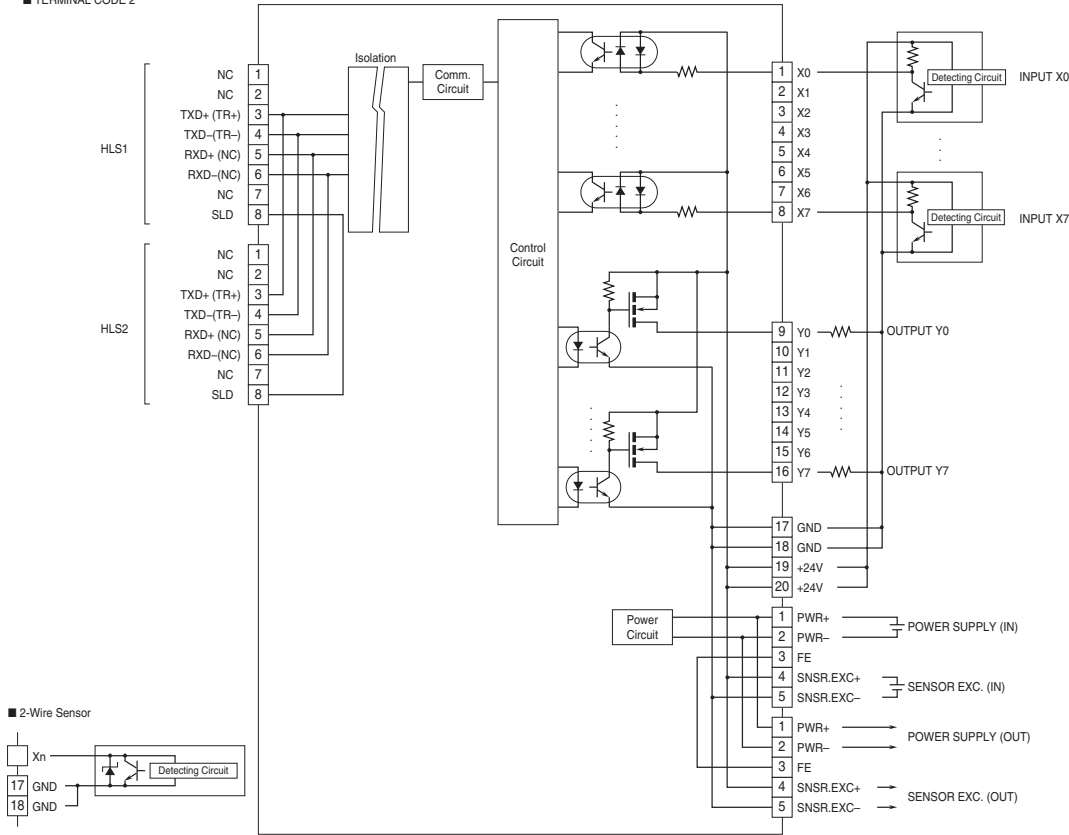

■ TERMINAL CODE 3

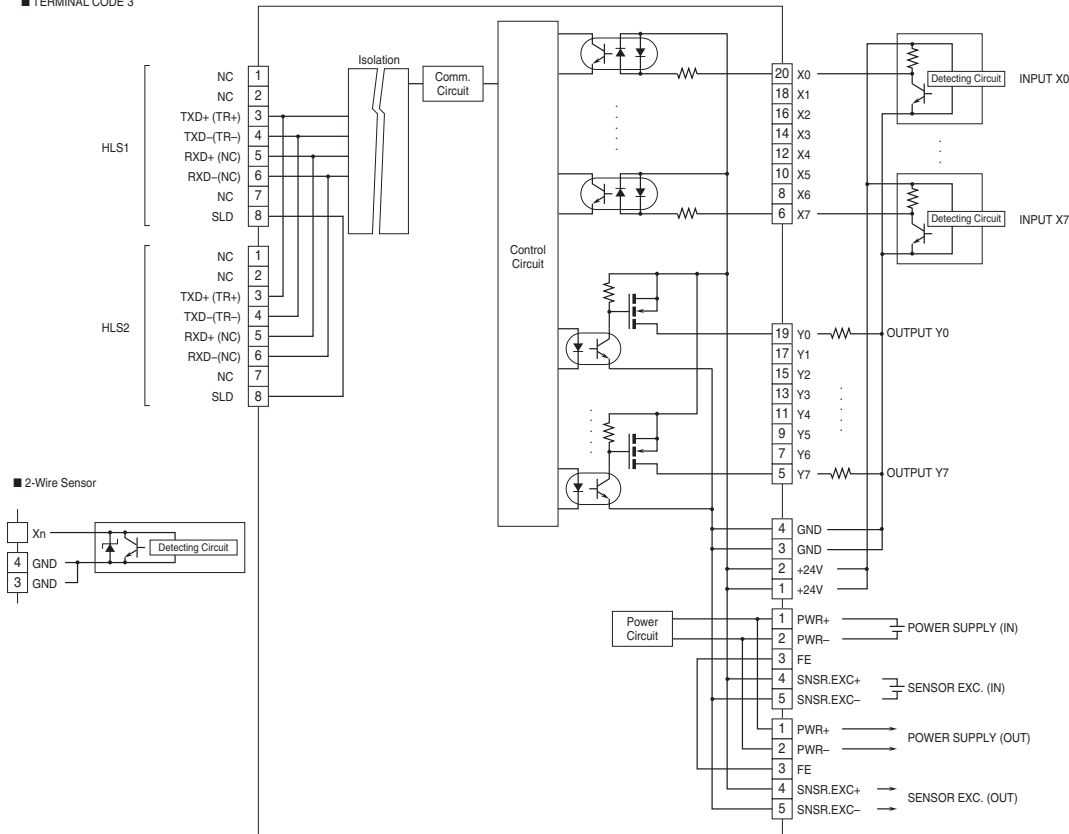

NPN DISCRETE INPUT &

NPN TRANSISTOR OUTPUT MODULE, 8 points each

(MIL connector)

MODEL:

R7F4DH-2-DAC16C

R7F4DH-3-DAC16C

SPECIFICATIONS

COMMON SPECIFICATIONS

Input common: Positive common per 8 points

Output common: Negative common per 8 points

Input rating/load voltage: 24 V DC $\pm 10\%$, ripple 5 %p-p max.

Number of I/O: Input, 8 points; Output, 8 points

Maximum I/O applicable at once: No limit (at 24 V DC)

I/O status indicator: LED turns on with closed contact.

Isolation: I/O or sensor excitation to HLS to power input to FE

Data allocation: 1

INPUT

ON voltage / current: ≥ 15 V DC (I/O's X0 through X7 to +24 V) / ≥ 3.5 mA

OFF voltage / current: ≤ 5 V DC (I/O's X0 through X7 to +24 V) / ≤ 1 mA

Input current: ≤ 5.5 mA per point at 24 V DC

Input resistance: Approx. 4.4 k Ω

ON delay: ≤ 0.5 msec.

OFF delay: ≤ 0.5 msec.

OUTPUT

Rated output current: 0.1 A per point, 0.8 A per common

Residual voltage: ≤ 1.2 V

Leakage current: ≤ 0.1 mA

ON delay: ≤ 0.5 msec.

OFF delay: ≤ 0.5 msec.

Overload current protection function: Limits the current value when overcurrent is detected

Overheat Protection Function:

Turns OFF the output when overheat is detected

TERMINAL ASSIGNMENTS

I/O Connection

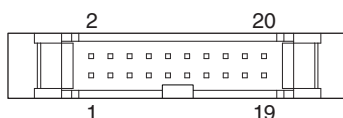

1. Terminal block code 2

PIN No	ID	FUNCTION	PIN No	ID	FUNCTION
1	X0	Input 0	11	Y2	Output 2
2	X1	Input 1	12	Y3	Output 3
3	X2	Input 2	13	Y4	Output 4
4	X3	Input 3	14	Y5	Output 5
5	X4	Input 4	15	Y6	Output 6
6	X5	Input 5	16	Y7	Output 7
7	X6	Input 6	17	GND	0V
8	X7	Input 7	18	GND	0V
9	Y0	Output 0	19	+24V	24VDC
10	Y1	Output 1	20	+24V	24VDC

2. Terminal block code 3

PIN No	ID	FUNCTION	PIN No	ID	FUNCTION
1	+24V	24VDC	11	Y4	Output 4
2	+24V	24VDC	12	X4	Input 4
3	GND	0V	13	Y3	Output 3
4	GND	0V	14	X3	Input 3
5	Y7	Output 7	15	Y2	Output 2
6	X7	Input 7	16	X2	Input 2
7	Y6	Output 6	17	Y1	Output 1
8	X6	Input 6	18	X1	Input 1
9	Y5	Output 5	19	Y0	Output 0
10	X5	Input 5	20	X0	Input 0

SCHEMATIC CIRCUITRY

Note: In order to improve EMC performance, bond the FE terminal to ground.

Caution: FE terminal is NOT a protective conductor terminal.

■ TERMINAL CODE 2

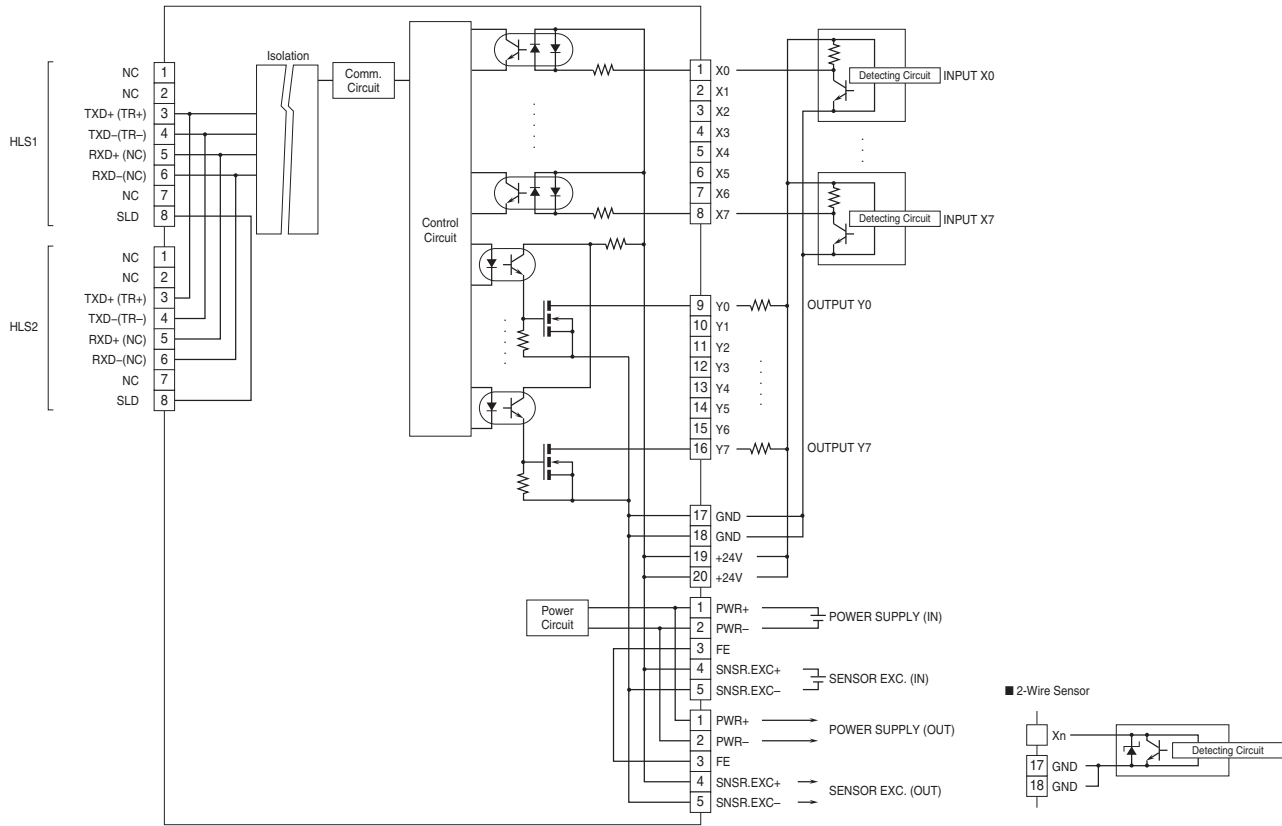

■ TERMINAL CODE 3

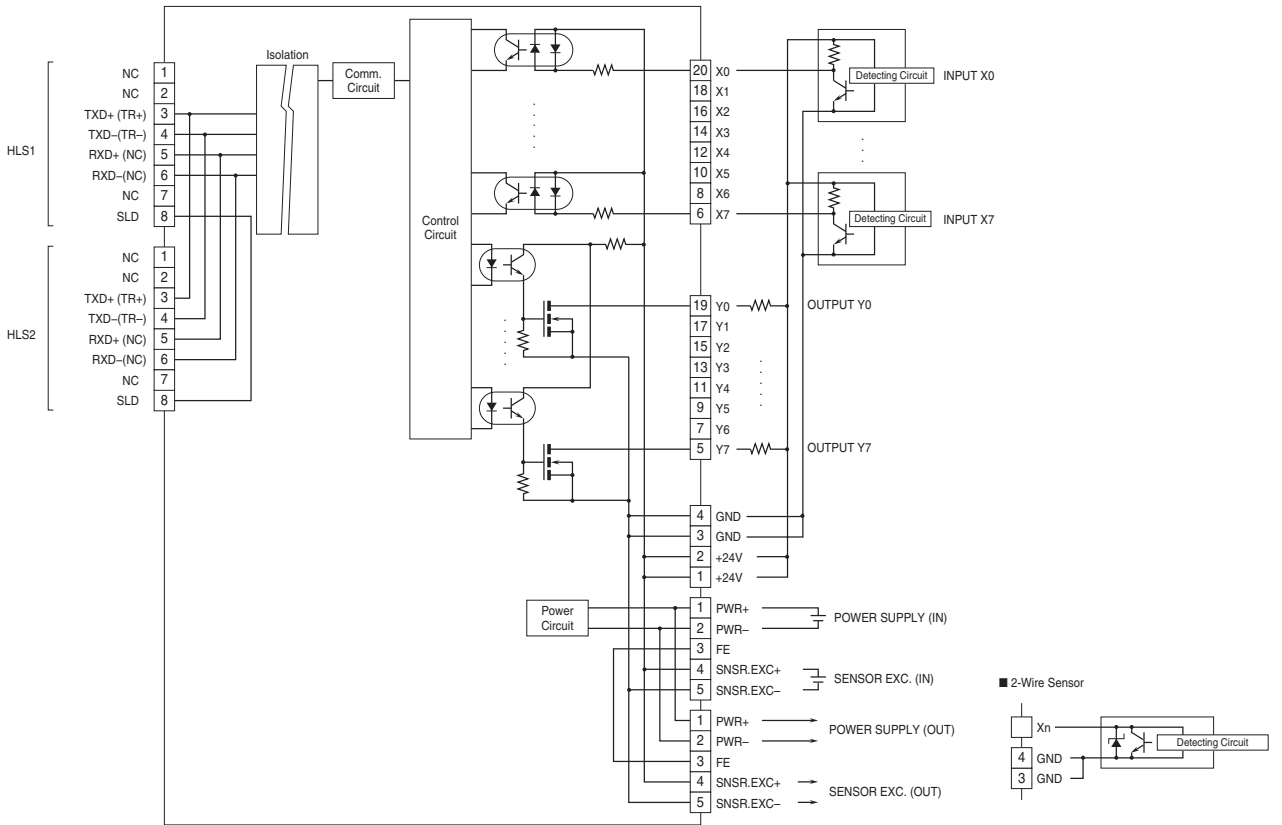

PNP DISCRETE INPUT &

PNP TRANSISTOR OUTPUT MODULE, 8 points each

(MIL connector)

MODEL:

R7F4DH-2-DAC16D

R7F4DH-3-DAC16D

SPECIFICATIONS

COMMON SPECIFICATIONS

Input common: Negative common per 8 points

Output common: Positive common per 8 points

Input rating/load voltage: 24 V DC $\pm 10\%$, ripple 5 %p-p max.

Number of I/O: Input, 8 points; Output, 8 points

Maximum I/O applicable at once: No limit (at 24 V DC)

I/O status indicator: LED turns on with closed contact.

Isolation: I/O or sensor excitation to HLS to power input to FE

Data allocation: 1

INPUT

ON voltage / current: ≥ 15 V DC (I/O's X0 through X7 to 0 V) / ≥ 3.5 mA

OFF voltage / current: ≤ 5 V DC (I/O's X0 through X7 to 0 V) / ≤ 1 mA

Input current: ≤ 5.5 mA per point at 24 V DC

Input resistance: Approx. 4.4 k Ω

ON delay: ≤ 0.5 msec.

OFF delay: ≤ 0.5 msec.

OUTPUT

Rated output current: 0.1 A per point, 0.8 A per common

Residual voltage: ≤ 1.2 V

Leakage current: ≤ 0.1 mA

ON delay: ≤ 0.5 msec.

OFF delay: ≤ 0.5 msec.

Overload current protection function: Limits the current value when overcurrent is detected

Overheat Protection Function:

Turns OFF the output when overheat is detected

TERMINAL ASSIGNMENTS

I/O Connection

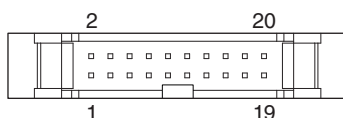

1. Terminal block code 2

PIN No	ID	FUNCTION	PIN No	ID	FUNCTION
1	X0	Input 0	11	Y2	Output 2
2	X1	Input 1	12	Y3	Output 3
3	X2	Input 2	13	Y4	Output 4
4	X3	Input 3	14	Y5	Output 5
5	X4	Input 4	15	Y6	Output 6
6	X5	Input 5	16	Y7	Output 7
7	X6	Input 6	17	GND	0V
8	X7	Input 7	18	GND	0V
9	Y0	Output 0	19	+24V	24VDC
10	Y1	Output 1	20	+24V	24VDC

2. Terminal block code 3

PIN No	ID	FUNCTION	PIN No	ID	FUNCTION
1	+24V	24VDC	11	Y4	Output 4
2	+24V	24VDC	12	X4	Input 4
3	GND	0V	13	Y3	Output 3
4	GND	0V	14	X3	Input 3
5	Y7	Output 7	15	Y2	Output 2
6	X7	Input 7	16	X2	Input 2
7	Y6	Output 6	17	Y1	Output 1
8	X6	Input 6	18	X1	Input 1
9	Y5	Output 5	19	Y0	Output 0
10	X5	Input 5	20	X0	Input 0

SCHEMATIC CIRCUITRY

Note: In order to improve EMC performance, bond the FE terminal to ground.

Caution: FE terminal is NOT a protective conductor terminal.

■ TERMINAL CODE 2

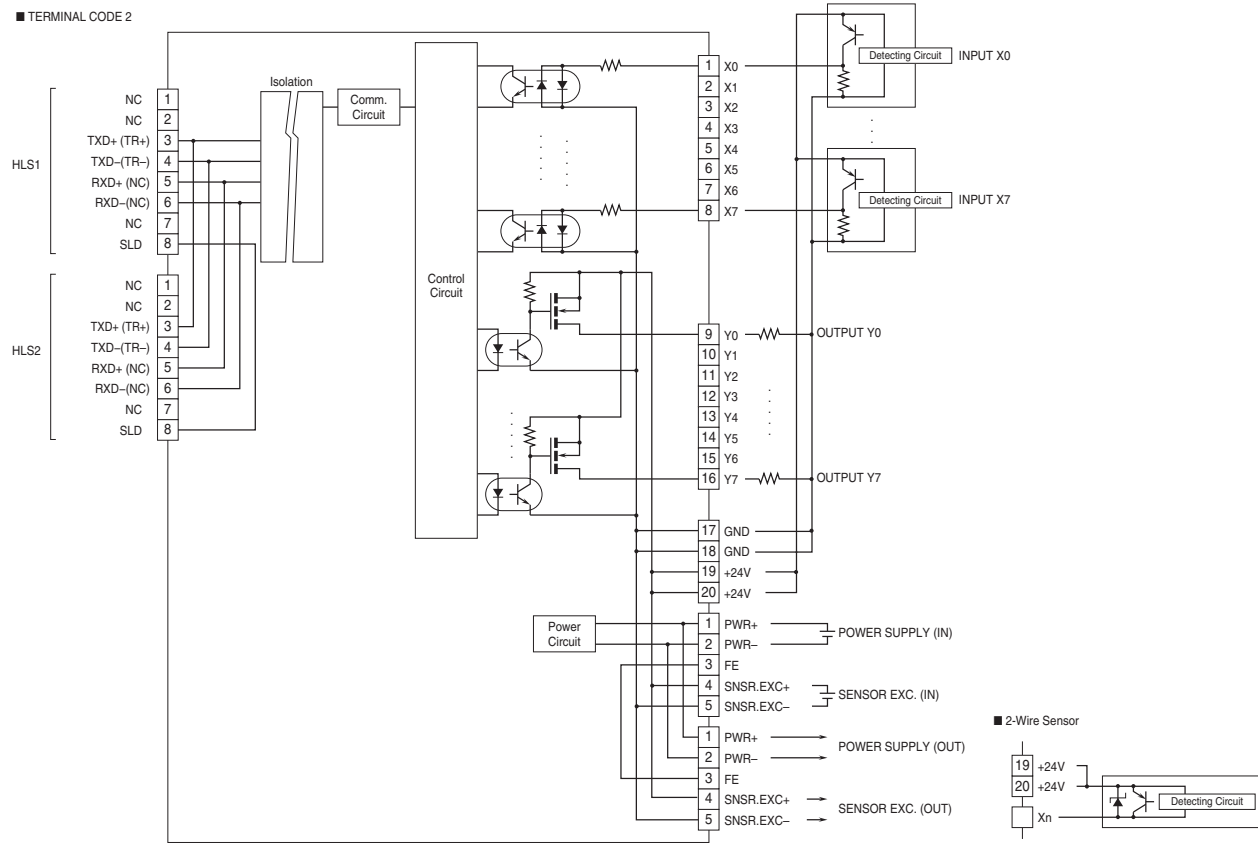

■ TERMINAL CODE 3

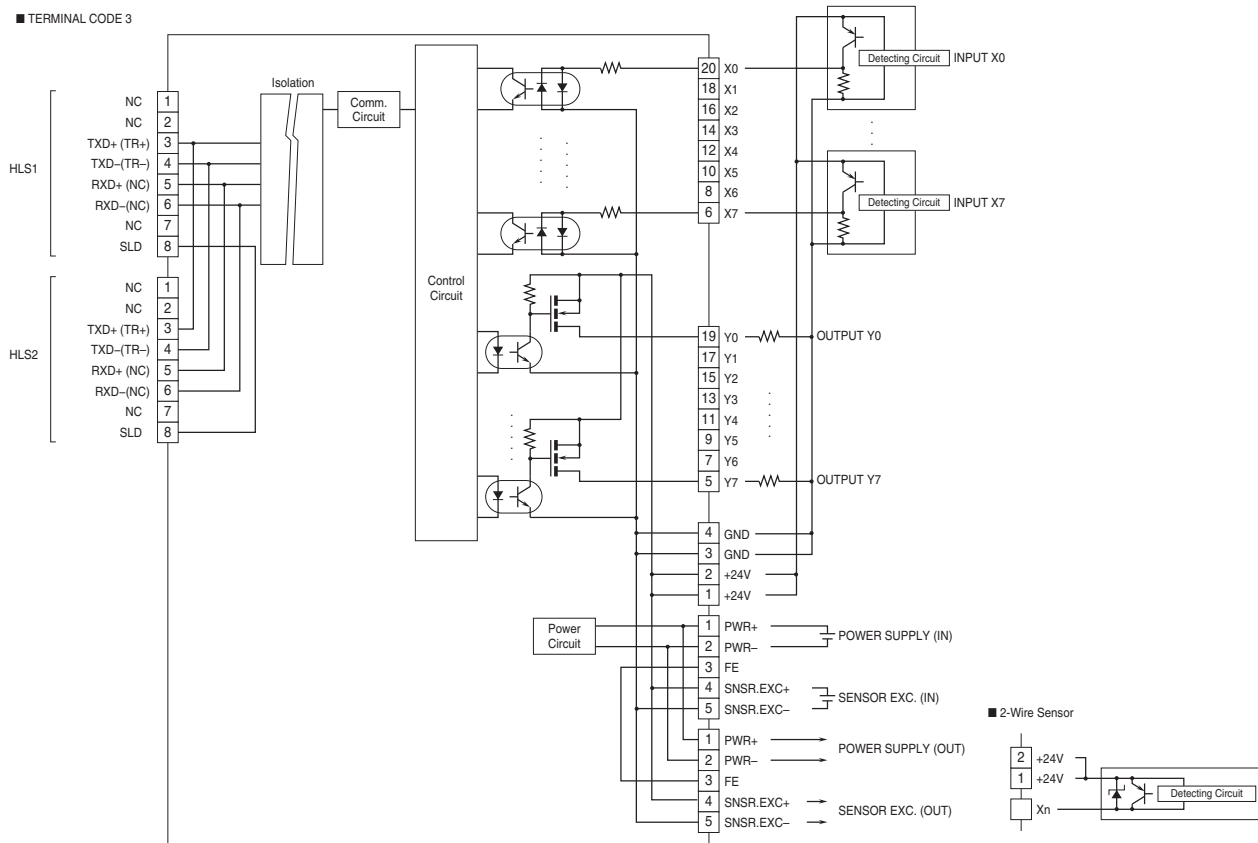

NPN DISCRETE INPUT MODULE, 16 points

(Tension clamp terminal block)

MODEL: R7F4DH-4-DA16A

SPECIFICATIONS

Common: Positive common (NPN) per 16 points

Number of I/O: Input, 16 points

Maximum inputs applicable at once: No limit (at 24 V DC)

I/O status indicator: LED turns on with closed contact.

Isolation: Input or sensor excitation to HLS to power input to FE

Data allocation: 1

Rated input voltage: 24 V DC $\pm 10\%$; ripple 5 %p-p max.

ON voltage / current: ≥ 15 V DC (input - +24V) / ≥ 3.5 mA

OFF voltage / current: ≤ 5 V DC (input - +24V) / ≤ 1 mA

Input current: ≤ 5.5 mA per point at 24 V DC

Input resistance: Approx. 4.4 k Ω

ON delay: ≤ 0.5 msec.

OFF delay: ≤ 0.5 msec.

TERMINAL ASSIGNMENTS

Input Connection

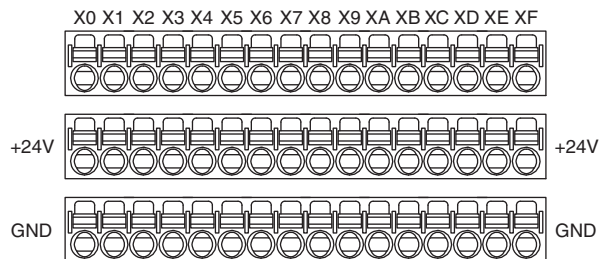

PIN No	ID	FUNCTION	PIN No	ID	FUNCTION
X0	1	X0 Input 0	X8	1	X8 Input 8
	2	+24V 24V DC		2	+24V 24V DC
	3	GND 0V		3	GND 0V
X1	1	X1 Input 1	X9	1	X9 Input 9
	2	+24V 24V DC		2	+24V 24V DC
	3	GND 0V		3	GND 0V
X2	1	X2 Input 2	XA	1	XA Input 10
	2	+24V 24V DC		2	+24V 24V DC
	3	GND 0V		3	GND 0V
X3	1	X3 Input 3	XB	1	XB Input 11
	2	+24V 24V DC		2	+24V 24V DC
	3	GND 0V		3	GND 0V
X4	1	X4 Input 4	XC	1	XC Input 12
	2	+24V 24V DC		2	+24V 24V DC
	3	GND 0V		3	GND 0V
X5	1	X5 Input 5	XD	1	XD Input 13
	2	+24V 24V DC		2	+24V 24V DC
	3	GND 0V		3	GND 0V
X6	1	X6 Input 6	XE	1	XE Input 14
	2	+24V 24V DC		2	+24V 24V DC
	3	GND 0V		3	GND 0V
X7	1	X7 Input 7	XF	1	XF Input 15
	2	+24V 24V DC		2	+24V 24V DC
	3	GND 0V		3	GND 0V

SCHEMATIC CIRCUITRY

Note: In order to improve EMC performance, bond the FE terminal to ground.

Caution: FE terminal is NOT a protective conductor terminal.

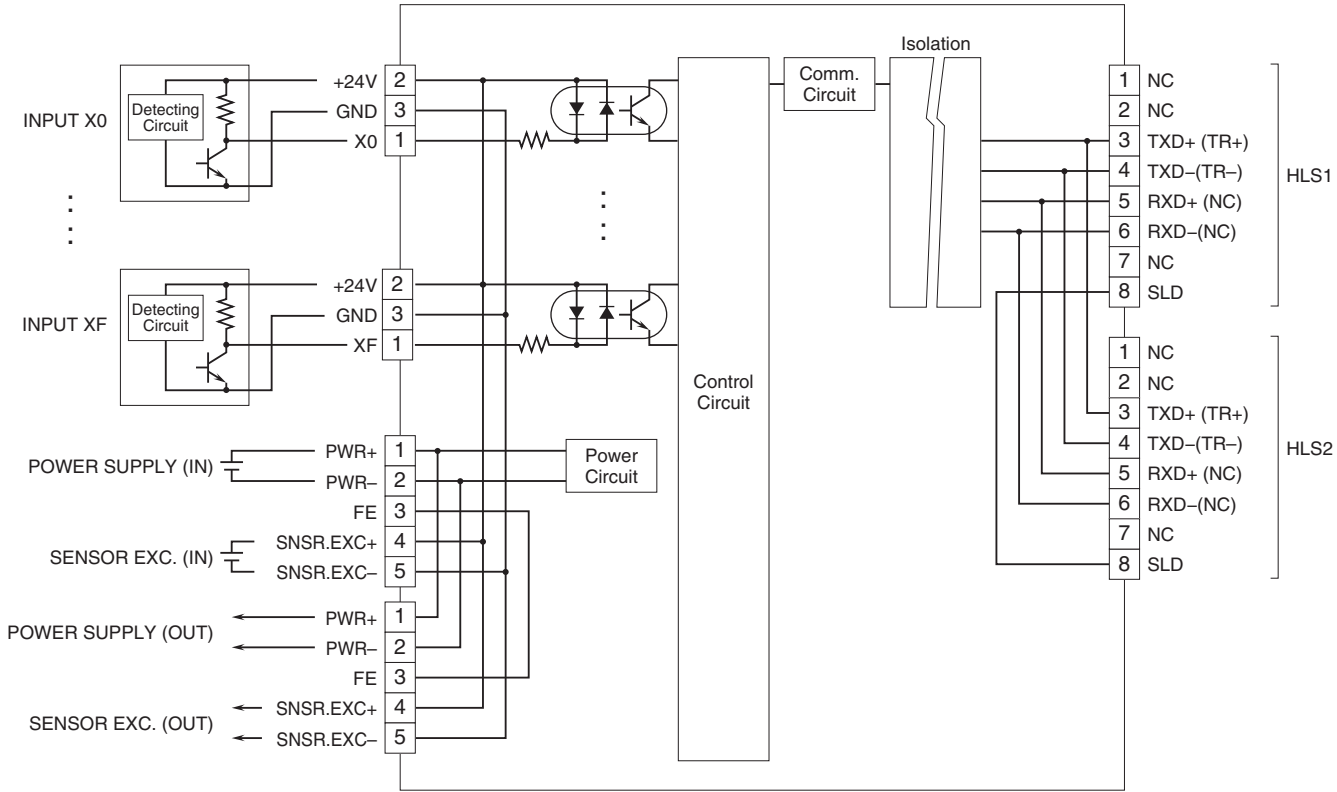

■ 2-Wire Sensor

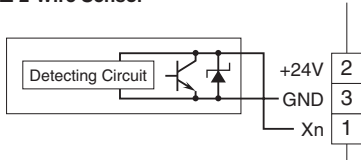

PNP DISCRETE INPUT MODULE, 16 points

(Tension clamp terminal block)

MODEL: R7F4DH-4-DA16B

SPECIFICATIONS

Common: Negative common (PNP) per 16 points

Number of I/O: Input, 16 points

Maximum inputs applicable at once: No limit (at 24 V DC)

I/O status indicator: LED turns on with closed contact.

Isolation: Input or sensor excitation to HLS to power input to FE

Data allocation: 1

Rated input voltage: 24 V DC $\pm 10\%$; ripple 5 %p-p max.

ON voltage / current: ≥ 15 V DC (input - 0V) / ≥ 3.5 mA

OFF voltage / current: ≤ 5 V DC (input - 0V) / ≤ 1 mA

Input current: ≤ 5.5 mA per point at 24 V DC

Input resistance: Approx. 4.4 k Ω

ON delay: ≤ 0.5 msec.

OFF delay: ≤ 0.5 msec.

TERMINAL ASSIGNMENTS

Input Connection

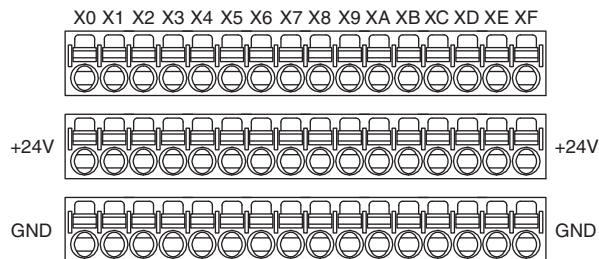

PIN No	ID	FUNCTION	PIN No	ID	FUNCTION
X0	1	X0	X8	1	X8
	2	+24V		2	+24V
	3	GND		3	GND
X1	1	X1	X9	1	X9
	2	+24V		2	+24V
	3	GND		3	GND
X2	1	X2	XA	1	XA
	2	+24V		2	+24V
	3	GND		3	GND
X3	1	X3	XB	1	XB
	2	+24V		2	+24V
	3	GND		3	GND
X4	1	X4	XC	1	XC
	2	+24V		2	+24V
	3	GND		3	GND
X5	1	X5	XD	1	XD
	2	+24V		2	+24V
	3	GND		3	GND
X6	1	X6	XE	1	XE
	2	+24V		2	+24V
	3	GND		3	GND
X7	1	X7	XF	1	XF
	2	+24V		2	+24V
	3	GND		3	GND

SCHEMATIC CIRCUITRY

Note: In order to improve EMC performance, bond the FE terminal to ground.
 Caution: FE terminal is NOT a protective conductor terminal.

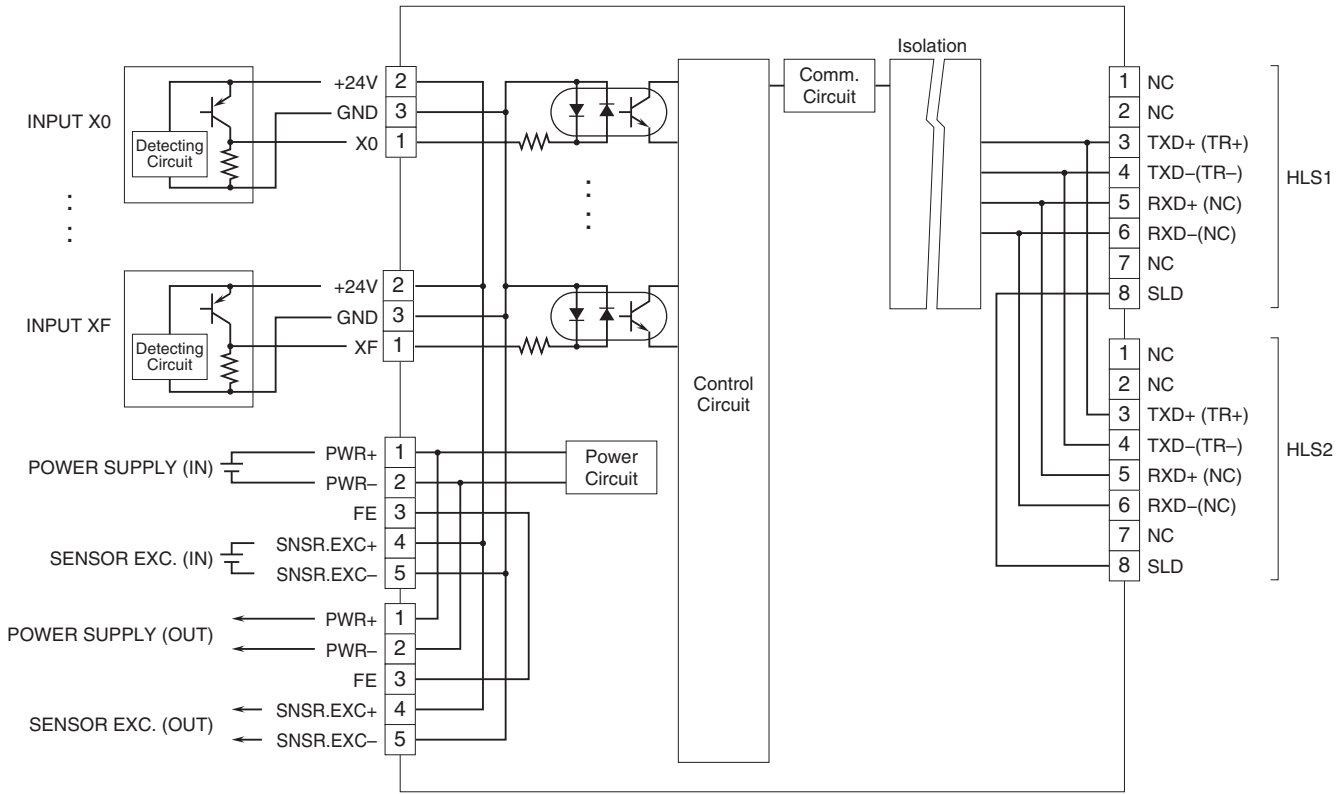

■ 2-Wire Sensor

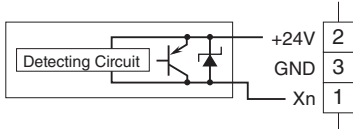

NPN TRANSISTOR OUTPUT MODULE, 16 points

(Tension clamp terminal block)

MODEL: R7F4DH-4-DC16A

SPECIFICATIONS

Common: Negative common (NPN) per 16 points

Number of I/O: Output, 16 points

Maximum outputs applicable at once: No limit (at 24 V DC)

I/O status indicator: LED turns on with closed contact.

Isolation: Output or sensor excitation to HLS to power input to FE

Data allocation: 1

Rated load voltage: 24 V AC $\pm 10\%$ (ripple 5 %p-p max.)

Rated output current: 0.1 A per point, 1.6 A per common

Residual voltage: ≤ 1.2 V

Leakage current: ≤ 0.1 mA

ON delay: ≤ 0.5 msec.

OFF delay: ≤ 0.5 msec.

Overload current protection function: Limits the current value when overcurrent is detected

Overheat Protection Function:

Turns OFF the output when overheat is detected

TERMINAL ASSIGNMENTS

■ Output Connection

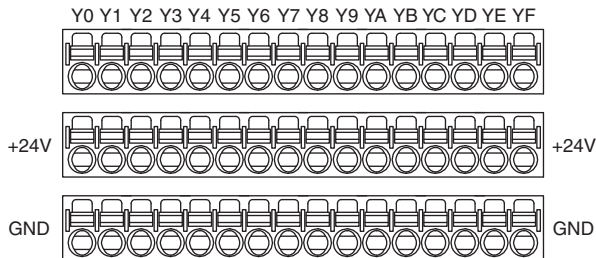

PIN No	ID	FUNCTION	PIN No	ID	FUNCTION
Y0	1	Y0	Y8	1	Y8
	2	+24V		2	+24V
	3	GND		3	GND
Y1	1	Y1	Y9	1	Y9
	2	+24V		2	+24V
	3	GND		3	GND
Y2	1	Y2	YA	1	YA
	2	+24V		2	+24V
	3	GND		3	GND
Y3	1	Y3	YB	1	YB
	2	+24V		2	+24V
	3	GND		3	GND
Y4	1	Y4	YC	1	YC
	2	+24V		2	+24V
	3	GND		3	GND
Y5	1	Y5	YD	1	YD
	2	+24V		2	+24V
	3	GND		3	GND
Y6	1	Y6	YE	1	YE
	2	+24V		2	+24V
	3	GND		3	GND
Y7	1	Y7	YF	1	YF
	2	+24V		2	+24V
	3	GND		3	GND

SCHEMATIC CIRCUITRY

Note: In order to improve EMC performance, bond the FE terminal to ground.

Caution: FE terminal is NOT a protective conductor terminal.

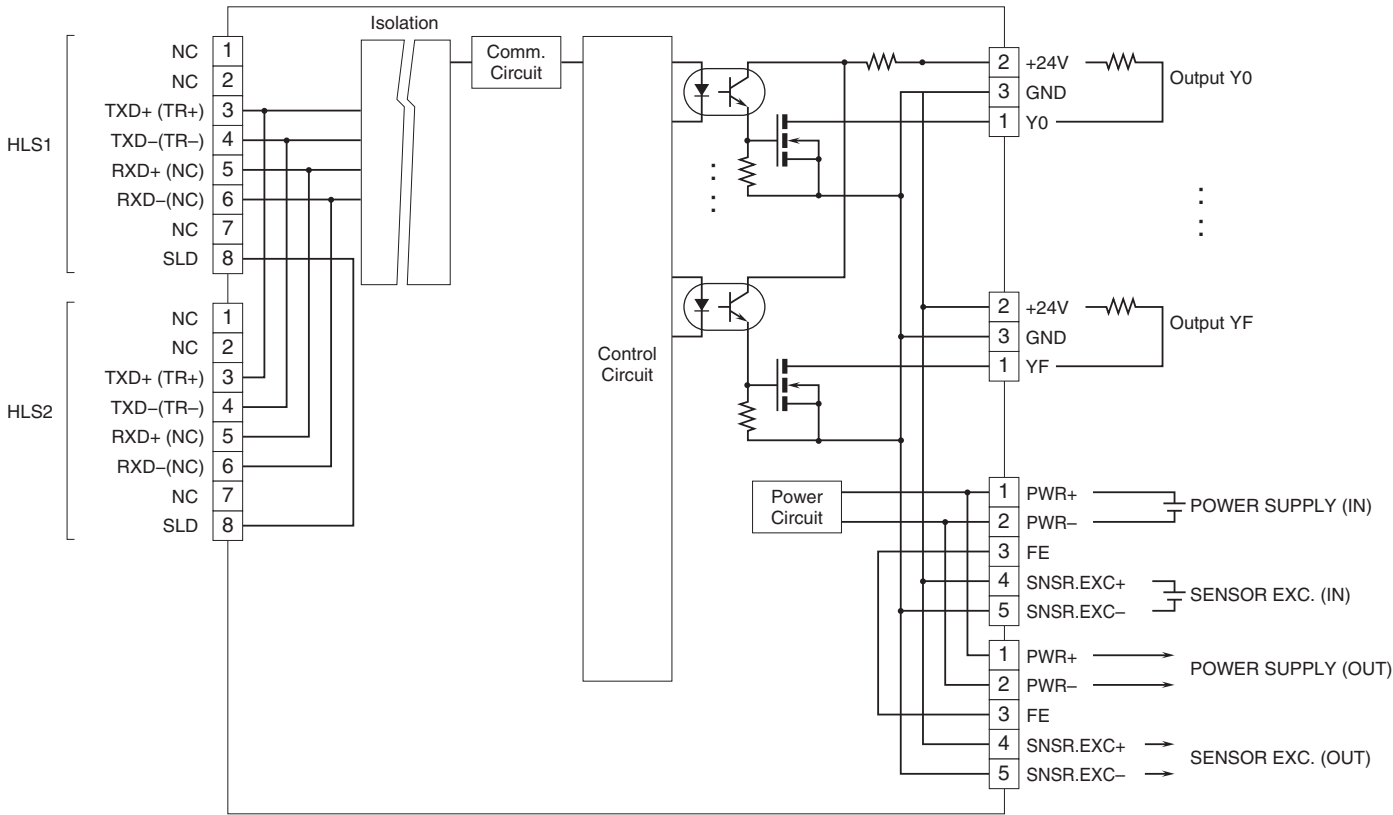

PNP TRANSISTOR OUTPUT MODULE, 16 points

(Tension clamp terminal block)

MODEL: R7F4DH-4-DC16B

SPECIFICATIONS

Common: Positive common (PNP) per 16 points

Number of I/O: Output, 16 points

Maximum outputs applicable at once: No limit (at 24 V DC)

I/O status indicator: LED turns on with closed contact.

Isolation: Output or sensor excitation to HLS to power input to FE

Data allocation: 1

Rated load voltage: 24 V AC $\pm 10\%$ (ripple 5 %p-p max.)

Rated output current: 0.1 A per point, 1.6 A per common

Residual voltage: ≤ 1.2 V

Leakage current: ≤ 0.1 mA

ON delay: ≤ 0.5 msec.

OFF delay: ≤ 0.5 msec.

Overload current protection function: Limits the current value when overcurrent is detected

Overheat Protection Function:

Turns OFF the output when overheat is detected

TERMINAL ASSIGNMENTS

■ Output Connection

PIN No	ID	FUNCTION	PIN No	ID	FUNCTION
Y0	1	Y0	Y8	1	Y8
	2	+24V		2	+24V
	3	GND		3	GND
Y1	1	Y1	Y9	1	Y9
	2	+24V		2	+24V
	3	GND		3	GND
Y2	1	Y2	YA	1	YA
	2	+24V		2	+24V
	3	GND		3	GND
Y3	1	Y3	YB	1	YB
	2	+24V		2	+24V
	3	GND		3	GND
Y4	1	Y4	YC	1	YC
	2	+24V		2	+24V
	3	GND		3	GND
Y5	1	Y5	YD	1	YD
	2	+24V		2	+24V
	3	GND		3	GND
Y6	1	Y6	YE	1	YE
	2	+24V		2	+24V
	3	GND		3	GND
Y7	1	Y7	YF	1	YF
	2	+24V		2	+24V
	3	GND		3	GND

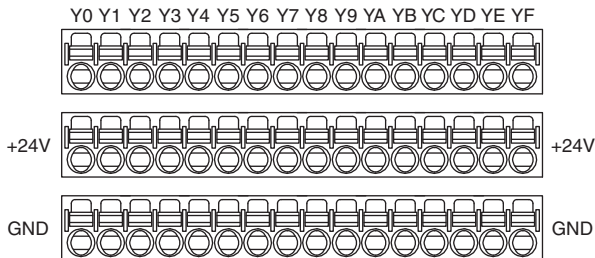

SCHEMATIC CIRCUITRY

Note: In order to improve EMC performance, bond the FE terminal to ground.

Caution: FE terminal is NOT a protective conductor terminal.

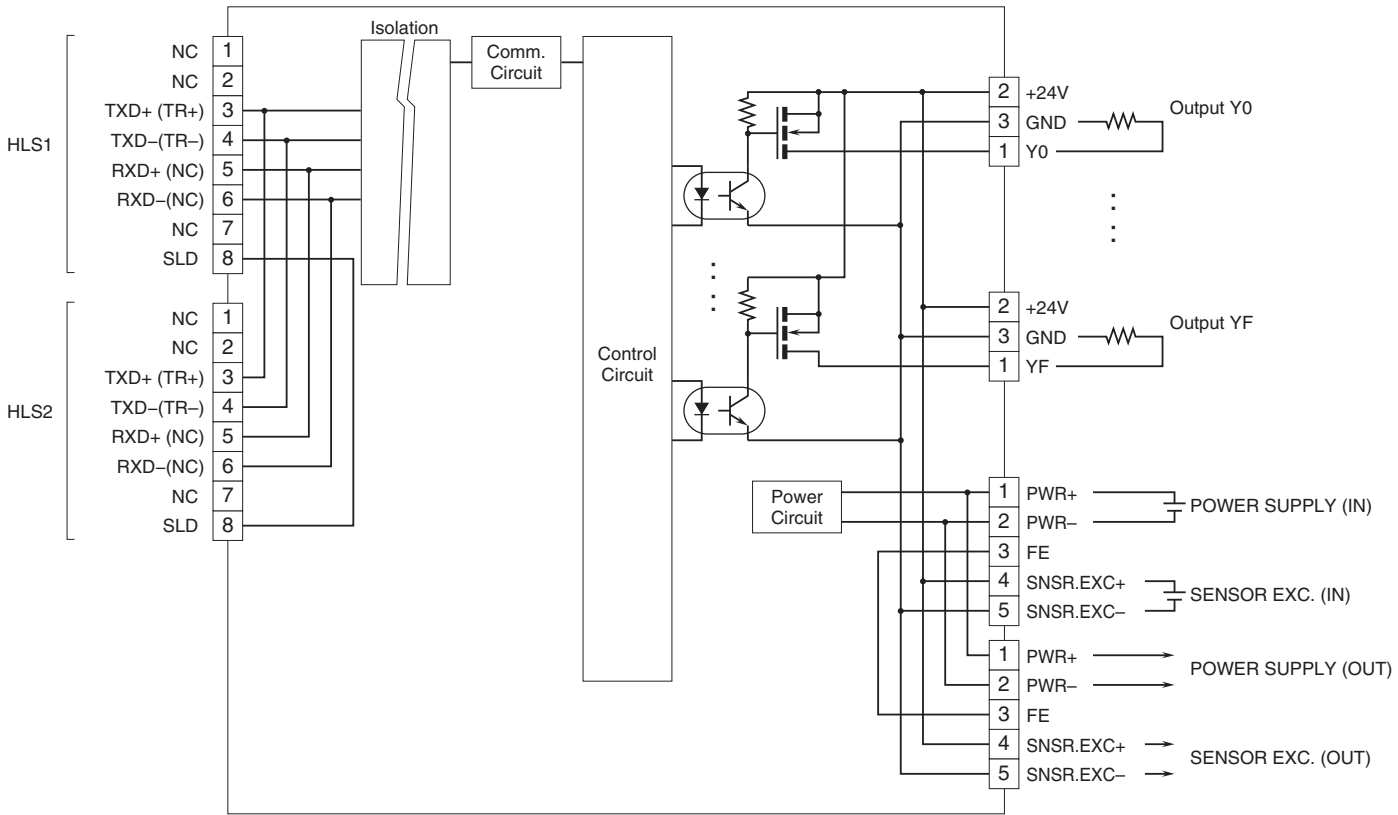

PNP DISCRETE INPUT & NPN TRANSISTOR OUTPUT MODULE, 8 points each
(Tension clamp terminal block)

MODEL: R7F4DH-4-DAC16A

SPECIFICATIONS

■ COMMON SPECIFICATIONS

Common: Negative common per 16 points
Input rating/load voltage: 24 V DC $\pm 10\%$, ripple 5 %p-p max.
Number of I/O: Input, 8 points; Output, 8 points
Maximum I/O applicable at once: No limit (at 24 V DC)
I/O status indicator: LED turns on with closed contact.
Isolation: I/O or sensor excitation to HLS to power input to FE
Data allocation: 1

■ INPUT

ON voltage / current: ≥ 15 V DC (I/O's X0 through X7 to 0 V) / ≥ 3.5 mA
OFF voltage / current: ≤ 5 V DC (I/O's X0 through X7 to 0 V) / ≤ 1 mA
Input current: ≤ 5.5 mA per point at 24 V DC
Input resistance: Approx. 4.4 k Ω
ON delay: ≤ 0.5 msec.
OFF delay: ≤ 0.5 msec.

■ OUTPUT

Rated output current: 0.1 A per point, 0.8 A per common
Residual voltage: ≤ 1.2 V
Leakage current: ≤ 0.1 mA
ON delay: ≤ 0.5 msec.
OFF delay: ≤ 0.5 msec.
Overload current protection function: Limits the current value when overcurrent is detected
Overheat Protection Function: Turns OFF the output when overheat is detected

PIN No	ID	FUNCTION	PIN No	ID	FUNCTION
X0	1	X0	Y0	1	Y0
	2	+24V		2	+24V
	3	GND		3	GND
X1	1	X1	Y1	1	Y1
	2	+24V		2	+24V
	3	GND		3	GND
X2	1	X2	Y2	1	Y2
	2	+24V		2	+24V
	3	GND		3	GND
X3	1	X3	Y3	1	Y3
	2	+24V		2	+24V
	3	GND		3	GND
X4	1	X4	Y4	1	Y4
	2	+24V		2	+24V
	3	GND		3	GND
X5	1	X5	Y5	1	Y5
	2	+24V		2	+24V
	3	GND		3	GND
X6	1	X6	Y6	1	Y6
	2	+24V		2	+24V
	3	GND		3	GND
X7	1	X7	Y7	1	Y7
	2	+24V		2	+24V
	3	GND		3	GND

TERMINAL ASSIGNMENTS

■ I/O Connection

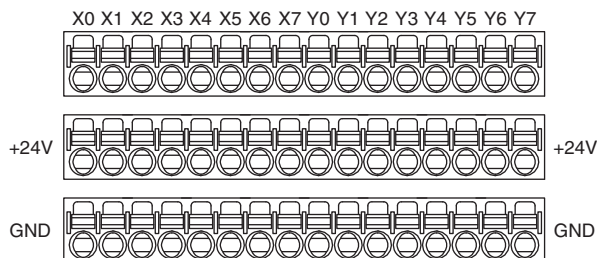

SCHEMATIC CIRCUITRY

Note: In order to improve EMC performance, bond the FE terminal to ground.

Caution: FE terminal is NOT a protective conductor terminal.

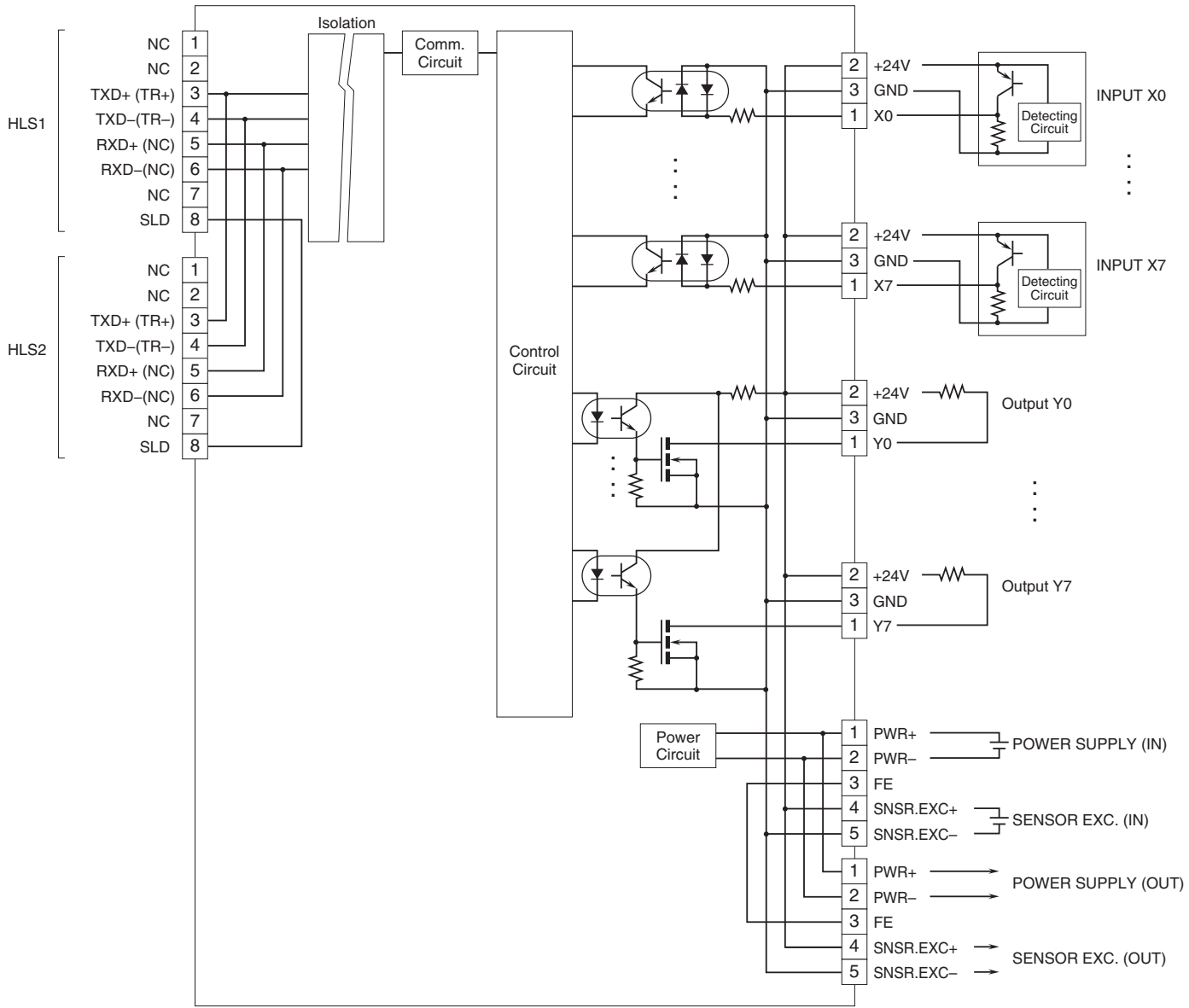

■ 2-Wire Sensor

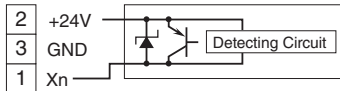

NPN DISCRETE INPUT & PNP TRANSISTOR OUTPUT MODULE, 8 points each
(Tension clamp terminal block)

MODEL: R7F4DH-4-DAC16B

SPECIFICATIONS

■ COMMON SPECIFICATIONS

Common: Positive common per 16 points
Input rating/load voltage: 24 V DC $\pm 10\%$, ripple 5 %p-p max.
Number of I/O: Input, 8 points; Output, 8 points
Maximum I/O applicable at once: No limit (at 24 V DC)
I/O status indicator: LED turns on with closed contact.
Isolation: I/O or sensor excitation to HLS to power input to FE
Data allocation: 1

■ INPUT

ON voltage / current: ≥ 15 V DC (I/O's X0 through X7 to +24 V) / ≥ 3.5 mA
OFF voltage / current: ≤ 5 V DC (I/O's X0 through X7 to +24 V) / ≤ 1 mA
Input current: ≤ 5.5 mA per point at 24 V DC
Input resistance: Approx. 4.4 k Ω
ON delay: ≤ 0.5 msec.
OFF delay: ≤ 0.5 msec.

■ OUTPUT

Rated output current: 0.1 A per point, 0.8 A per common
Residual voltage: ≤ 1.2 V
Leakage current: ≤ 0.1 mA
ON delay: ≤ 0.5 msec.
OFF delay: ≤ 0.5 msec.
Overload current protection function: Limits the current value when overcurrent is detected
Overheat Protection Function:
 Turns OFF the output when overheat is detected

PIN No	ID	FUNC-TION	PIN No	ID	FUNC-TION
X0	1	X0	Y0	1	Y0
	2	+24V		2	+24V
	3	GND		3	GND
X1	1	X1	Y1	1	Y1
	2	+24V		2	+24V
	3	GND		3	GND
X2	1	X2	Y2	1	Y2
	2	+24V		2	+24V
	3	GND		3	GND
X3	1	X3	Y3	1	Y3
	2	+24V		2	+24V
	3	GND		3	GND
X4	1	X4	Y4	1	Y4
	2	+24V		2	+24V
	3	GND		3	GND
X5	1	X5	Y5	1	Y5
	2	+24V		2	+24V
	3	GND		3	GND
X6	1	X6	Y6	1	Y6
	2	+24V		2	+24V
	3	GND		3	GND
X7	1	X7	Y7	1	Y7
	2	+24V		2	+24V
	3	GND		3	GND

TERMINAL ASSIGNMENTS

■ I/O Connection

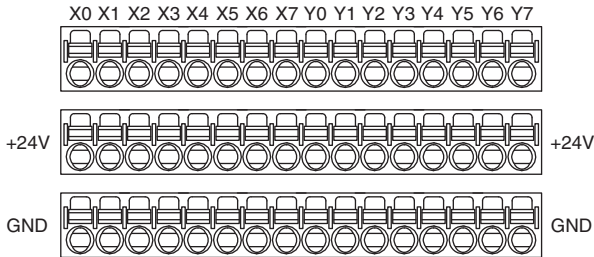

SCHEMATIC CIRCUITRY

Note: In order to improve EMC performance, bond the FE terminal to ground.

Caution: FE terminal is NOT a protective conductor terminal.

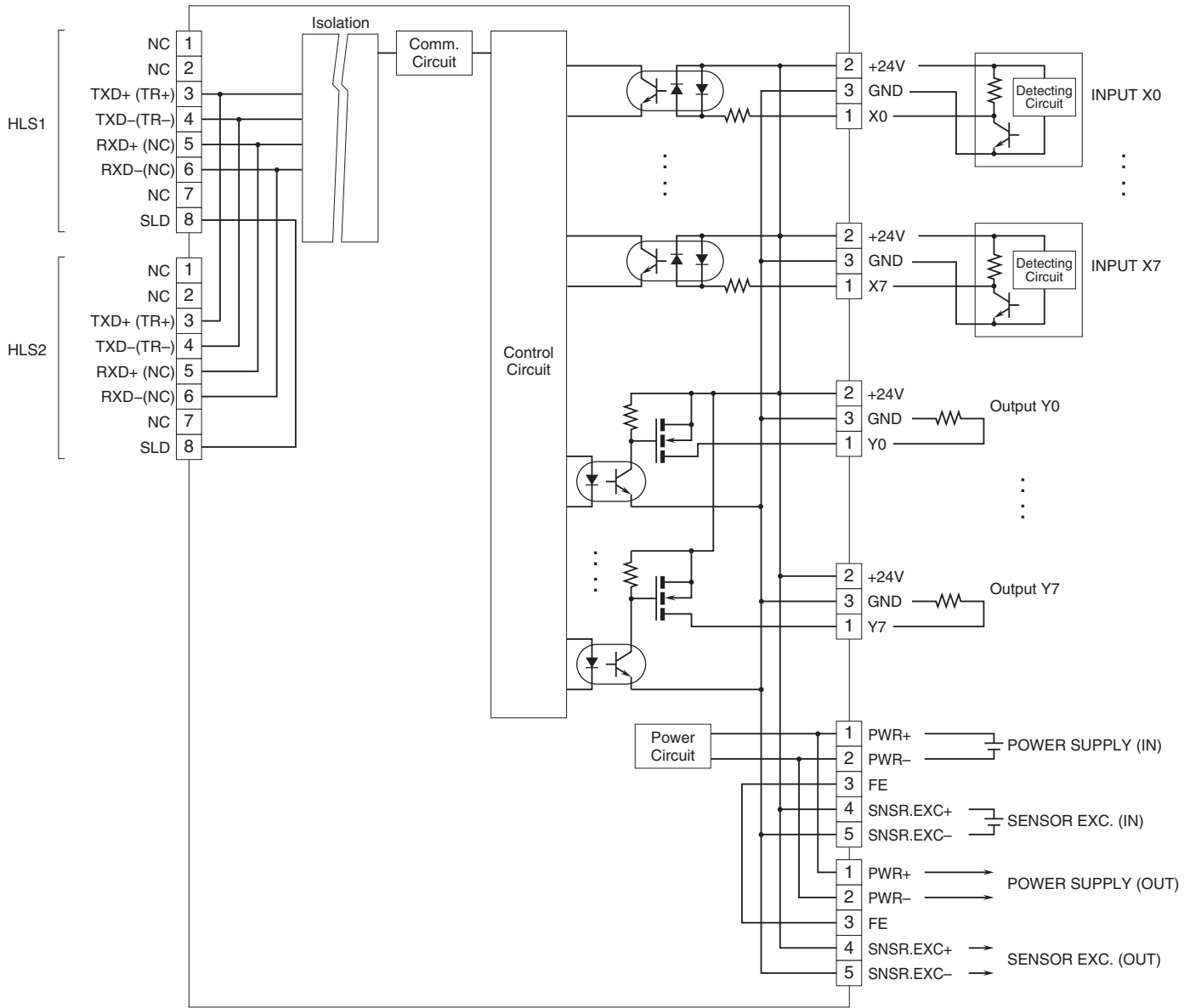

■ 2-Wire Sensor

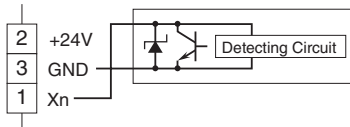

NPN DISCRETE INPUT & NPN TRANSISTOR OUTPUT MODULE, 8 points each

(Tension clamp terminal block)

MODEL: R7F4DH-4-DAC16C

SPECIFICATIONS

COMMON SPECIFICATIONS

- Input common:** Positive common per 8 points
- Output common:** Negative common per 8 points
- Input rating/load voltage:** 24 V DC $\pm 10\%$, ripple 5 %p-p max.
- Number of I/O:** Input, 8 points; Output, 8 points
- Maximum I/O applicable at once:** No limit (at 24 V DC)
- I/O status indicator:** LED turns on with closed contact.
- Isolation:** I/O or sensor excitation to HLS to power input to FE
- Data allocation:** 1
- ##### INPUT

 - ON voltage / current:** ≥ 15 V DC (I/O's X0 through X7 to +24 V) / ≥ 3.5 mA
 - OFF voltage / current:** ≤ 5 V DC (I/O's X0 through X7 to +24 V) / ≤ 1 mA
 - Input current:** ≤ 5.5 mA per point at 24 V DC
 - Input resistance:** Approx. 4.4 k Ω
 - ON delay:** ≤ 0.5 msec.
 - OFF delay:** ≤ 0.5 msec.
- ##### OUTPUT

 - Rated output current:** 0.1 A per point, 0.8 A per common
 - Residual voltage:** ≤ 1.2 V
 - Leakage current:** ≤ 0.1 mA
 - ON delay:** ≤ 0.5 msec.
 - OFF delay:** ≤ 0.5 msec.
 - Overload current protection function:** Limits the current value when overcurrent is detected
 - Overheat Protection Function:** Turns OFF the output when overheat is detected

PIN No	ID	FUNCTION	PIN No	ID	FUNCTION
X0	1	X0	Y0	1	Y0
	2	+24V		2	+24V
	3	GND		3	GND
X1	1	X1	Y1	1	Y1
	2	+24V		2	+24V
	3	GND		3	GND
X2	1	X2	Y2	1	Y2
	2	+24V		2	+24V
	3	GND		3	GND
X3	1	X3	Y3	1	Y3
	2	+24V		2	+24V
	3	GND		3	GND
X4	1	X4	Y4	1	Y4
	2	+24V		2	+24V
	3	GND		3	GND
X5	1	X5	Y5	1	Y5
	2	+24V		2	+24V
	3	GND		3	GND
X6	1	X6	Y6	1	Y6
	2	+24V		2	+24V
	3	GND		3	GND
X7	1	X7	Y7	1	Y7
	2	+24V		2	+24V
	3	GND		3	GND

TERMINAL ASSIGNMENTS

I/O Connection

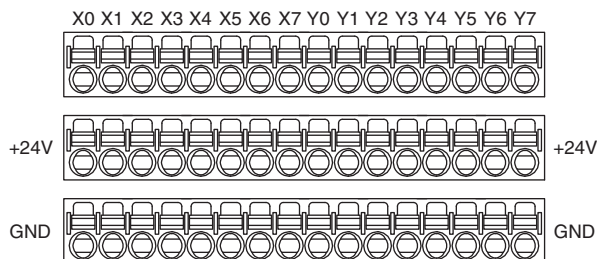

SCHEMATIC CIRCUITRY

Note: In order to improve EMC performance, bond the FE terminal to ground.

Caution: FE terminal is NOT a protective conductor terminal.

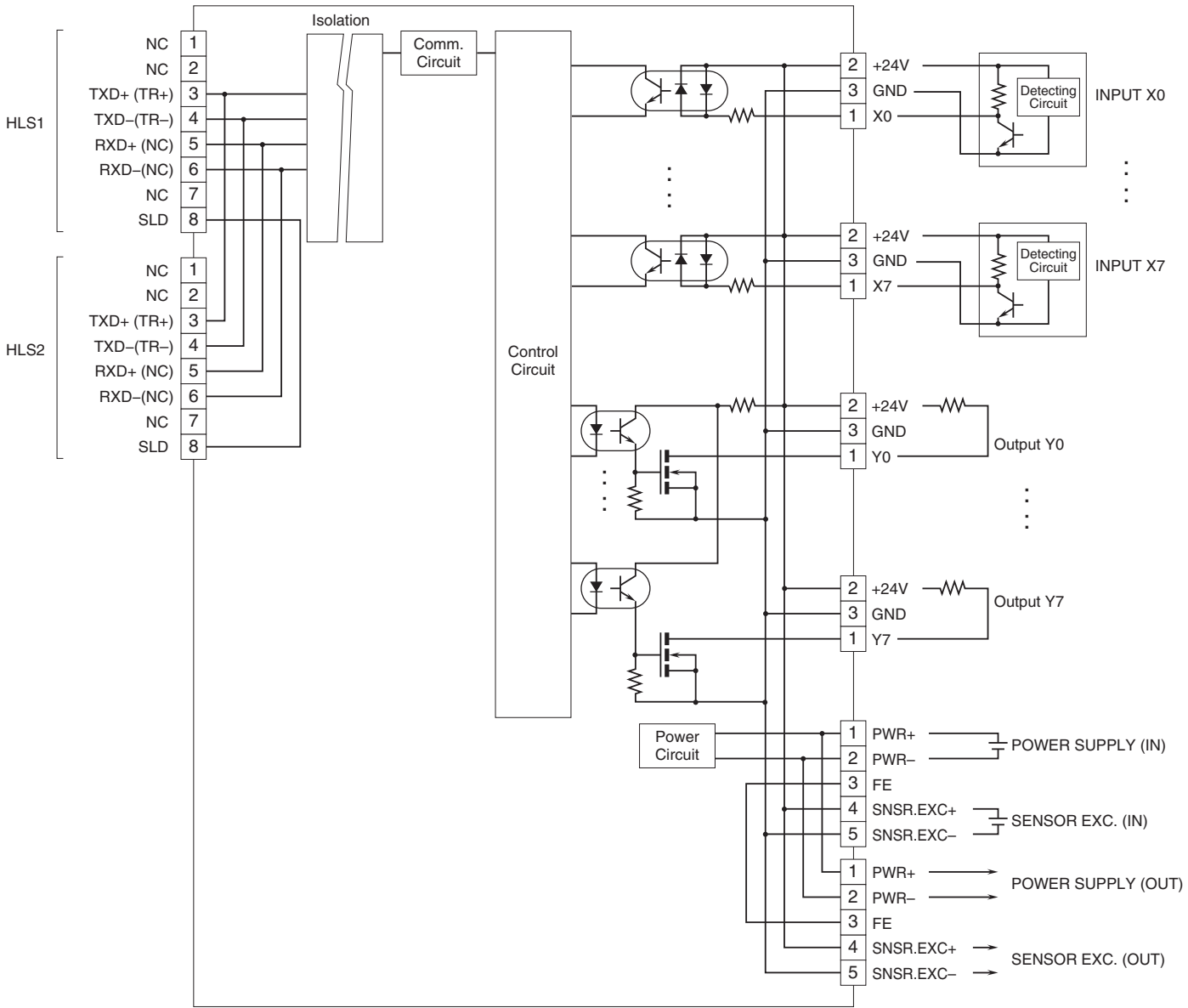

■ 2-Wire Sensor

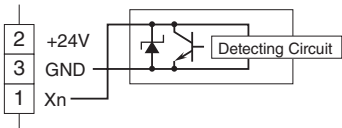

PNP DISCRETE INPUT & PNP TRANSISTOR OUTPUT MODULE, 8 points each

(Tension clamp terminal block)

MODEL: R7F4DH-4-DAC16D

SPECIFICATIONS

COMMON SPECIFICATIONS

- Input common:** Negative common per 8 points
- Output common:** Positive common per 8 points
- Input rating/load voltage:** 24 V DC $\pm 10\%$, ripple 5 %p-p max.
- Number of I/O:** Input, 8 points; Output, 8 points
- Maximum I/O applicable at once:** No limit (at 24 V DC)
- I/O status indicator:** LED turns on with closed contact.
- Isolation:** I/O or sensor excitation to HLS to power input to FE
- Data allocation:** 1
- ##### INPUT

 - ON voltage / current:** ≥ 15 V DC (I/O's X0 through X7 to 0 V) / ≥ 3.5 mA
 - OFF voltage / current:** ≤ 5 V DC (I/O's X0 through X7 to 0 V) / ≤ 1 mA
 - Input current:** ≤ 5.5 mA per point at 24 V DC
 - Input resistance:** Approx. 4.4 k Ω
 - ON delay:** ≤ 0.5 msec.
 - OFF delay:** ≤ 0.5 msec.
- ##### OUTPUT

 - Rated output current:** 0.1 A per point, 0.8 A per common
 - Residual voltage:** ≤ 1.2 V
 - Leakage current:** ≤ 0.1 mA
 - ON delay:** ≤ 0.5 msec.
 - OFF delay:** ≤ 0.5 msec.
 - Overload current protection function:** Limits the current value when overcurrent is detected
 - Overheat Protection Function:** Turns OFF the output when overheat is detected

PIN No	ID	FUNCTION	PIN No	ID	FUNCTION
X0	1	X0	Y0	1	Y0
	2	+24V		2	+24V
	3	GND		3	GND
X1	1	X1	Y1	1	Y1
	2	+24V		2	+24V
	3	GND		3	GND
X2	1	X2	Y2	1	Y2
	2	+24V		2	+24V
	3	GND		3	GND
X3	1	X3	Y3	1	Y3
	2	+24V		2	+24V
	3	GND		3	GND
X4	1	X4	Y4	1	Y4
	2	+24V		2	+24V
	3	GND		3	GND
X5	1	X5	Y5	1	Y5
	2	+24V		2	+24V
	3	GND		3	GND
X6	1	X6	Y6	1	Y6
	2	+24V		2	+24V
	3	GND		3	GND
X7	1	X7	Y7	1	Y7
	2	+24V		2	+24V
	3	GND		3	GND

TERMINAL ASSIGNMENTS

I/O Connection

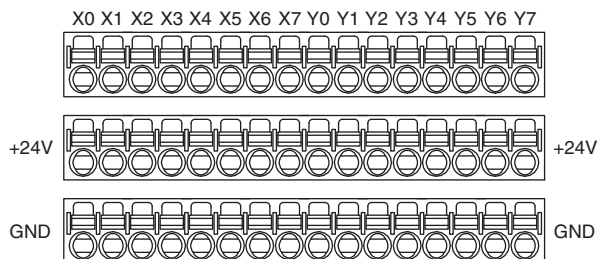

SCHEMATIC CIRCUITRY

Note: In order to improve EMC performance, bond the FE terminal to ground.

Caution: FE terminal is NOT a protective conductor terminal.

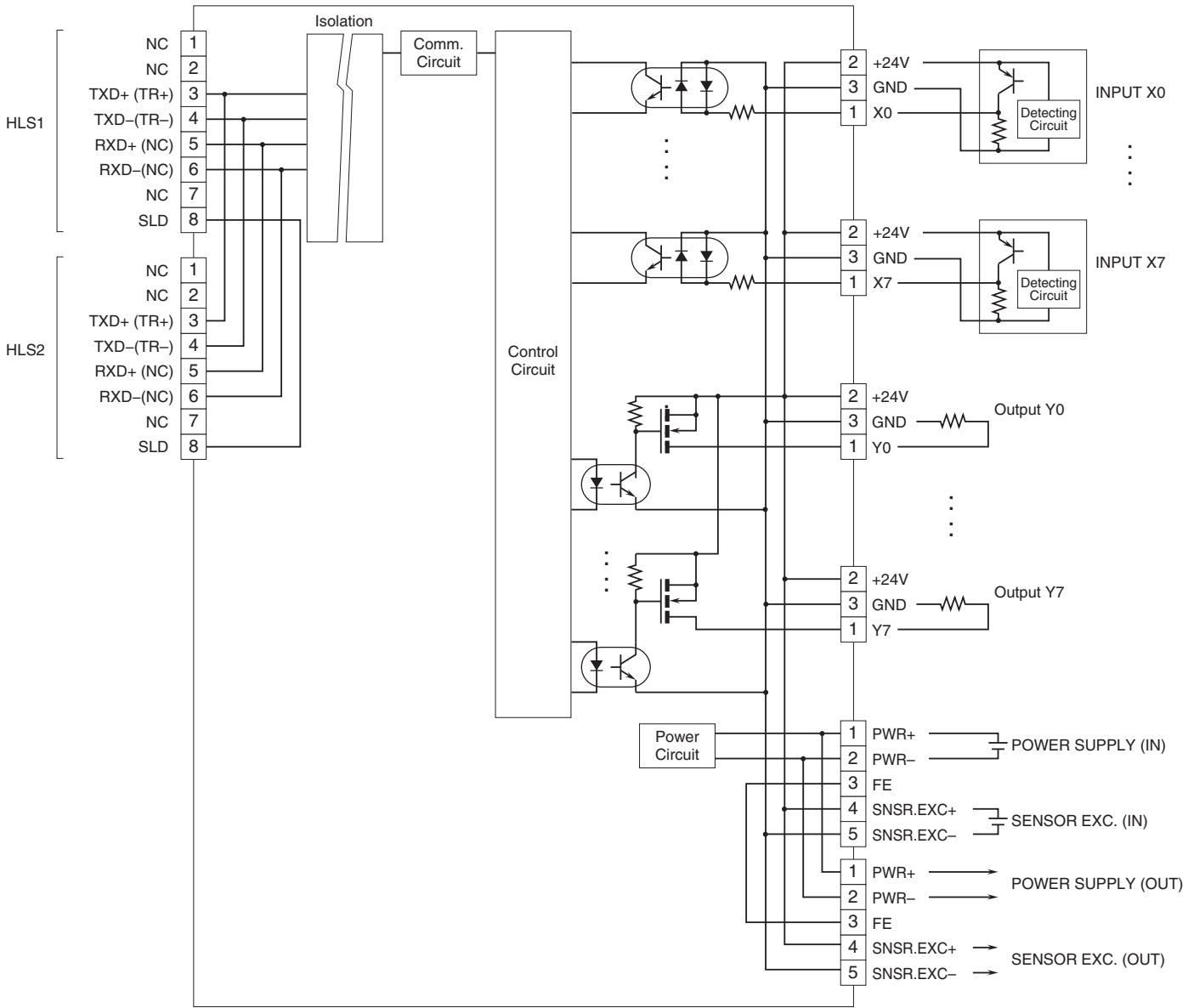

■ 2-Wire Sensor

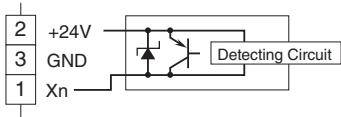

 Specifications are subject to change without notice.

