

## Remote I/O R7 Series

### ETHERNET I/O MODULE

(Modbus/TCP)

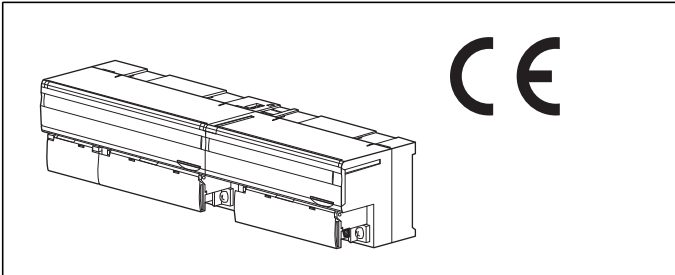

### ORDERING INFORMATION

- Basic module: R7E-[1]-R  
Specify a code from below for [1].  
(e.g. R7E-DC16A-R)
- Extension module: R7E-[1]  
Specify a code from below for [1].  
(e.g. R7E-EC16B)

### BASIC MODULE: R7E-[1]-R

#### [1] I/O TYPE

- DA16:** Discrete input, 16 points
- DC16A:** NPN transistor output, 16 points
- DC16B:** PNP transistor output, 16 points
- SV4:** DC voltage/current input (10 V/20 mA), 4 points
- TS4:** Thermocouple input, 4 points
- RS4:** RTD input, 4 points
- MS4:** Potentiometer input, 4 points
- CT4E:** AC current input, 4 points, clamp-on current sensor CLSE use
- YV2:** DC voltage output, 2 points
- YS2:** DC current output, 2 points

#### POWER INPUT

**DC Power**  
R: 24 V DC

### EXTENSION MODULE: R7E-[1]

#### [1] I/O TYPE

- EA8:** Discrete input, 8 points
- EA16:** Discrete input, 16 points
- EC8A:** NPN transistor output, 8 points
- EC16A:** NPN transistor output, 16 points
- EC8B:** PNP transistor output, 8 points

**EC16B:** PNP transistor output, 16 points

### FUNCTIONS & FEATURES

The R7E interfaces analog and discrete I/O signals with a PLC or PC via Ethernet Modbus/TCP network. A 'basic' module can be attached with an 'extension' module. By combining two modules, single station can handle mixed analog and discrete signals, 32-point discrete inputs, 32-point discrete outputs, 16-point discrete I/Os and other combinations of signals. Input sensor type (thermocouple, RTD) and range can be selected with the front DIP switches for all channels. In order to set different selections for individual channels, the PC Configurator Software (model: R7CON) is used.

### RELATED PRODUCTS

- PC configurator software (model: R7CON)  
Downloadable at M-System's web site.  
A dedicated cable is required to connect the module to the PC. Please refer to the internet software download site or the users manual for the PC configurator for applicable cable types.
- Clamp-on current sensor (model: CLSE)  
For R7E-CT4E, the clamp-on current sensors must be ordered separately. Required number depends upon the channel number.  
Note: PC Configurator Software is required to set IP address.

### GENERAL SPECIFICATIONS

- **Common Specifications**
- Power input:** 24 V DC  $\pm 10\%$
- Insulation resistance:**  $\geq 100\text{ M}\Omega$  with 500 V DC
- Dielectric strength:** 1500 V AC @1 minute (between isolated circuits)
- Operating temperature:** -10 to +55°C (14 to 131°F)
- Operating humidity:** 30 to 90 %RH (non-condensing)
- Atmosphere:** No corrosive gas or heavy dust
- Storage temperature:** -20 to +65°C (-4 to +149°F)
- Mounting:** DIN rail (35 mm wide)
- Connection**
- Ethernet:** RJ-45 connector
- Power & I/O:** M3 separable screw terminals (torque 0.5 N·m)
- Screw terminal material:** Nickel-plated steel
- Solderless terminal:** Refer to the drawing at the end of the section.
- Recommended manufacturer:** Japan Solderless Terminal MFG.Co.Ltd, Nichifu Co.,Ltd
- Applicable wire size:** 0.25 to 1.65 mm<sup>2</sup> (AWG 22 to 16)
- Status indicator LEDs:** PWR, RUN



## ■ Current Consumption & Weight

(Current consumption at 24 V DC and weight )

R7E-DA16: Approx. 74 mA, 200 g (7.0 oz)  
R7E-DC16A: Approx. 86 mA, 200 g (7.0 oz)  
R7E-DC16B: Approx. 86 mA, 200 g (7.0 oz)  
R7E-SV4: Approx. 97 mA, 200 g (7.0 oz)  
R7E-TS4: Approx. 97 mA, 200 g (7.0 oz)  
R7E-RS4: Approx. 97 mA, 200 g (7.0 oz)  
R7E-MS4: Approx. 97 mA, 200 g (7.0 oz)  
R7E-CT4E: Approx. 109 mA, 200 g (7.0 oz)  
R7E-YV2: Approx. 115 mA, 180 g (6.3 oz)  
R7E-YS2: Approx. 161 mA, 180 g (6.3 oz)  
R7E-EA8: Approx. 10 mA, 90 g (3.2 oz)  
R7E-EA16: Approx. 20 mA, 150 g (5.3 oz)  
R7E-EC8A: Approx. 10 mA, 90 g (3.2 oz)  
R7E-EC16A: Approx. 20 mA, 150 g (5.3 oz)  
R7E-EC8B: Approx. 10 mA, 90 g (3.2 oz)  
R7E-EC16B: Approx. 20 mA, 150 g (5.3 oz)

## ■ Recommended solderless terminal

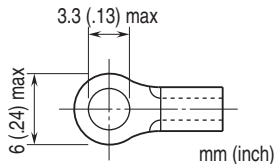

## ETHERNET COMMUNICATION

**Physical layer standard:** IEEE 802.3u

**Data link layer:** 10BASE-T / 100BASE-TX

**Baud rate:** 10 / 100 Mbps, Auto Negotiation

**Protocol:** Modbus/TCP

**Data:** RTU (binary)

**Max. number of socket connections:** Two (2)

**Transmission media:** 10BASE-T (STP cable, category 5)

100BASE-TX (STP cable, category 5e)

**Max. segment length:** 100 meters

**IP address:** 192.168.0.1 (factory setting); Selectable with PC Configurator Software (model: R7CON)

**Port No.:** 502

**Ethernet indicator LED:** LINK, LINK100, COL

## STANDARDS & APPROVALS

**CE conformity:**

EMC Directive (2004/108/EC)

EMI EN 61000-6-4: 2007/A1: 2011

EMS EN 61000-6-2: 2005



## EXTERNAL VIEW

### ■ BASIC MODULE

#### • SIDE VIEW

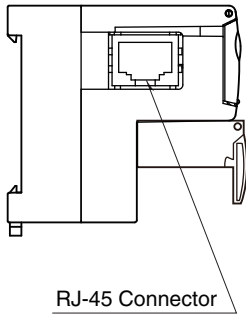

#### • FRONT VIEW

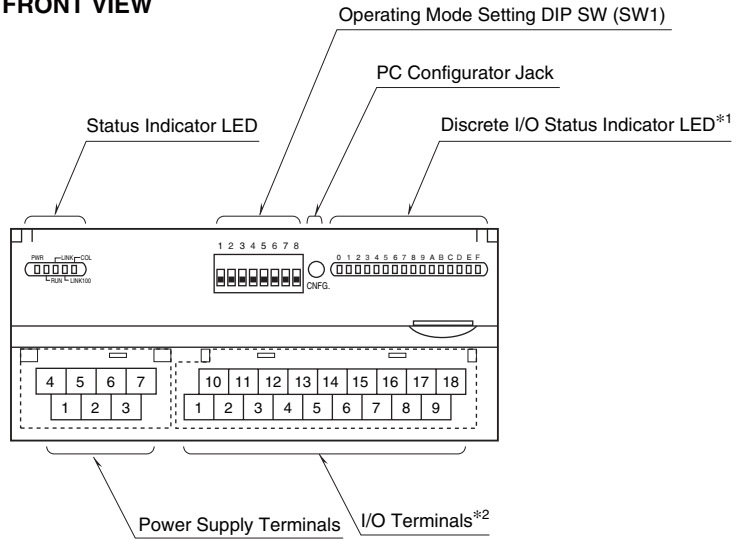

\*1. Not available with analog I/O modules.  
 \*2. 10 screw terminals for analog output modules.

### ■ EXTENSION MODULE

#### • DISCRETE, 8 POINTS

Discrete I/O Status Indicator LED

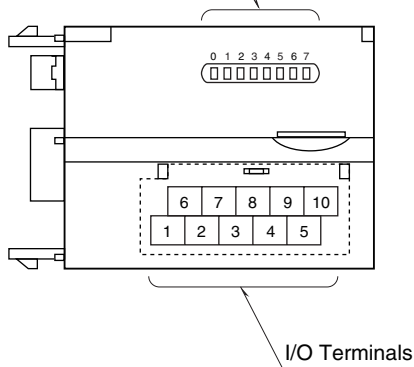

• DISCRETE, 16 POINTS

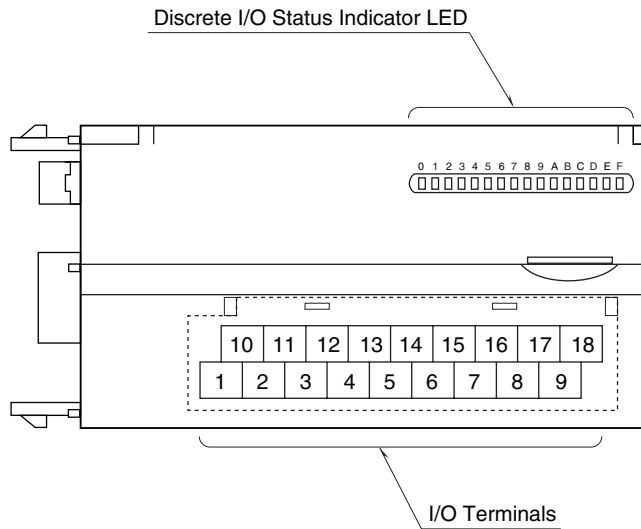

■ DISCRETE I/O STATUS INDICATOR LED

Discrete I/O modules, including those for extensions, have LED indicators showing I/O signal status.

Contact ON : LED ON

Contact OFF : LED OFF

**CONNECTION DIAGRAMS**

■ POWER SUPPLY TERMINAL ASSIGNMENT

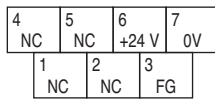

NO.	ID	FUNCTION, NOTES
1	NC	----
2	NC	----
3	FG	FG
4	NC	----
5	NC	----
6	+24 V	Power input (24 V DC)
7	0 V	Power input (0 V)



**MODBUS FUNCTION CODES & SUPPORTED CODES****■ DATA & CONTROL FUNCTIONS**

CODE	NAME		
01	Read Coil Status	X	Digital output from the slave (read/write)
02	Read Input Status	X	Status of digital inputs to the slave (read only)
03	Read Holding Registers	X	General purpose register within the slave (read/write)
04	Read Input Registers	X	Collected data from the field by the slave (read only)
05	Force Single Coil	X	Digital output from the slave (read/write)
06	Preset Single Registers	X	General purpose register within the slave (read/write)
07	Read Exception Status		
08	Diagnostics	X	
09	Program 484		
10	Poll 484		
11	Fetch Comm. Event Counter	X	Fetch a status word and an event counter
12	Fetch Comm. Event Log	X	A status word, an event counter, a message count and a field of event bytes
13	Program Controller		
14	Poll Controller		
15	Force Multiple Coils	X	Digital output from the slave (read/write)
16	Preset Multiple Registers	X	General purpose register within the slave (read/write)
17	Report Slave ID	X	Slave type/ 'RUN' Status
18	Program 884/M84		
19	Reset Comm. Link		
20	Read General Reference		
21	Write General Reference		
22	Mask Write 4X Register		
23	Read/Write 4X Register		
24	Read FIFO Queue		

**■ Exception Code**

CODE	NAME		
01	Illegal Function	X	Function code is not allowable for the slave
02	Illegal Data Address	X	Address is not available within the slave
03	Illegal Data Value	X	Data is not valid for the function
04	Slave Device Failure		
05	Acknowledge		
06	Slave Device Busy		
07	Negative Acknowledge		
08	Memory Parity Error		

**■ Diagnostic Subfunctions**

CODE	NAME		
00	Return Query Data	X	Loop back test
01	Restart Comm. Option		
02	Return Diagnostic Register		
03	Change Input Delimiter Character		
04	Force Slave to Listen Only Mode		



**MODBUS I/O ASSIGNMENTS**

	ADDRESS	DATA TYPE	DATA
Coil (0X)	1 – 16		Digital Output (discrete output of the basic module)
	17 – 32		Digital Output (discrete output of the extension module)
Inputs (1X)	1 – 16		Digital Input (discrete input of the basic module)
	17 – 32		Digital Input (discrete input of the extension module)
	33 – 48		Reserved (unused)
	49 – 64		Module Status
	65 – 80		Reserved (unused)
Input Registers (3X)	1 – 4	I	Analog Input
	5 – 16	----	Reserved (unused)
	17 – 24	F	Analog Input
	25 – 48	----	Reserved (unused)
Holding Registers (4X)	1 – 2	I	Analog Output
	3 – 16	----	Reserved (unused)
	17 – 20	F	Analog Output
	21 – 48	----	Reserved (unused)

I : Integer, -1500 – 11500 (-15 – 115%)

F : Floating

Note: DO NOT access addresses other than mentioned above. Such access may cause problems such as inadequate operation.

**■ STATUS**

Analog input modules (models: R7E-SV4, R7E-TS4, R7E-RS4, R7E-MS4, R7E-CT4E) can show input status of each channel.

Analog output modules (models: R7E-YS2, R7E-YV2) and discrete I/O modules (models: R7E-DA16, R7E-DC16A, R7E-DC16B) shows '0' at the same address.

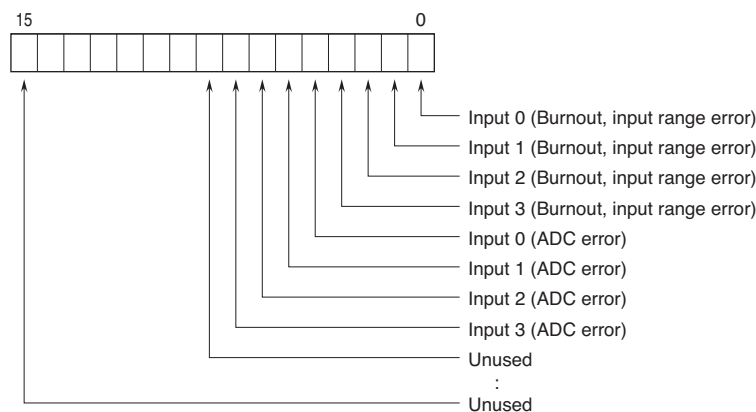

Burnout, input range error ( $\leq -15\%$ ,  $\geq +115\%$ )

0 : Normal 1 : Error

ADC error (no response from ADC)

0 : Normal 1 : Error



**DATA CONVERSION**

**■ 0 – 100% DATA CONVERSION**

Analog input data is converted into digital representations of 0 – 100% proportional to each scaled range. The converted % values are multiplied by 100 and expressed in 16 bits.

Ovrerange input is possible from -15 to +115% of the nominal range. When the signal exceeds the limit, the data is fixed at -15% or +115% respectively. Negative value is represented in 2's complements.

• Input Range 0 – 5 V DC

Input Value	Input %	Converted Data, Decimal	Converted Data, Hex
≤ -0.75 V	-15%	-1500	FA24
0 V	0%	0	0
5 V	100%	10000	2710
≥ 5.75 V	115%	11500	2CEC

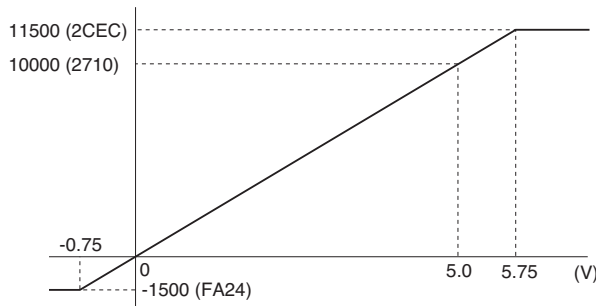

Analog output is converted in the reverse order of the input data. The output range 0 – 5 V DC is expressed as 10000 at 5.0 V (100%) and 0 at 0 V (0%).

**■ ENGINEERING UNIT CONVERSION**

Engineering unit value °C or K is multiplied by 10 and expressed in 16 bits. °F data is represented in engineering unit value, without multiplication. Engineering unit value A is multiplied by 100 or 1000, expressed in 16 bits. Negative value is represented in 2's complements.

• Input TYPE K Thermocouple

Input Value	Converted Data, Decimal	Converted Data, Hex
≤ -272°C	-2720	F560
-150°C	-1500	FA24
1370°C	13700	3584
≥ 1472°C	14720	3980

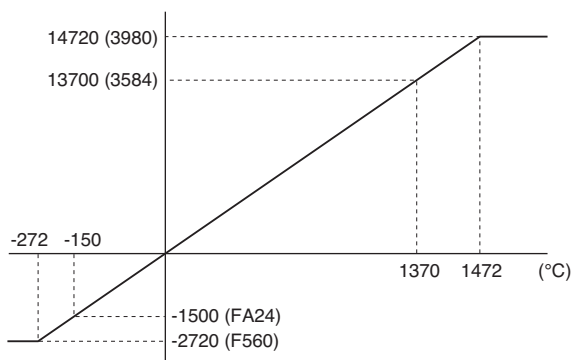

## EXTENSION MODULE

A 'basic' module can be attached with one 'extension' module. The extension module is powered from the basic module. By combining two modules, single station can handle mixed analog and discrete signals, 32-point discrete inputs, 32-point discrete outputs, 16-point discrete I/Os and other combinations of signals.

### ■ OUTPUT AT THE LOSS OF COMMUNICATION

The extension module is set to 'Hold Output' by factory default setting. The PC Configurator is used to change the setting to 'Reset Output.'

### ■ CONNECTING THE EXTENSION MODULE

- 1) Remove the extension connector cover located at the side of the basic module.
- 2) Connect the extension module.

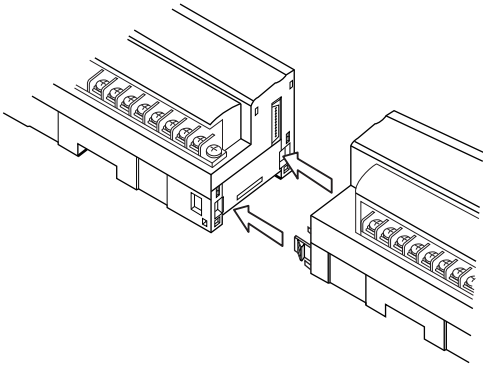

- 3) Mount the combined module on a DIN rail.

## DIMENSIONS unit: mm (inch)

### ■ BASIC MODULE

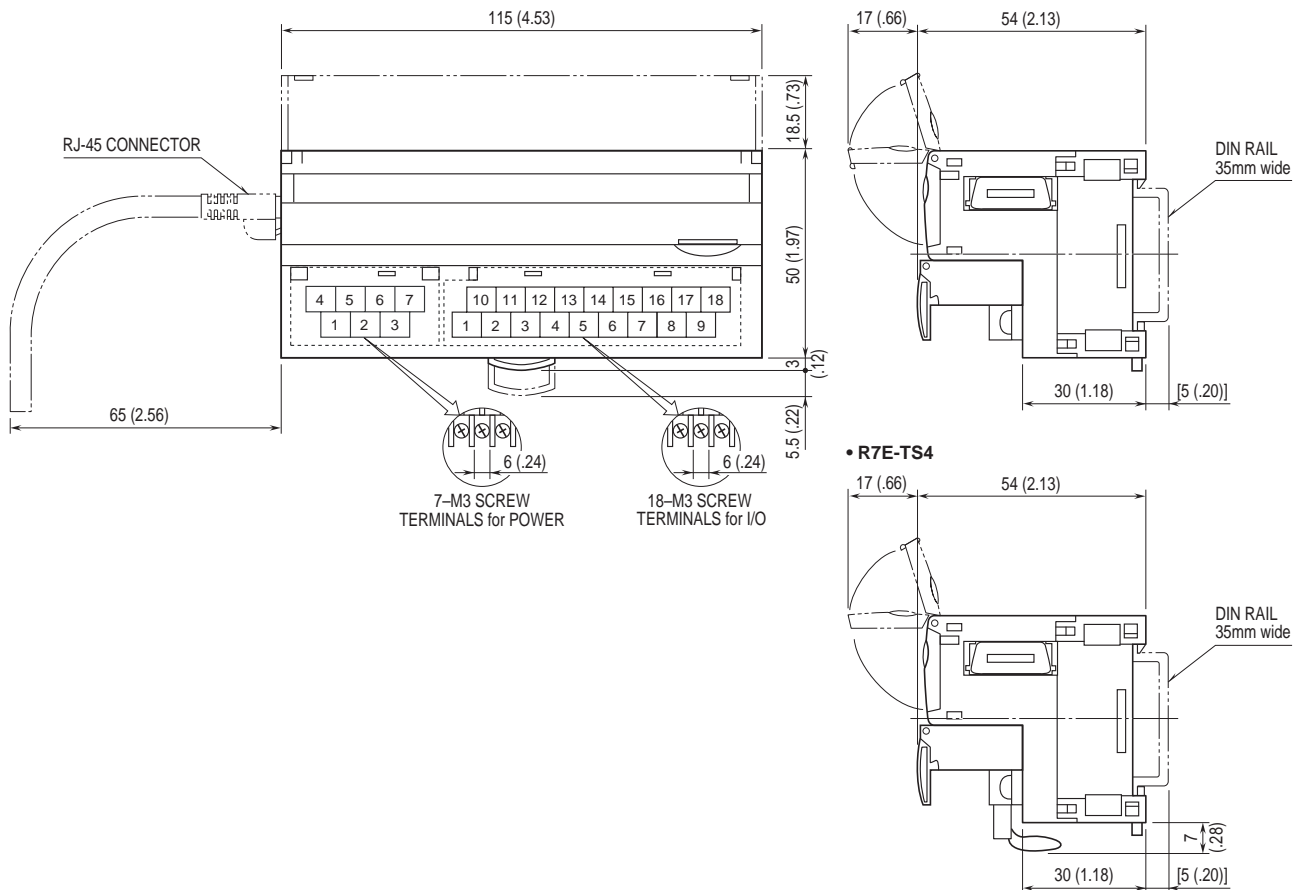



## ■ BASIC MODULE, ANALOG OUTPUT

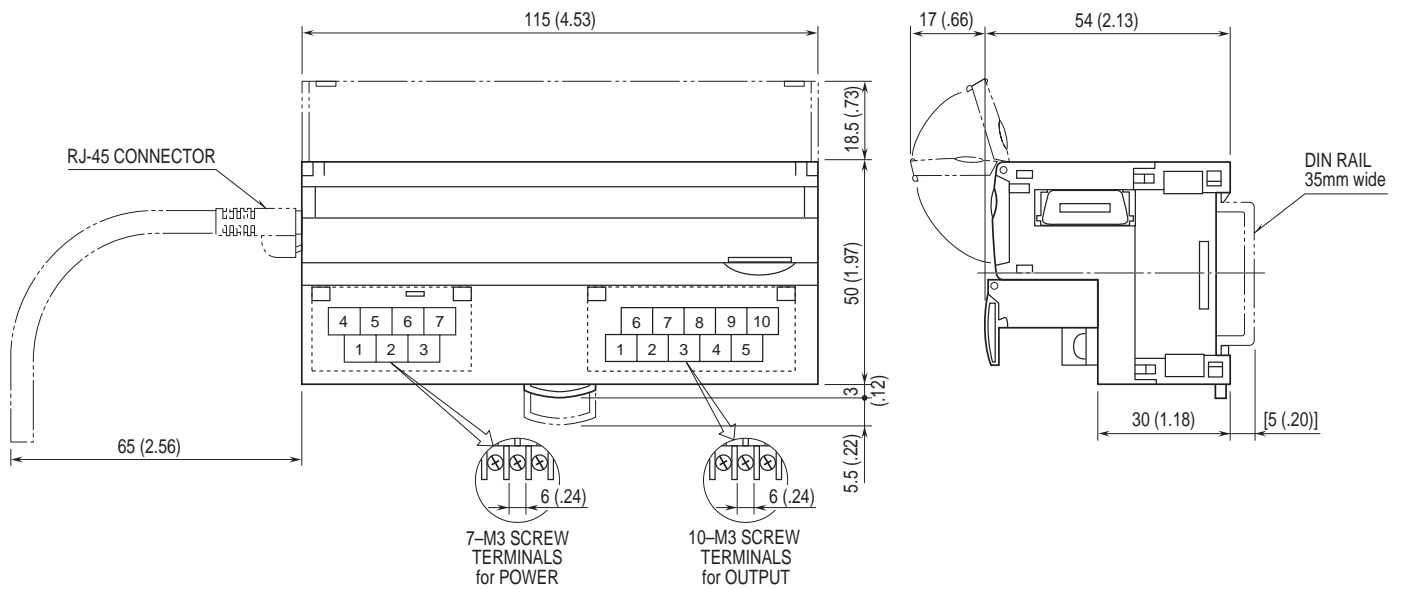

## ■ EXTENSION MODULE, 8 POINTS

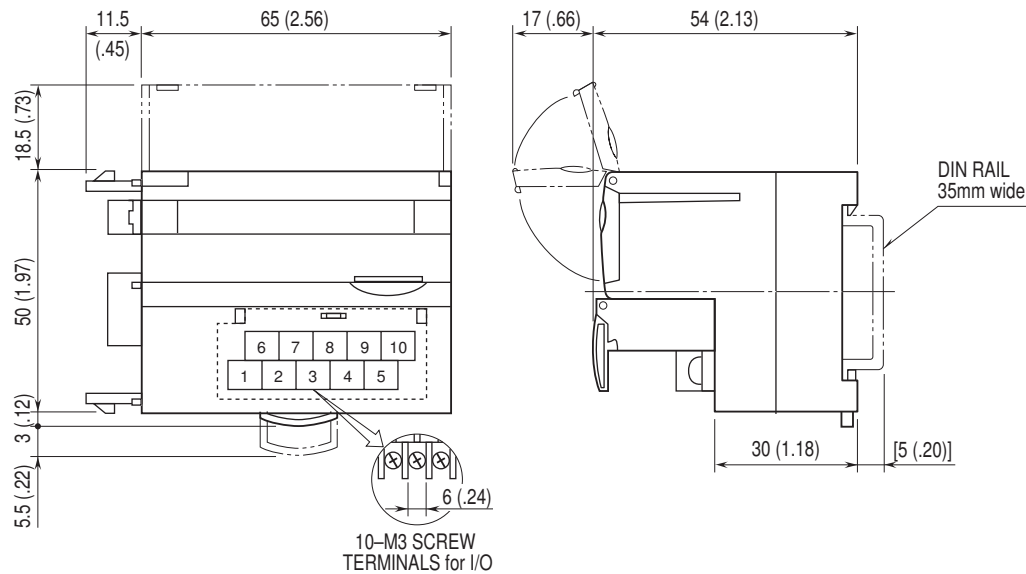

## ■ EXTENSION MODULE, 16 POINTS

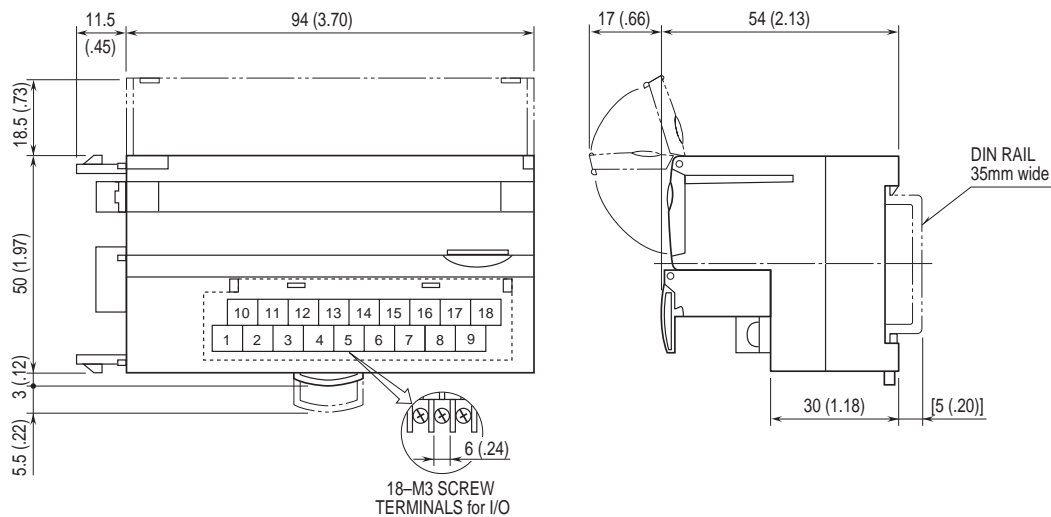

## DISCRETE INPUT MODULE, 16 points

### MODEL: R7E-DA16

#### SPECIFICATIONS

- Common:** Positive or negative common (PNP/NPN) per 16 points
- Number of I/O:** Input, 16 points
- Maximum inputs applicable at once:** No limit (at 24 V DC)
- Input status indicator LED:** Turns ON with contact ON
- Isolation:** Input to Ethernet to FG to power input
- Rated input voltage:** 24 V DC  $\pm 10\%$ ; ripple 5 %p-p max.
- ON voltage / current:**  $\geq 15$  V DC (input - COM) /  $\geq 3.5$  mA
- OFF voltage / current:**  $\leq 5$  V DC (input - COM) /  $\leq 1$  mA
- Input current:**  $\leq 5.5$  mA per point at 24 V DC
- Input resistance:** Approx. 4.4 k $\Omega$
- ON delay:**  $\leq 2.0$  msec.
- OFF delay:**  $\leq 2.0$  msec.

#### OPERATING MODE SETTING

(\*) Factory setting

Caution ! - SW1-3 through 1-8 are unused. Be sure to turn off unused ones.

• Extension (SW1-1, 1-2)

SW1-1	SW1-2	EXTENSION
OFF	OFF	No extension (*)
ON	OFF	Discrete input, 8 or 16 points
OFF	ON	Discrete output, 8 or 16 points

#### TERMINAL ASSIGNMENTS

10	11	12	13	14	15	16	17	18
NC	X1	X3	X5	X7	X9	XB	XD	XF
1	2	3	4	5	6	7	8	9
COM	X0	X2	X4	X6	X8	XA	XC	XE

NO.	ID	FUNCTION	NO.	ID	FUNCTION
1	COM	Common	10	NC	No Connection
2	X0	Input 0	11	X1	Input 1
3	X2	Input 2	12	X3	Input 3
4	X4	Input 4	13	X5	Input 5
5	X6	Input 6	14	X7	Input 7
6	X8	Input 8	15	X9	Input 9
7	XA	Input 10	16	XB	Input 11
8	XC	Input 12	17	XD	Input 13
9	XE	Input 14	18	XF	Input 15

#### CIRCUIT DIAGRAM

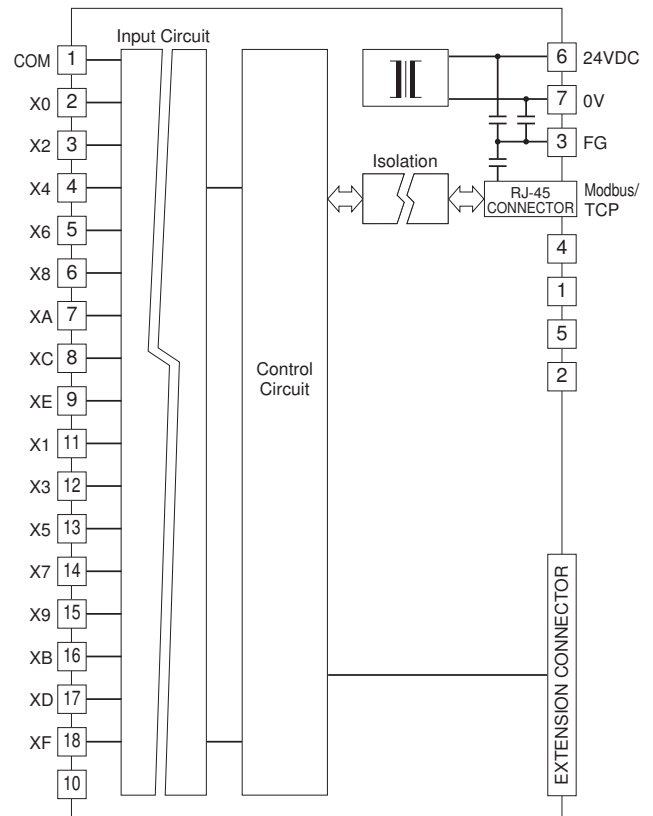

Input Circuit

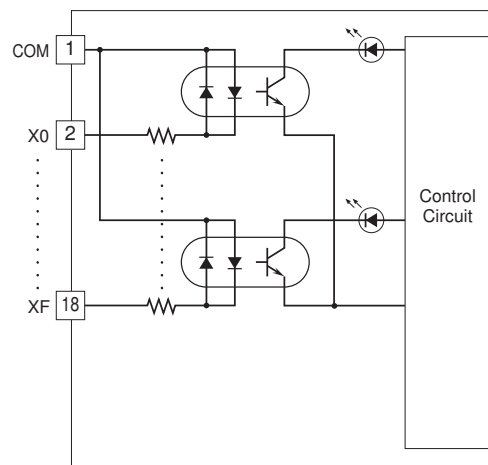

Input Connection Examples

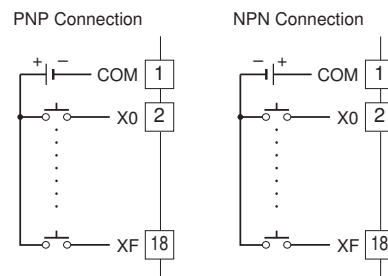

## NPN TRANSISTOR OUTPUT MODULE, 16 points

## CIRCUIT DIAGRAM

### MODEL: R7E-DC16A

### SPECIFICATIONS

- Common:** Negative common (NPN) per 16 points
- Number of I/O:** Output, 16 points
- Maximum outputs applicable at once:** No limit (at 24 V DC)
- Output status indicator LED:** Turns ON with contact ON
- Isolation:** Output to Ethernet to FG to power input
- Rated load voltage:** 24 V DC  $\pm 10\%$
- Rated output current:** 0.25 A per point, 2.0 A per common
- Residual voltage:**  $\leq 1.2$  V
- Leakage current:**  $\leq 0.1$  mA
- ON delay:**  $\leq 0.5$  msec.
- OFF delay:**  $\leq 1.5$  msec.

### OPERATING MODE SETTING

(\*) Factory setting

Caution ! - SW1-3, 1-5 through 1-8 are unused. Be sure to turn off unused ones.

#### • Output at the loss of communication (SW1-4)

SW1-4	OUTPUT AT THE LOSS OF COMMUNICATION
OFF	Reset the output (turned off)
ON	Hold the output (*) (maintains the last data received normally)

#### • Extension (SW1-1, 1-2)

SW1-1	SW1-2	EXTENSION
OFF	OFF	No extension (*)
ON	OFF	Discrete input, 8 or 16 points
OFF	ON	Discrete output, 8 or 16 points

### TERMINAL ASSIGNMENTS

10	11	12	13	14	15	16	17	18
+24 V	Y1	Y3	Y5	Y7	Y9	YB	YD	YF
1	2	3	4	5	6	7	8	9
0 V	Y0	Y2	Y4	Y6	Y8	YA	YC	YE

NO.	ID	FUNCTION	NO.	ID	FUNCTION
1	0 V	0 V (common)	10	+24 V	24 V DC
2	Y0	Output 0	11	Y1	Output 1
3	Y2	Output 2	12	Y3	Output 3
4	Y4	Output 4	13	Y5	Output 5
5	Y6	Output 6	14	Y7	Output 7
6	Y8	Output 8	15	Y9	Output 9
7	YA	Output 10	16	YB	Output 11
8	YC	Output 12	17	YD	Output 13
9	YE	Output 14	18	YF	Output 15

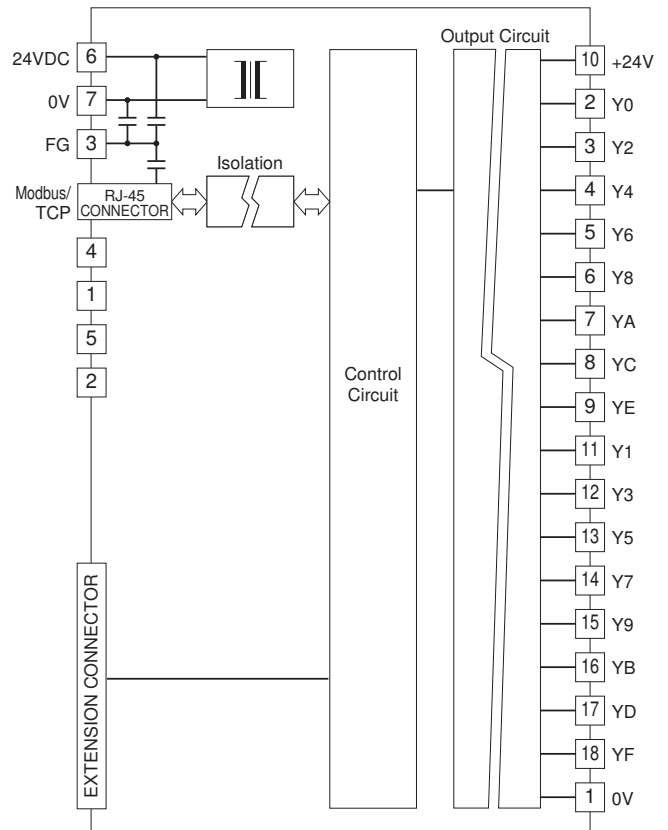

Output Circuit

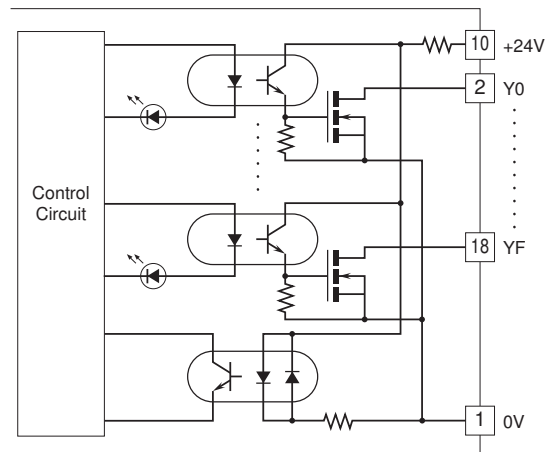

Output Connection Example

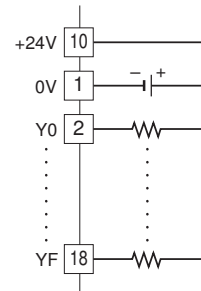

## PNP TRANSISTOR OUTPUT MODULE, 16 points

## CIRCUIT DIAGRAM

### MODEL: R7E-DC16B

### SPECIFICATIONS

- Common:** Positive common (PNP) per 16 points
- Number of I/O:** Output, 16 points
- Maximum outputs applicable at once:** No limit (at 24 V DC)
- Output status indicator LED:** Turns ON with contact ON
- Isolation:** Output to Ethernet to FG to power input
- Rated load voltage:** 24 V DC  $\pm 10\%$
- Rated output current:** 0.25 A per point, 2.0 A per common
- Residual voltage:**  $\leq 1.2$  V
- Leakage current:**  $\leq 0.1$  mA
- ON delay:**  $\leq 0.5$  msec.
- OFF delay:**  $\leq 1.5$  msec.

### OPERATING MODE SETTING

(\*) Factory setting

Caution ! - SW1-3, 1-5 through 1-8 are unused. Be sure to turn off unused ones.

#### • Output at the loss of communication (SW1-4)

SW1-4	OUTPUT AT THE LOSS OF COMMUNICATION
OFF	Reset the output (turned off)
ON	Hold the output (*) (maintains the last data received normally)

#### • Extension (SW1-1, 1-2)

SW1-1	SW1-2	EXTENSION
OFF	OFF	No extension (*)
ON	OFF	Discrete input, 8 or 16 points
OFF	ON	Discrete output, 8 or 16 points

### TERMINAL ASSIGNMENTS

10	11	12	13	14	15	16	17	18
+24 V	Y1	Y3	Y5	Y7	Y9	YB	YD	YF
1	2	3	4	5	6	7	8	9
0 V	Y0	Y2	Y4	Y6	Y8	YA	YC	YE

NO.	ID	FUNCTION	NO.	ID	FUNCTION
1	0 V	0 V	10	+24 V	24 V DC (common)
2	Y0	Output 0	11	Y1	Output 1
3	Y2	Output 2	12	Y3	Output 3
4	Y4	Output 4	13	Y5	Output 5
5	Y6	Output 6	14	Y7	Output 7
6	Y8	Output 8	15	Y9	Output 9
7	YA	Output 10	16	YB	Output 11
8	YC	Output 12	17	YD	Output 13
9	YE	Output 14	18	YF	Output 15

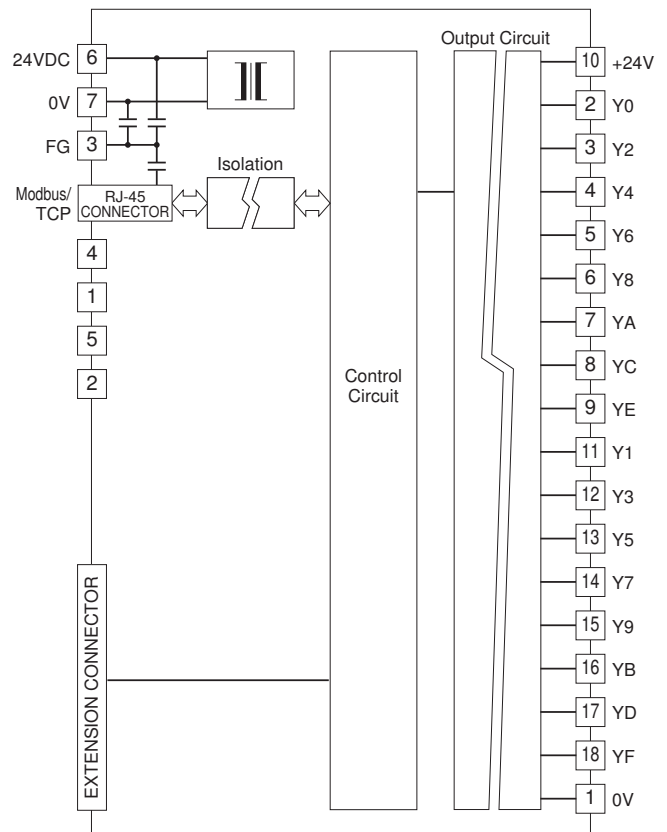

Output Circuit

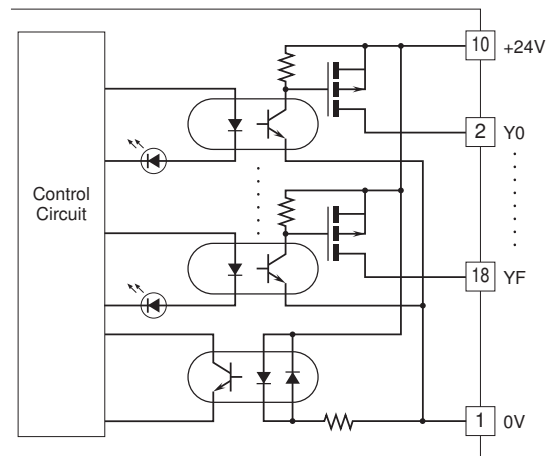

Output Connection Example

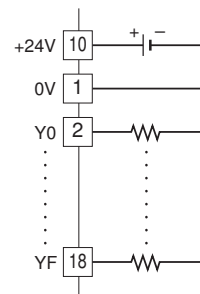

## DC VOLTAGE/CURRENT INPUT MODULE, 4 points

### MODEL: R7E-SV4

#### SPECIFICATIONS

**Isolation:** Input 0 to input 1 to input 2 to input 3 to Ethernet to FG to power input

**Converted data range:** 0 - 10000 of the input range

• **Input range**

**Wide span voltage:** -10 - +10 V DC, -5 - +5 V DC,  
0 - 10 V DC, 0 - 5 V DC, 1 - 5 V DC

**Narrow span voltage:** -1 - +1 V DC, 0 - 1 V DC,  
-0.5 - +0.5 V DC

**Current range:** -20 - +20 mA DC, 0 - 20 mA DC,  
4 - 20 mA DC

• **Input resistance**

**Wide span voltage:**  $\geq 1 \text{ M}\Omega$

**Narrow span voltage:**  $\geq 100 \text{ k}\Omega$

**Current range:**  $70 \Omega$

**Conversion rate / conversion accuracy:**

10 msec./ $\pm 0.8 \%$ , 20 msec./ $\pm 0.4 \%$ , 40 msec./ $\pm 0.2 \%$ ,  
80 msec./ $\pm 0.1 \%$

**Response time:** Conversion rate  $\times 2 + 50$  msec. (0 - 90 %)

**Temperature coefficient:**  $\pm 0.015 \%/^{\circ}\text{C}$  ( $\pm 0.008 \%/^{\circ}\text{F}$ )

#### OPERATING MODE SETTING

(\*) Factory setting

• **Input range (SW1-5, 1-6, 1-7, 1-8)**

SW1-5	SW1-6	SW1-7	SW1-8	INPUT RANGE
OFF	OFF	OFF	OFF	-10 - +10 V DC (*)
ON	OFF	OFF	OFF	-5 - +5 V DC
OFF	ON	OFF	OFF	-1 - +1 V DC
ON	ON	OFF	OFF	0 - 10 V DC
OFF	OFF	ON	OFF	0 - 5 V DC
ON	OFF	ON	OFF	1 - 5 V DC
OFF	ON	ON	OFF	0 - 1V DC
ON	ON	ON	OFF	-0.5 - +0.5 V DC
ON	OFF	OFF	ON	-20 - +20 mA DC
OFF	ON	OFF	ON	4 - 20 mA DC
ON	ON	OFF	ON	0 - 20 mA DC
ON	ON	ON	ON	PC Configurator setting

• **Conversion rate / Accuracy (SW1-3, 1-4)**

SW1-3	SW1-4	CONVERSION RATE / ACCURACY
OFF	OFF	80 msec. / $\pm 0.1\%$ (*)
ON	OFF	40 msec. / $\pm 0.2\%$
OFF	ON	20 msec. / $\pm 0.4\%$
ON	ON	10 msec. / $\pm 0.8\%$

• **Extension (SW1-1, 1-2)**

SW1-1	SW1-2	EXTENSION
OFF	OFF	No extension (*)
ON	OFF	Discrete input, 8 or 16 points
OFF	ON	Discrete output, 8 or 16 points

#### TERMINAL ASSIGNMENTS

10	11	12	13	14	15	16	17	18
VL0	I0	VL1	I1	NC	VL2	I2	VL3	I3
1	2	3	4	5	6	7	8	9
VH0	COM0	VH1	COM1	NC	VH2	COM2	VH3	COM3

NO.	ID	FUNCTION	NO.	ID	FUNCTION
1	VH0	Wide span volt. 0	10	VL0	Narrow span volt. 0
2	COM0	Common 0	11	I0	Current range 0
3	VH1	Wide span volt. 1	12	VL1	Narrow span volt. 1
4	COM1	Common 1	13	I1	Current range 1
5	NC	No connection	14	NC	No connection
6	VH2	Wide span volt. 2	15	VL2	Narrow span volt. 2
7	COM2	Common 2	16	I2	Current range 2
8	VH3	Wide span volt. 3	17	VL3	Narrow span volt. 3
9	COM3	Common 3	18	I3	Current range 3

#### CIRCUIT DIAGRAM

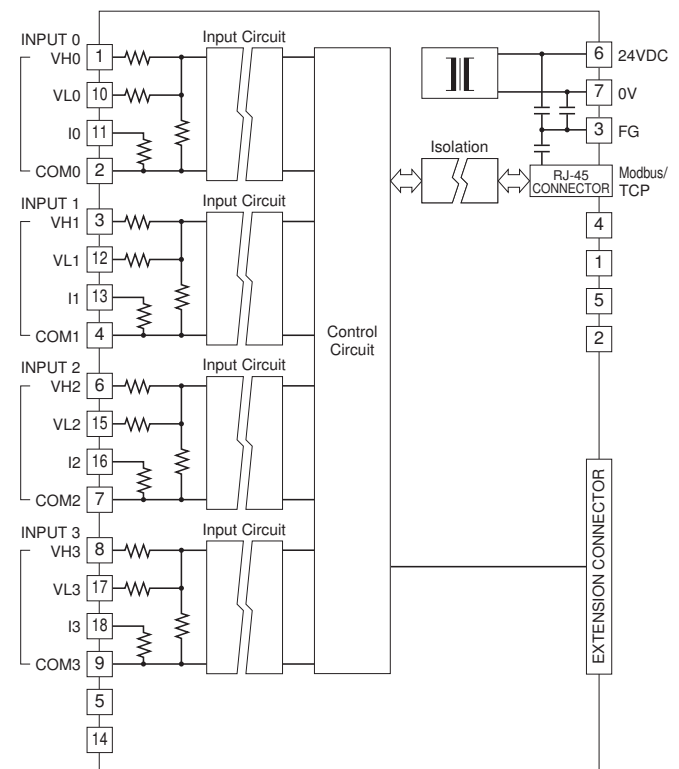

Input Connection Examples

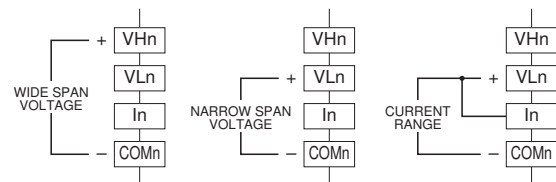

Be sure to close across VLn and In terminals for a current input.



## THERMOCOUPLE INPUT MODULE, 4 points

### MODEL: R7E-TS4

#### SPECIFICATIONS

**Isolation:** Input 0 to input 1 to input 2 to input 3 to Ethernet to FG to power input

**Converted data range:** Engineering unit value (°C, K) × 10 (integer); No multiplication for °F

**Thermocouple:** K, E, J, T, B, R, S, C, N, U, L, P, PR

**Input resistance:** ≥ 30 kΩ

**Burnout sensing:** ≤ 0.1 μA

**Conversion accuracy:** ±1°C (±1.8°F);

±2.0°C (±3.6°F) for B, R, S, C, PR

**Conversion rate:** 250 msec. or 1 sec.

**Response time:** Conversion rate × 2 + 50 msec. (0 - 90 %)

**Temperature coefficient:** ±0.015 %/°C (±0.008 %/°F)

**CJC error:** ±1.0°C at 25°C ±10°C

(±1.8°F at 77°F ±18°F)

±1.5°C (±2.7°F) for R, S, PR

T/C	BURNOUT INDICATION (°C)		CONFORMANCE RANGE (°C)
	Downscale	Upscale	
K (CA)	-272	+1472	-150 to +1370
E (CRC)	-272	+1120	-170 to +1000
J (IC)	-260	+1300	-180 to +1200
T (CC)	-272	+ 500	-170 to + 400
B (RH)	24	1920	400 to 1760
R	-100	+1860	200 to 1760
S	-100	+1860	0 to 1760
C (WRe 5-26)	-52	+2416	0 to 2315
N	-272	+1400	-130 to +1300
U	-252	+ 700	-200 to +600
L	-252	+1000	-200 to +900
P (Platinel II)	-52	+1496	0 to 1395
(PR)	-52	+1860	0 to 1760

T/C	BURNOUT INDICATION (°F)		CONFORMANCE RANGE (°F)
	Downscale	Upscale	
K (CA)	-458	+2682	-238 to +2498
E (CRC)	-458	+2048	-274 to +1832
J (IC)	-436	+2372	-292 to +2192
T (CC)	-458	+932	-274 to +752
B (RH)	75	3488	752 to 3200
R	-148	+3380	392 to 3200
S	-148	+3380	32 to 3200
C (WRe 5-26)	-62	+4381	32 to 4199
N	-458	+2552	-202 to +2372
U	-422	+1292	-328 to +1112
L	-422	+1832	-328 to +1652
P (Platinel II)	-62	+2725	32 to 2543
(PR)	-62	+3380	32 to 3200

#### OPERATING MODE SETTING

(\*) Factory setting

• Thermocouple type (SW1-5, 1-6, 1-7, 1-8)

SW1-5	SW1-6	SW1-7	SW1-8	THERMOCOUPLE TYPE
OFF	OFF	OFF	OFF	K (CA) (*)
ON	OFF	OFF	OFF	E (CRC)
OFF	ON	OFF	OFF	J (IC)
ON	ON	OFF	OFF	T (CC)
OFF	OFF	ON	OFF	B (RH)
ON	OFF	ON	OFF	R
OFF	ON	ON	OFF	S
ON	ON	ON	OFF	C (WRe 5-26)
OFF	OFF	OFF	ON	N
ON	OFF	OFF	ON	U
OFF	ON	OFF	ON	L
ON	ON	OFF	ON	P (Platinel II)
OFF	OFF	ON	ON	(PR)
ON	ON	ON	ON	PC Configurator setting

• Conversion rate (SW1-3)

SW1-3	CONVERSION RATE
OFF	250 msec. (*)
ON	1 sec.

• Burnout (SW1-4)

SW1-4	BURNOUT
OFF	Upscale (*)
ON	Downscale

• Extension (SW1-1, 1-2)

SW1-1	SW1-2	EXTENSION
OFF	OFF	No extension (*)
ON	OFF	Discrete input, 8 or 16 points
OFF	ON	Discrete output, 8 or 16 points

#### TERMINAL ASSIGNMENTS

10	11	12	13	14	15	16	17	18
+IN0	-IN0	+IN1	-IN1	NC	+IN2	-IN2	+IN3	-IN3
1	2	3	4	5	6	7	8	9
+CJ0	-CJ0	+CJ1	-CJ1	NC	+CJ2	-CJ2	+CJ3	-CJ3

NO.	ID	FUNCTION	NO.	ID	FUNCTION
1	+CJ0	CJC + 0	10	+IN0	T/C + 0
2	-CJ0	CJC - 0	11	-IN0	T/C - 0
3	+CJ1	CJC + 1	12	+IN1	T/C + 1
4	-CJ1	CJC - 1	13	-IN1	T/C - 1
5	NC	No connection	14	NC	No connection
6	+CJ2	CJC + 2	15	+IN2	T/C + 2
7	-CJ2	CJC - 2	16	-IN2	T/C - 2
8	+CJ3	CJC + 3	17	+IN3	T/C + 3
9	-CJ3	CJC - 3	18	-IN3	T/C - 3



**CIRCUIT DIAGRAM**

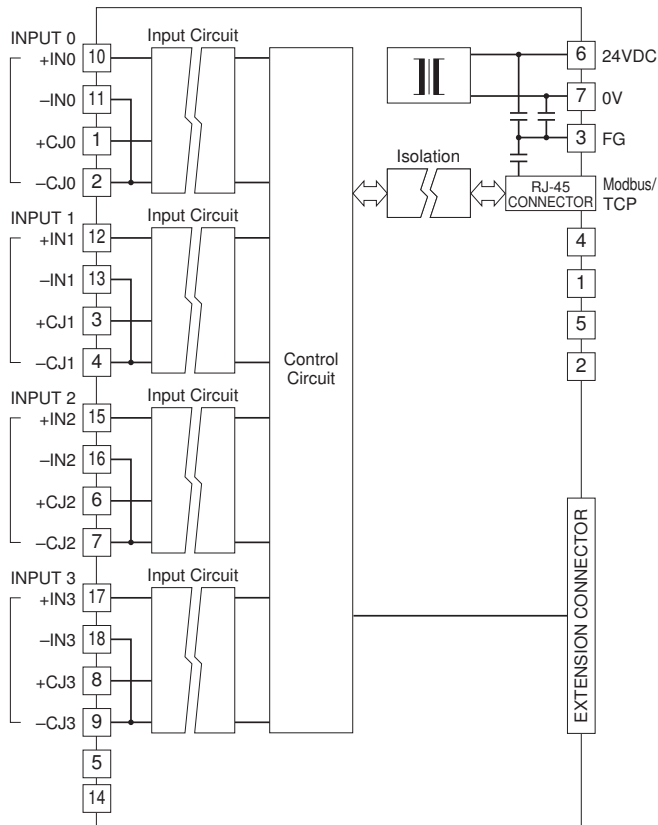

Input Connection Example

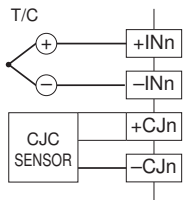



## RTD INPUT MODULE, 4 points

### MODEL: R7E-RS4

#### SPECIFICATIONS

**Isolation:** Input 0 to input 1 to input 2 to input 3 to Ethernet to FG to power input

**Converted data range:** Engineering unit value (°C, K) × 10 (integer); No multiplication for °F

**RTD:** Pt 100 (JIS '97, IEC), Pt 100 (JIS '89), JPt 100 (JIS '89), Pt 50 Ω (JIS '81), Ni 100, Cu 10, Cu 50

**Sensing current:** ≤ 1 mA

**Input resistance:** ≥ 1 MΩ

**Maximum leadwire resistance:** 100 Ω per wire

**Conversion accuracy:** ±1°C (±1.8°F);

±3°C (±5.4°F) for Cu 10

**Conversion rate:** 250 msec. or 1 sec.

**Response time:** Conversion rate × 2 + 50 msec. (0 - 90 %)

**Temperature coefficient:** ±0.015 %/°C (±0.008 %/°F)

RTD	BURNOUT INDICATION (°C)		CONFORMANCE RANGE (°C)
	Downscale	Upscale	
Pt 100 (JIS '97, IEC)	-240	+900	-200 to +850
Pt 100 (JIS '89)	-240	+900	-200 to +660
JPt 100 (JIS '89)	-236	+560	-200 to +510
Pt 50 Ω (JIS '81)	-236	+700	-200 to +649
Ni 100	-100	+252	-80 to +250
Cu 10 (25°C)	-212	+312	-50 to +250
Cu 50	-100	+200	-50 to +150

RTD	BURNOUT INDICATION (°F)		CONFORMANCE RANGE (°F)
	Downscale	Upscale	
Pt 100 (JIS '97, IEC)	-400	+1652	-328 to +1562
Pt 100 (JIS '89)	-400	+1652	-328 to +1220
JPt 100 (JIS '89)	-393	+1040	-328 to +950
Pt 50 Ω (JIS '81)	-393	+1292	-328 to +1200
Ni 100	-148	+486	-112 to +482
Cu 10 (25°C)	-350	+594	-58 to +482
Cu 50	-148	+392	-58 to +302

#### OPERATING MODE SETTING

(\*) Factory setting

• RTD type (SW1-5, 1-6, 1-7, 1-8)

SW1-5	SW1-6	SW1-7	SW1-8	RTD TYPE
OFF	OFF	OFF	OFF	Pt 100 (JIS '97, IEC) (*)
ON	OFF	OFF	OFF	Pt 100 (JIS '89)
OFF	ON	OFF	OFF	JPt 100 (JIS '89)
ON	ON	OFF	OFF	Pt 50 Ω (JIS '81)
OFF	OFF	ON	OFF	Ni 100
ON	OFF	ON	OFF	Cu 10 (25°C)
OFF	OFF	OFF	ON	Cu 50
ON	ON	ON	ON	PC Configurator setting

• Conversion rate (SW1-3)

SW1-3	CONVERSION RATE
OFF	250 msec. (*)
ON	1 sec.

• Burnout (SW1-4)

SW1-4	BURNOUT
OFF	Upscale (*)
ON	Downscale

• Extension (SW1-1, 1-2)

SW1-1	SW1-2	EXTENSION
OFF	OFF	No extension (*)
ON	OFF	Discrete input, 8 or 16 points
OFF	ON	Discrete output, 8 or 16 points

#### TERMINAL ASSIGNMENTS

10 INA0	11 INb0	12 INA1	13 INb1	14 NC	15 INA2	16 INb2	17 INA3	18 INb3
1 NC	2 INB0	3 NC	4 INB1	5 NC	6 NC	7 INB2	8 NC	9 INB3

NO.	ID	FUNCTION	NO.	ID	FUNCTION
1	NC	No connection	10	INA0	RTD 0-A
2	INB0	RTD 0-B	11	INb0	RTD 0-b
3	NC	No connection	12	INA1	RTD 1-A
4	INB1	RTD 1-B	13	INb1	RTD 1-b
5	NC	No connection	14	NC	No connection
6	NC	No connection	15	INA2	RTD 2-A
7	INB2	RTD 2-B	16	INb2	RTD 2-b
8	NC	No connection	17	INA3	RTD 3-A
9	INB3	RTD 3-B	18	INb3	RTD 3-b





**CIRCUIT DIAGRAM**

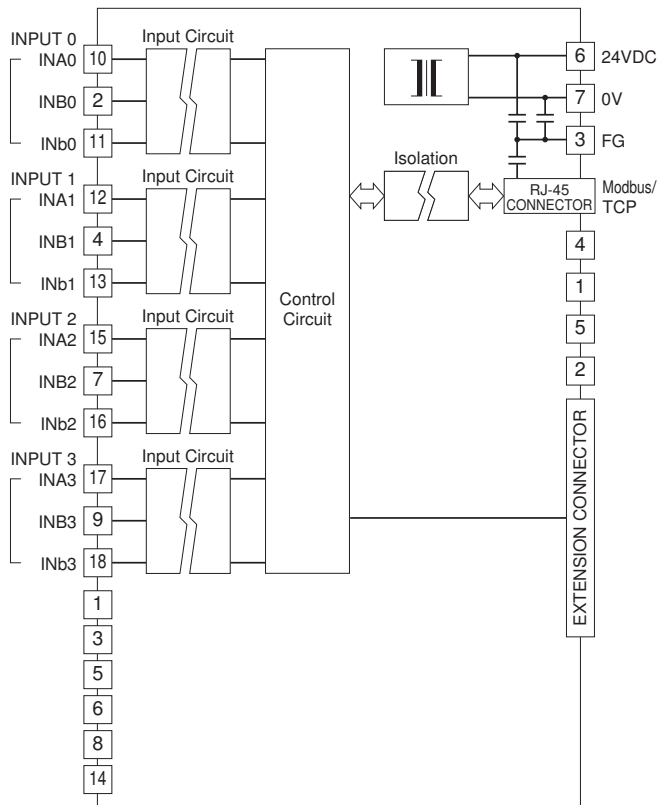

Input Connection Example

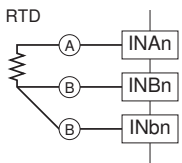

## POTENTIOMETER INPUT MODULE, 4 points

### MODEL: R7E-MS4

#### SPECIFICATIONS

**Isolation:** Input 0 to input 1 to input 2 to input 3 to Ethernet to FG to power input

**Converted data range:** 0 - 10000 of the input range

**Potentiometer:** Total resistance 100 Ω - 20 kΩ

**Minimum span:** 50 % of total resistance

**Excitation:** Approx. 0.2 V DC

**Conversion rate / conversion accuracy:**

10 msec./±0.8 %, 20 msec./±0.4 %, 40 msec./±0.2 %, 80 msec./±0.1 %

**Response time:** Conversion rate × 2 + 50 msec. (0 - 90 %)

**Temperature coefficient:** ±0.015 %/°C (±0.008 %/°F)

#### OPERATING MODE SETTING

(\*) Factory setting

Caution ! - SW1-5, 1-6, 1-7, 1-8 are unused. Be sure to turn off unused ones.

##### • Conversion rate / Accuracy (SW1-3, 1-4)

SW1-3	SW1-4	CONVERSION RATE / ACCURACY
OFF	OFF	80 msec. / ±0.1% (*)
ON	OFF	40 msec. / ±0.2%
OFF	ON	20 msec. / ±0.4%
ON	ON	10 msec. / ±0.8%

##### • Extension (SW1-1, 1-2)

SW1-1	SW1-2	EXTENSION
OFF	OFF	No extension (*)
ON	OFF	Discrete input, 8 or 16 points
OFF	ON	Discrete output, 8 or 16 points

#### TERMINAL ASSIGNMENTS

10	11	12	13	14	15	16	17	18
H0	S0	H1	S1	NC	H2	S2	H3	S3
1	2	3	4	5	6	7	8	9
NC	L0	NC	L1	NC	NC	L2	NC	L3

NO.	ID	FUNCTION	NO.	ID	FUNCTION
1	NC	No connection	10	H0	Pot H0
2	L0	Pot L0	11	S0	Pot S0
3	NC	No connection	12	H1	Pot H1
4	L1	Pot L1	13	S1	Pot S1
5	NC	No connection	14	NC	No connection
6	NC	No connection	15	H2	Pot H2
7	L2	Pot L2	16	S2	Pot S2
8	NC	No connection	17	H3	Pot H3
9	L3	Pot L3	18	S3	Pot S3

#### CIRCUIT DIAGRAM

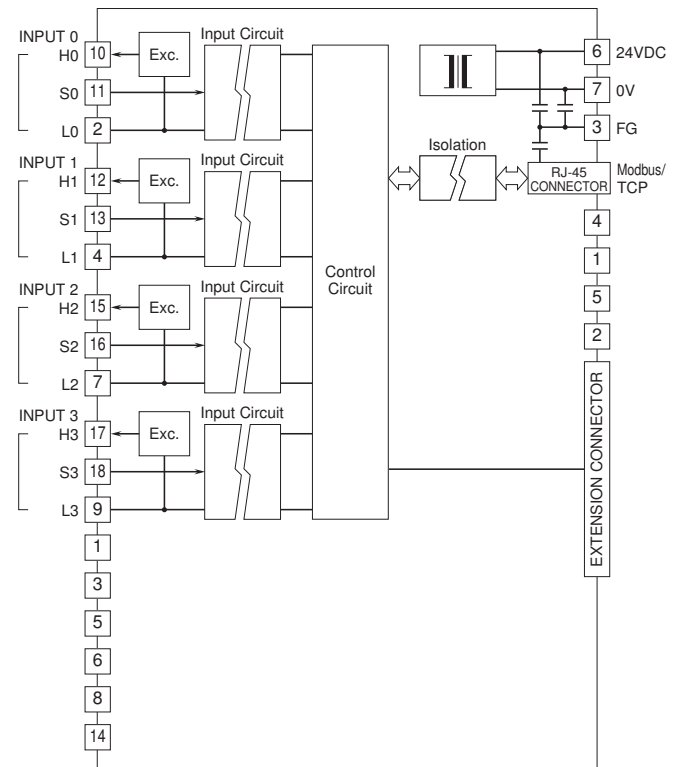

Input Connection Example

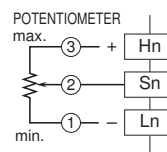

## AC CURRENT INPUT MODULE, 4 points

(clamp-on current sensor CLSE use)

### MODEL: R7E-CT4E

### SPECIFICATIONS

**Isolation:** Input 0 to input 1 to input 2 to input 3 to Ethernet to FG to power input

**Converted data range:**

Engineering unit value (A) × 100 (Integer)

(Engineering unit value (A) × 1000 (Integer) for CLSE-R5)

**Input range (Optional)**

CLSE-R5: 0 - 5 A AC

CLSE-05: 0 - 50 A AC

CLSE-10: 0 - 100 A AC

CLSE-20: 0 - 200 A AC

CLSE-40: 0 - 400 A AC

CLSE-60: 0 - 600 A AC

**Frequency:** 50/60 Hz

**Overload capacity:** 120 % continuous

**Operational range:** 5 - 115 % of rating

(Note: Use for the circuit not exceed 480 V)

**Conversion rate / conversion accuracy:**

10 msec./±2.0 %, 20 msec./±1.0 %, 40 msec./±0.5 %, 80 msec./±0.5 %

(The conversion accuracy does not include the accuracy of the sensor.)

**Response time:** ≤ 1.0 sec. (0 - 90 %)

**Temperature coefficient:** ±0.015 %/°C (±0.008 %/°F)

### OPERATING MODE SETTING

(\*) Factory setting

**• Input range (SW1-5, 1-6, 1-7, 1-8)**

SW1-5	SW1-6	SW1-7	SW1-8	INPUT RANGE
OFF	OFF	OFF	OFF	CLSE-60 (*)
ON	OFF	OFF	OFF	CLSE-40
OFF	ON	OFF	OFF	CLSE-20
ON	ON	OFF	OFF	CLSE-10
OFF	OFF	ON	OFF	CLSE-05
ON	OFF	ON	OFF	CLSE-R5
ON	ON	ON	ON	PC Configurator setting

**• Conversion rate / Accuracy (SW1-3, 1-4)**

SW1-3	SW1-4	CONVERSION RATE / ACCURACY
OFF	OFF	80 msec. / ±0.5% (*)
ON	OFF	40 msec. / ±0.5%
OFF	ON	20 msec. / ±1.0%
ON	ON	10 msec. / ±2.0%

**• Extension (SW1-1, 1-2)**

SW1-1	SW1-2	EXTENSION
OFF	OFF	No extension (*)
ON	OFF	Discrete input, 8 or 16 points
OFF	ON	Discrete output, 8 or 16 points

### TERMINAL ASSIGNMENTS

10	11	12	13	14	15	16	17	18
K0	L0	K1	L1	NC	K2	L2	K3	L3
1	2	3	4	5	6	7	8	9
NC	NC	NC	NC	NC	NC	NC	NC	NC

NO.	ID	FUNCTION	NO.	ID	FUNCTION
1	NC	No connection	10	K0	AC current K0
2	NC	No connection	11	L0	AC current L0
3	NC	No connection	12	K1	AC current K1
4	NC	No connection	13	L1	AC current L1
5	NC	No connection	14	NC	No connection
6	NC	No connection	15	K2	AC current K2
7	NC	No connection	16	L2	AC current L2
8	NC	No connection	17	K3	AC current K3
9	NC	No connection	18	L3	AC current L3

### CIRCUIT DIAGRAM

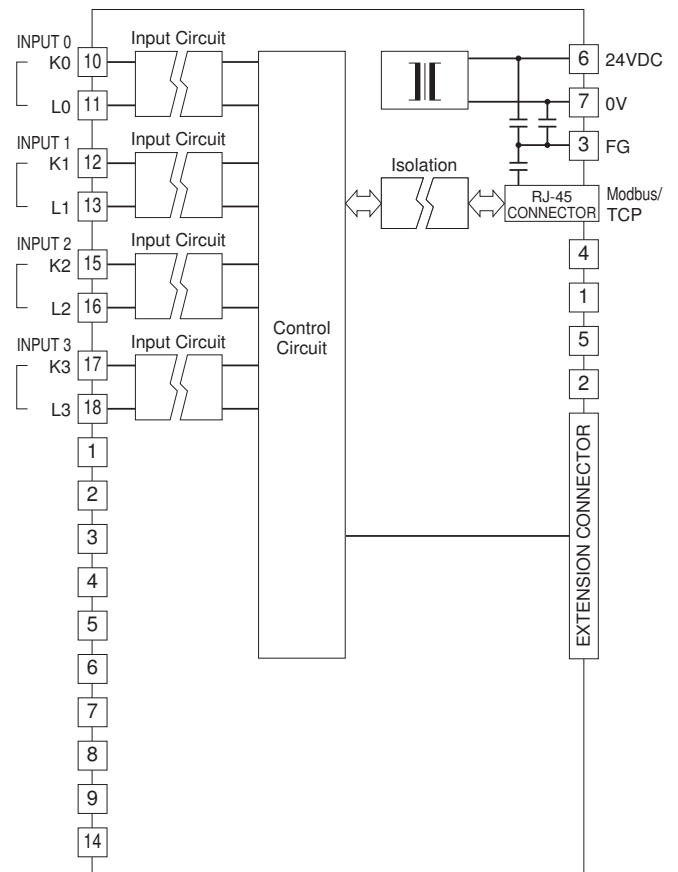

**Input Connection Example**

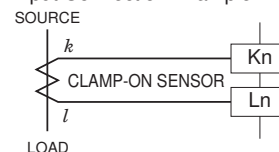

## DC VOLTAGE OUTPUT MODULE, 2 points

**MODEL: R7E-YV2**

### SPECIFICATIONS

**Isolation:** Output 0 to output 1 to Ethernet to FG to power input

**Converted data range:** 0 - 10000 of the output range

**Output range**

**Wide span voltage:** -10 - +10 V DC, -5 - +5 V DC, 0 - 10 V DC, 0 - 5 V DC, 1 - 5 V DC

**Narrow span voltage:** -1 - +1 V DC, 0 - 1 V DC, -0.5 - +0.5 V DC

**Operational range:** -15 - +115 % of the output range (except -10 - +10 V DC);

approx. -11.5 - +11.5 V DC (-10 - +10 V DC)

**Load resistance:**  $\geq 100 \text{ k}\Omega$

**Conversion accuracy:**  $\pm 0.1 \%$

**Response time:** 250 msec. (0 - 90 %)

**Temperature coefficient:**  $\pm 0.015 \%/^{\circ}\text{C}$  ( $\pm 0.008 \%/^{\circ}\text{F}$ )

### OPERATING MODE SETTING

(\*) Factory setting

Caution ! - SW1-3 is unused. Be sure to turn off unused ones.

#### • Output range (SW1-5, 1-6, 1-7, 1-8)

SW1-5	SW1-6	SW1-7	SW1-8	OUTPUT RANGE
OFF	OFF	OFF	OFF	-10 - +10 V DC (*)
ON	OFF	OFF	OFF	-5 - +5 V DC
OFF	ON	OFF	OFF	-1 - +1 V DC
ON	ON	OFF	OFF	0 - 10 V DC
OFF	OFF	ON	OFF	0 - 5 V DC
ON	OFF	ON	OFF	1 - 5 V DC
OFF	ON	ON	OFF	0 - 1 V DC
ON	ON	ON	OFF	-0.5 - +0.5 V DC
ON	ON	ON	ON	PC Configurator setting

#### • Output at the loss of communication (SW1-4)

SW1-4	OUTPUT AT THE LOSS OF COMMUNICATION
OFF	Reset the output (to -15% or approx. -11.5V DC)
ON	Hold the output (*) (maintains the last data received normally)

#### • Extension (SW1-1, 1-2)

SW1-1	SW1-2	EXTENSION
OFF	OFF	No extension (*)
ON	OFF	Discrete input, 8 or 16 points
OFF	ON	Discrete output, 8 or 16 points

### TERMINAL ASSIGNMENTS

6	7	8	9	10
NC	VH0	VL0	VH1	VL1
1	2	3	4	5
NC	COM0	COM0	COM1	COM1

NO.	ID	FUNCTION	NO.	ID	FUNCTION
1	NC	No connection	6	NC	No connection
2	COM0	Common 0	7	VH0	Wide span volt. 0
3	COM0	Common 0	8	VL0	Narrow span volt. 0
4	COM1	Common 1	9	VH1	Wide span volt. 1
5	COM1	Common 1	10	VL1	Narrow span volt. 1

### CIRCUIT DIAGRAM

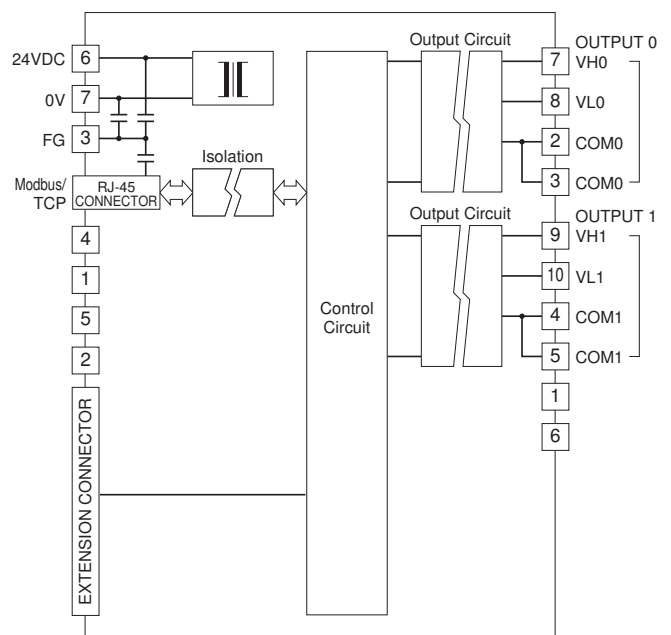

Output Connection Examples

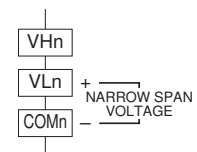
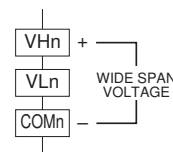

## DC CURRENT OUTPUT MODULE, 2 points

## CIRCUIT DIAGRAM

### MODEL: R7E-YS2

### SPECIFICATIONS

**Isolation:** Output 0 to output 1 to Ethernet to FG to power input

**Converted data range:** 0 - 10000 of the output range

**Output range:** 4 - 20 mA DC

**Load resistance:** ≤ 600Ω

**Conversion accuracy:** ±0.1 %

**Response time:** 250 msec. (0 - 90 %)

**Temperature coefficient:** ±0.015 %/°C (±0.008 %/°F)

### OPERATING MODE SETTING

(\*) Factory setting

Caution ! - SW1-3, 1-5 through 1-8 are unused. Be sure to turn off unused ones.

• **Output at the loss of communication (SW1-4)**

SW1-4	OUTPUT AT THE LOSS OF COMMUNICATION
OFF	Reset the output (to -15%)
ON	Hold the output (*) (maintains the last data received normally)

• **Extension (SW1-1, 1-2)**

SW1-1	SW1-2	EXTENSION
OFF	OFF	No extension (*)
ON	OFF	Discrete input, 8 or 16 points
OFF	ON	Discrete output, 8 or 16 points

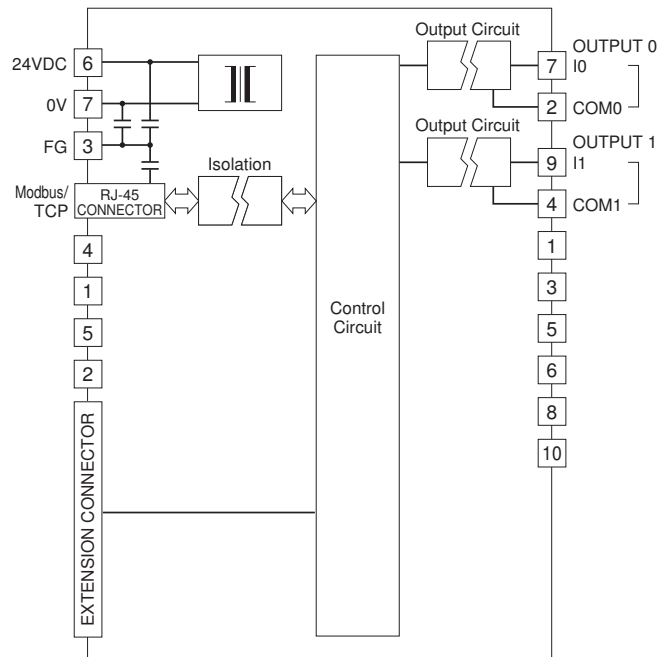

### TERMINAL ASSIGNMENTS

6	7	8	9	10
NC	I0	NC	I1	NC
1	2	3	4	5
NC	COM0	NC	COM1	NC

NO.	ID	FUNCTION	NO.	ID	FUNCTION
1	NC	No connection	6	NC	No connection
2	COM0	Common 0	7	I0	Current 0
3	NC	No connection	8	NC	No connection
4	COM1	Common 1	9	I1	Current 1
5	NC	No connection	10	NC	No connection



## DISCRETE INPUT EXTENSION MODULE, 8 points

## CIRCUIT DIAGRAM

### MODEL: R7E-EA8

### SPECIFICATIONS

**Common:** Positive or negative common (NPN/PNP) per 8 points

**Number of I/O:** Input, 8 points

**Maximum inputs applicable at once:** No limit (at 24 V DC)

**Input status indicator LED:** Turns ON with contact ON

**Isolation:** Input to internal circuits

**Rated input voltage:** 24 V DC  $\pm 10\%$ ; ripple 5 %p-p max.

**ON voltage / current:**  $\geq 15$  V DC (input - COM) /  $\geq 3.5$  mA

**OFF voltage / current:**  $\leq 5$  V DC (input - COM) /  $\leq 1$  mA

**Input current:**  $\leq 5.5$  mA per point at 24 V DC

**Input resistance:** Approx. 4.4 k $\Omega$

**ON delay:**  $\leq 2.0$  msec.

**OFF delay:**  $\leq 2.0$  msec.

### TERMINAL ASSIGNMENTS

6	7	8	9	10
NC	X1	X3	X5	X7
1	2	3	4	5
COM	X0	X2	X4	X6

NO.	ID	FUNCTION	NO.	ID	FUNCTION
1	COM	Common	6	NC	No Connection
2	X0	Input 0	7	X1	Input 1
3	X2	Input 2	8	X3	Input 3
4	X4	Input 4	9	X5	Input 5
5	X6	Input 6	10	X7	Input 7

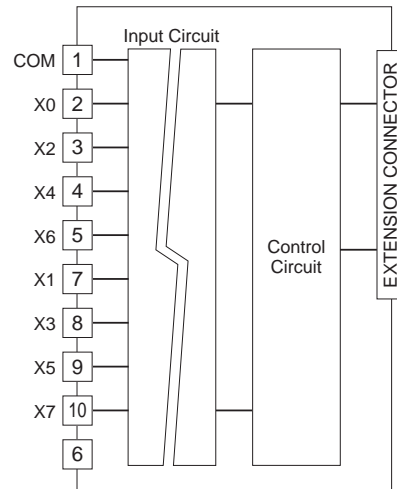

#### Input Circuit

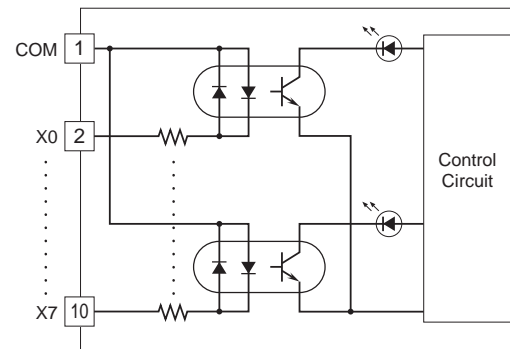

#### Input Connection Examples

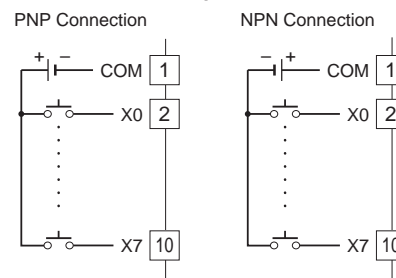

## DISCRETE INPUT EXTENSION MODULE, 16 points

## CIRCUIT DIAGRAM

### MODEL: R7E-EA16

### SPECIFICATIONS

- Common:** Positive or negative common (PNP/NPN) per 16 points
- Number of I/O:** Input, 16 points
- Maximum inputs applicable at once:** No limit (at 24 V DC)
- Input status indicator LED:** Turns ON with contact ON
- Isolation:** Input to internal circuits
- Rated input voltage:** 24 V DC  $\pm 10\%$ ; ripple 5 %p-p max.
- ON voltage / current:**  $\geq 15$  V DC (input - COM) /  $\geq 3.5$  mA
- OFF voltage / current:**  $\leq 5$  V DC (input - COM) /  $\leq 1$  mA
- Input current:**  $\leq 5.5$  mA per point at 24 V DC
- Input resistance:** Approx. 4.4 k $\Omega$
- ON delay:**  $\leq 2.0$  msec.
- OFF delay:**  $\leq 2.0$  msec.

### TERMINAL ASSIGNMENTS

10	11	12	13	14	15	16	17	18
NC	X1	X3	X5	X7	X9	XB	XD	XF
1	2	3	4	5	6	7	8	9
COM	X0	X2	X4	X6	X8	XA	XC	XE

NO.	ID	FUNCTION	NO.	ID	FUNCTION
1	COM	Common	10	NC	No Connection
2	X0	Input 0	11	X1	Input 1
3	X2	Input 2	12	X3	Input 3
4	X4	Input 4	13	X5	Input 5
5	X6	Input 6	14	X7	Input 7
6	X8	Input 8	15	X9	Input 9
7	XA	Input 10	16	XB	Input 11
8	XC	Input 12	17	XD	Input 13
9	XE	Input 14	18	XF	Input 15

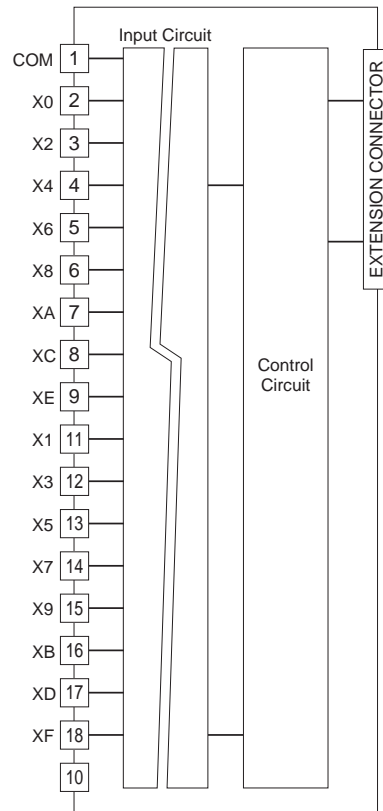

#### Input Circuit

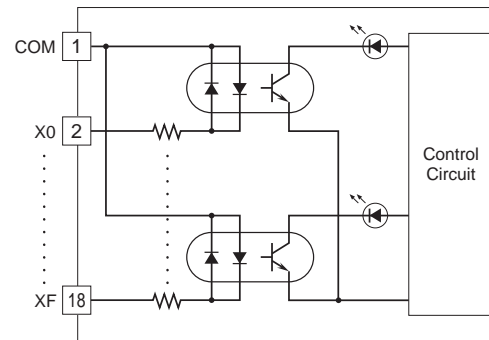

#### Input Connection Examples

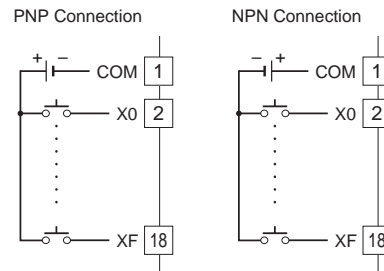

## NPN TRANSISTOR OUTPUT EXTENSION MODULE, 8 points

## CIRCUIT DIAGRAM

### MODEL: R7E-EC8A

### SPECIFICATIONS

- Common:** Negative common (NPN) per 8 points
- Number of I/O:** Output, 8 points
- Maximum outputs applicable at once:** No limit (at 24 V DC)
- Output status indicator LED:** Turns ON with contact ON
- Isolation:** Output to internal circuits
- Rated load voltage:** 24 V DC  $\pm 10\%$
- Rated output current:** 0.25 A per point, 2.0 A per common
- Residual voltage:**  $\leq 1.2$  V
- Leakage current:**  $\leq 0.1$  mA
- ON delay:**  $\leq 0.5$  msec.
- OFF delay:**  $\leq 1.5$  msec.

### TERMINAL ASSIGNMENTS

6	7	8	9	10
+24 V	Y1	Y3	Y5	Y7
1	2	3	4	5
0 V	Y0	Y2	Y4	Y6

NO.	ID	FUNCTION	NO.	ID	FUNCTION
1	0 V	0 V (common)	6	+24 V	24 V DC
2	Y0	Output 0	7	Y1	Output 1
3	Y2	Output 2	8	Y3	Output 3
4	Y4	Output 4	9	Y5	Output 5
5	Y6	Output 6	10	Y7	Output 7

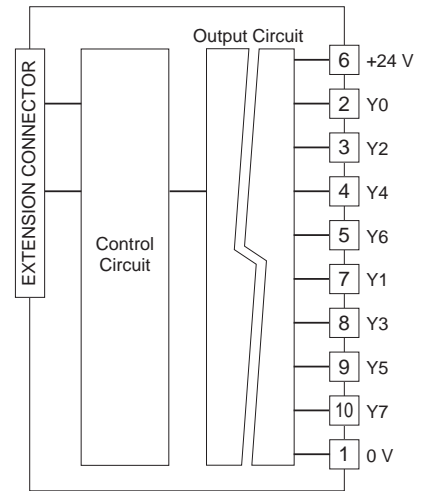

#### Output Circuit

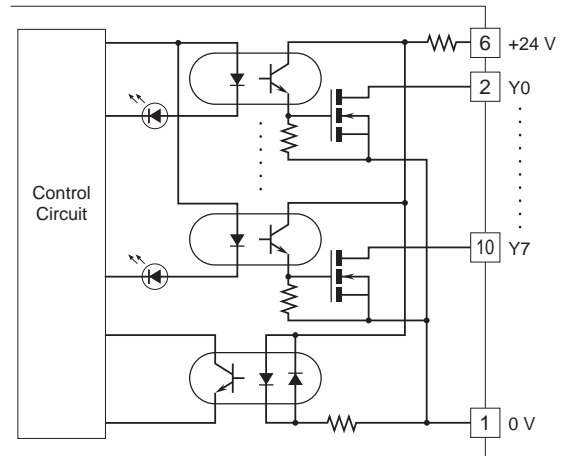

#### Output Connection Example

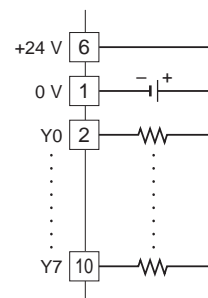



## NPN TRANSISTOR OUTPUT EXTENSION MODULE, 16 points

## CIRCUIT DIAGRAM

### MODEL: R7E-EC16A

#### SPECIFICATIONS

- Common:** Negative common (NPN) per 16 points
- Number of I/O:** Output, 16 points
- Maximum outputs applicable at once:** No limit (at 24 V DC)
- Output status indicator LED:** Turns ON with contact ON
- Isolation:** Output to internal circuits
- Rated load voltage:** 24 V DC  $\pm 10\%$
- Rated output current:** 0.25 A per point, 2.0 A per common
- Residual voltage:**  $\leq 1.2$  V
- Leakage current:**  $\leq 0.1$  mA
- ON delay:**  $\leq 0.5$  msec.
- OFF delay:**  $\leq 1.5$  msec.

#### TERMINAL ASSIGNMENTS

10	11	12	13	14	15	16	17	18
+24 V	Y1	Y3	Y5	Y7	Y9	YB	YD	YF
1	2	3	4	5	6	7	8	9
0 V	Y0	Y2	Y4	Y6	Y8	YA	YC	YE

NO.	ID	FUNCTION	NO.	ID	FUNCTION
1	0 V	0 V (common)	10	+24 V	24 V DC
2	Y0	Output 0	11	Y1	Output 1
3	Y2	Output 2	12	Y3	Output 3
4	Y4	Output 4	13	Y5	Output 5
5	Y6	Output 6	14	Y7	Output 7
6	Y8	Output 8	15	Y9	Output 9
7	YA	Output 10	16	YB	Output 11
8	YC	Output 12	17	YD	Output 13
9	YE	Output 14	18	YF	Output 15

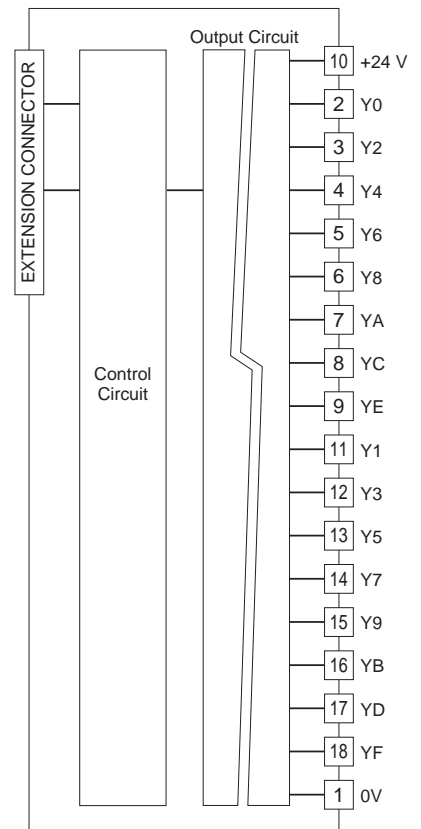

#### Output Circuit

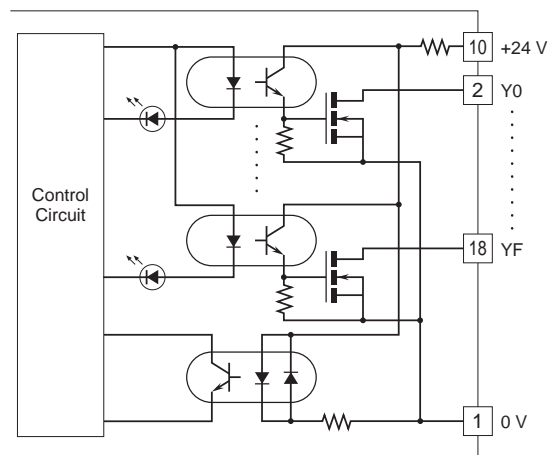

#### Output Connection Example

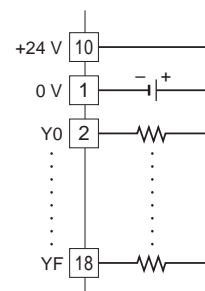

## PNP TRANSISTOR OUTPUT EXTENSION MODULE, 8 points

## CIRCUIT DIAGRAM

### MODEL: R7E-EC8B

### SPECIFICATIONS

- Common:** Positive common (PNP) per 8 points
- Number of I/O:** Output, 8 points
- Maximum outputs applicable at once:** No limit (at 24 V DC)
- Output status indicator LED:** Turns ON with contact ON
- Isolation:** Output to internal circuits
- Rated load voltage:** 24 V DC  $\pm 10\%$
- Rated output current:** 0.25 A per point, 2.0 A per common
- Residual voltage:**  $\leq 1.2$  V
- Leakage current:**  $\leq 0.1$  mA
- ON delay:**  $\leq 0.5$  msec.
- OFF delay:**  $\leq 1.5$  msec.

### TERMINAL ASSIGNMENTS

6	7	8	9	10
+24 V	Y1	Y3	Y5	Y7
1	2	3	4	5
0 V	Y0	Y2	Y4	Y6

NO.	ID	FUNCTION	NO.	ID	FUNCTION
1	0 V	0 V	6	+24 V	24 V DC (common)
2	Y0	Output 0	7	Y1	Output 1
3	Y2	Output 2	8	Y3	Output 3
4	Y4	Output 4	9	Y5	Output 5
5	Y6	Output 6	10	Y7	Output 7

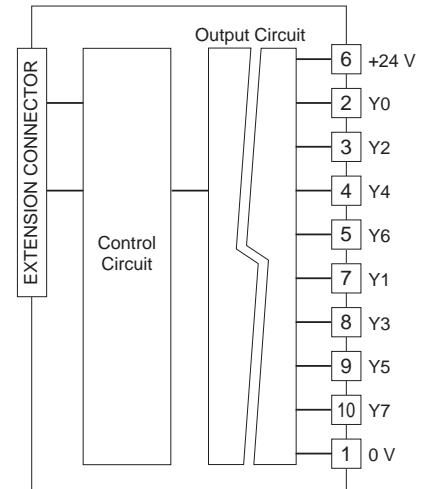

#### Output Circuit

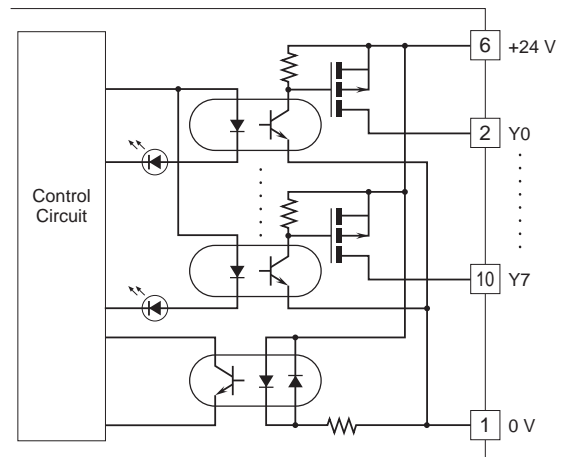

#### Output Connection Example

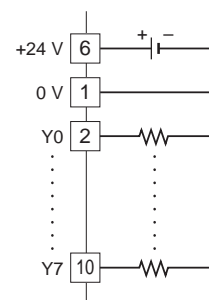

## PNP TRANSISTOR OUTPUT EXTENSION MODULE, 16 points

## CIRCUIT DIAGRAM

### MODEL: R7E-EC16B

#### SPECIFICATIONS

- Common:** Positive common (PNP) per 16 points
- Number of I/O:** Output, 16 points
- Maximum outputs applicable at once:** No limit (at 24 V DC)
- Output status indicator LED:** Turns ON with contact ON
- Isolation:** Output to internal circuits
- Rated load voltage:** 24 V DC  $\pm 10\%$
- Rated output current:** 0.25 A per point, 2.0 A per common
- Residual voltage:**  $\leq 1.2$  V
- Leakage current:**  $\leq 0.1$  mA
- ON delay:**  $\leq 0.5$  msec.
- OFF delay:**  $\leq 1.5$  msec.

#### TERMINAL ASSIGNMENTS

10	11	12	13	14	15	16	17	18
+24 V	Y1	Y3	Y5	Y7	Y9	YB	YD	YF
1	2	3	4	5	6	7	8	9
0 V	Y0	Y2	Y4	Y6	Y8	YA	YC	YE

NO.	ID	FUNCTION	NO.	ID	FUNCTION
1	0 V	0 V	10	+24 V	24 V DC (common)
2	Y0	Output 0	11	Y1	Output 1
3	Y2	Output 2	12	Y3	Output 3
4	Y4	Output 4	13	Y5	Output 5
5	Y6	Output 6	14	Y7	Output 7
6	Y8	Output 8	15	Y9	Output 9
7	YA	Output 10	16	YB	Output 11
8	YC	Output 12	17	YD	Output 13
9	YE	Output 14	18	YF	Output 15

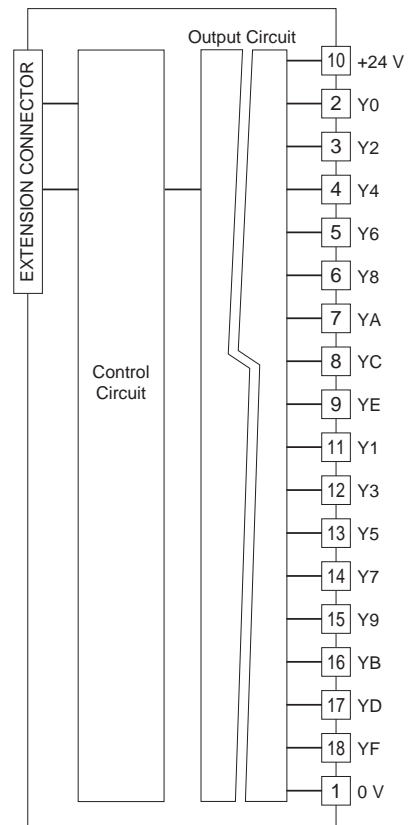

#### Output Circuit

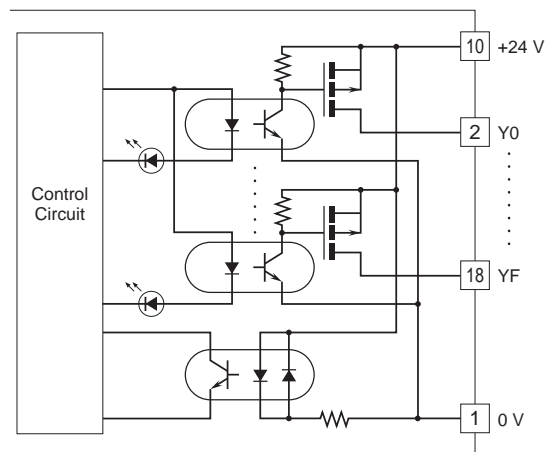

#### Output Connection Example

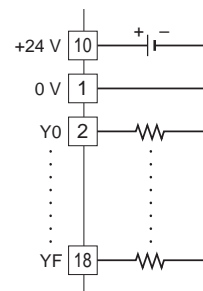



Specifications are subject to change without notice.

