

Remote I/O R7 Series

CC-Link I/O MODULE

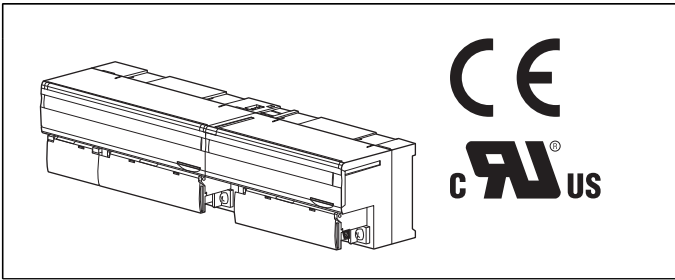

ORDERING INFORMATION

- Basic module: R7C-[1]-[2][3]
Specify a code from below for each [1] through [3].
(e.g. R7C-DC16A-R/UL)
If you need factory setting, use Ordering Information Sheet (No. ESU-7801-x).
- Extension module: R7C-[1][2]
Specify a code from below for each [1], [2].
(e.g. R7C-EC16A/UL)

BASIC MODULE: R7C-[1]-[2][3]

[1] I/O TYPE

- DA16:** Discrete input, 16 points
- DC16A:** NPN transistor output, 16 points
(Not usable with R7C-EA8 or R7C-EA16)
- DC16B:** PNP transistor output, 16 points
(Not usable with R7C-EA8 or R7C-EA16)
- DC8C:** Relay contact output, 8 points
(Option /UL Not selectable)
(Not usable with 'extension' modules)
- DC8E:** Relay contact output, 8 points
(CE not available. Option /UL Not selectable.)
(Not usable with R7C-EA8 or R7C-EA16)
(Terminating resistor incorporated)
- RR4:** Remote control relay control, 4 points
(CE not available. Option /UL Not selectable.)
(Not usable with 'extension' modules)
(Terminating resistor incorporated)
- SV4:** DC voltage/current input (10 V/20 mA), 4 points
- TS4:** Thermocouple input, 4 points
- RS4:** RTD input, 4 points
- RT4A:** Thermistor input, 4 points
(CE not available. Option /UL Not selectable.)
- MS4:** Potentiometer input, 4 points
(Option /UL Not selectable)
- CT4E:** AC current input, 4 points,

- Clamp-on current sensor CLSE use
(Option /UL Not selectable)
- PA8:** Totalized pulse input, 8 points,
(CE not available, option /UL not selectable)
- YV2:** DC voltage output, 2 points
- YS2:** DC current output, 2 points

[2] POWER INPUT

- DC Power**
- R: 24 V DC
- Universal**
- AR: 24 V AC/24 V DC (Only for R7C-RR4 and PA8)

[3] OPTIONS

- Standards & Approvals**
- blank: CE marking
- /UL: UL approval, CE marking

EXTENSION MODULE: R7C-[1][2]

[1] I/O TYPE

- EA8:** Discrete input, 8 points
- EA16:** Discrete input, 16 points
- EC8A:** NPN transistor output, 8 points
- EC16A:** NPN transistor output, 16 points
- EC8B:** PNP transistor output, 8 points
- EC16B:** PNP transistor output, 16 points
- EC8C:** Relay contact output, 8 points
(CE not available. Option /UL Not selectable.)

[2] OPTIONS

- STANDARDS & APPROVALS**
- blank: CE marking
- /UL: UL approval, CE marking

FUNCTIONS & FEATURES

The R7C interfaces analog and discrete I/O signals with a PLC via CC-Link.

A 'basic' module can be attached with an 'extension' module. (Exceptions: refer to the I/O type specifications) By combining two modules, single station can handle mixed analog and discrete signals, 32-point discrete inputs, 32-point discrete outputs, 16-point discrete I/Os and other combinations of signals. Only the combination of basic discrete output and extension discrete input modules is not available.

Input sensor type (thermocouple, RTD) and range can be selected with the front DIP switches for all channels. In order to set different selections for individual channels, zero/span adjustments, scaling and temperature unit, use



the PC Configurator Software (model: R7CON)

RELATED PRODUCTS

- PC configurator software (model: R7CON)
Downloadable at M-System's web site.
A dedicated cable is required to connect the module to the PC. Please refer to the internet software download site or the users manual for the PC configurator for applicable cable types.

PACKAGE INCLUDES...

- Terminating resistor (110 Ω, 0.25 W)
(Not provided for models terminating resistor incorporated)

GENERAL SPECIFICATIONS

- **Common Specifications**
Power input: 24 V DC ±10 %
Insulation resistance: ≥ 100 MΩ with 500 V DC
Dielectric strength: 1500 V AC @1 minute
(between isolated circuits)
Operating temperature: -10 to +55°C (14 to 131°F)
Operating humidity: 30 to 90 %RH (non-condensing)
Atmosphere: No corrosive gas or heavy dust
Storage temperature: -20 to +65°C (-4 to +149°F)
Mounting: DIN rail (35 mm wide)
Connection: M3 screw terminals (torque 0.5 N·m)
Screw terminal material: Nickel-plated steel
Recommended solderless terminal: Refer to the drawing at the end of the section.
Applicable wire size 0.3 to 0.75 mm²
Status indicator LED: PWR (Refer to the instruction manual for details)

■ Current Consumption (at 24 V DC) & Weight

- R7C-DA16: Approx. 60 mA, 200 g (0.44 lb)
- R7C-DC16A: Approx. 75 mA, 200 g (0.44 lb)
- R7C-DC16B: Approx. 75 mA, 200 g (0.44 lb)
- R7C-DC8C: Approx. 60 mA (approx. 60 mA), 200 g (0.44 lb)
- R7C-DC8E: Approx. 60 mA (approx. 60 mA), 200 g (0.44 lb)
- R7C-RR4: Approx. 65 mA, 170 g (0.37 lb)
- R7C-SV4: Approx. 90 mA, 200 g (0.44 lb)
- R7C-TS4: Approx. 90 mA, 200 g (0.44 lb)
- R7C-RS4: Approx. 90 mA, 200 g (0.44 lb)
- R7C-RT4A: Approx. 95 mA, 200 g (0.44 lb)
- R7C-MS4: Approx. 110 mA, 200 g (0.44 lb)
- R7C-CT4E: Approx. 140 mA, 200 g (0.44 lb)
- R7C-PA8: Approx. 70 mA, 200 g (0.44 lb)
- R7C-YV2: Approx. 140 mA, 180 g (0.40 lb)
- R7C-YS2: Approx. 140 mA, 180 g (0.40 lb)
- R7C-EA8: Approx. 10 mA, 90 g (0.20 lb)
- R7C-EA16: Approx. 20 mA, 150 g (0.33 lb)
- R7C-EC8A: Approx. 10 mA, 90 g (0.20 lb)

- R7C-EC16A: Approx. 20 mA, 150 g (0.33 lb)
 - R7C-EC8B: Approx. 10 mA, 90 g (0.20 lb)
 - R7C-EC16B: Approx. 20 mA, 150 g (0.33 lb)
 - R7C-EC8C: Approx. 40 mA, 150 g (0.33 lb)
- The consumed current of supply power for the output is shown in ().

• Current Consumption (at 24 V AC)

- R7C-RR4: Approx. 100 mA
- R7C-PA8: Approx. 130 mA

• Station Type

- R7C-DA16: Remote I/O
- R7C-DC16A: Remote I/O
- R7C-DC16B: Remote I/O
- R7C-DC8C: Remote I/O
- R7C-DC8E: Remote I/O
- R7C-RR4: Remote I/O
- R7C-SV4: Remote device
- R7C-TS4: Remote device
- R7C-RS4: Remote device
- R7C-RT4A: Remote device
- R7C-MS4: Remote device
- R7C-CT4E: Remote device
- R7C-PA8: Remote device
- R7C-YV2: Remote device
- R7C-YS2: Remote device

■ Recommended solderless terminal (unit: mm(inch))

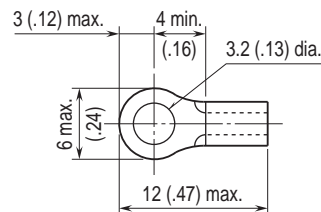

CC-Link COMMUNICATION

CC-Link Ver.1.10

Network cable: CC-Link cable designated by Mitsubishi Electric

Station number: 1 - 64 (rotary switch)

Baud rate setting: With rotary switch (156 kbps, 625 kbps, 2.5 Mbps, 5 Mbps, 10 Mbps)

Status indicator LEDs: RUN, ERR, SD, RD

STANDARDS & APPROVALS

CE conformity:

EMC Directive (2004/108/EC)

EMI EN 61000-6-4: 2007

EMS EN 61000-6-2: 2005

Low Voltage Directive (2006/95/EC)

(Only R7C-DC8C conforms to it. Refer to the instruction manual for the detailed information.)

EN 61010-1: 2001



幸託有限公司
XIN TOP CORPORATION

TEL : (02)2598-1199

FAX : (02)2596-2331

E-mail : info@xintop.com

Website : www.xintop.com

Measurement Category II
 Pollution Degree 2
 Output to power: Basic insulation (300 V)

Approval:

UL/C-UL nonincendive Class I, Division 2,
 Groups A, B, C, and D
 (ANSI/ISA-12.12.01:2007, CAN/CSA-C22.2 No.213:1987)
 UL/C-UL general safety requirements
 (UL 61010-1:2004, CAN/CSA-C22.2 No.61010-1:2004)

EXTERNAL VIEW

■ SIDE VIEW

■ FRONT VIEW

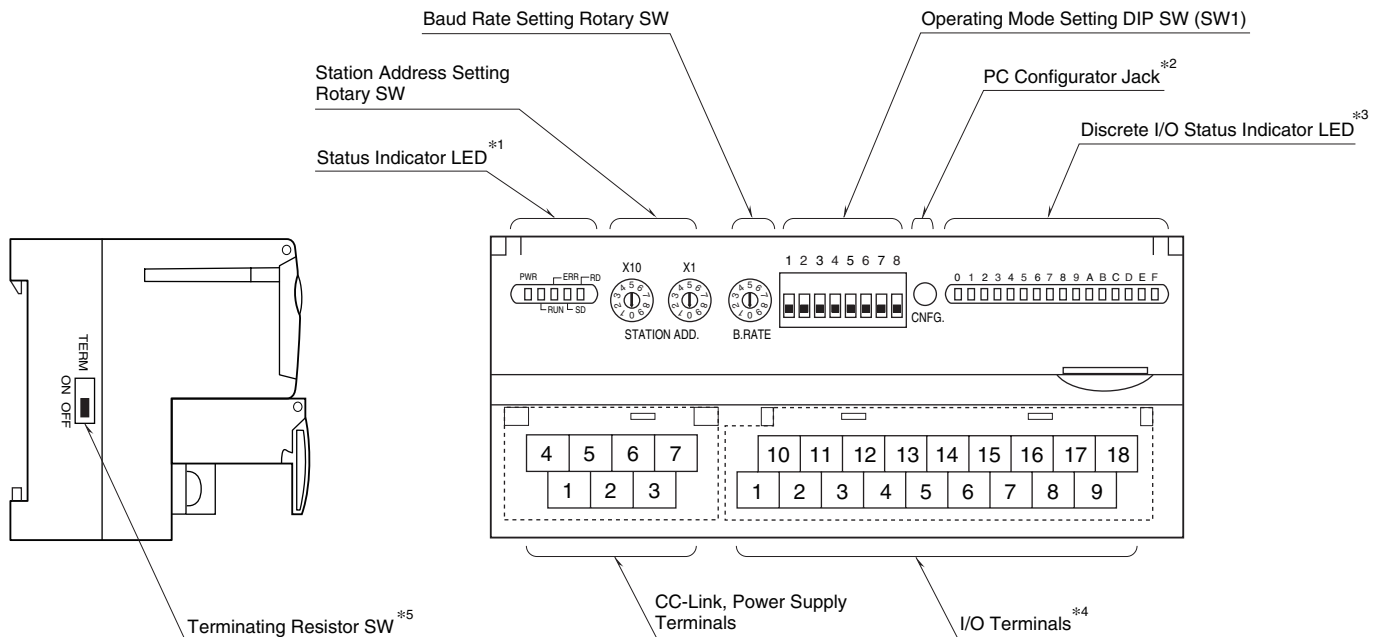

- *1. Refer to 'Status Indicator LED' section for detailed information.
- *2. Not available with discrete I/O modules.
- *3. Not available with analog I/O modules.
- *4. 10 screw terminals for analog output modules.
- *5. Only for R7C-DC8E, RR4 and PA8.

CONNECTION DIAGRAMS

■ POWER SUPPLY, CC-LINK TERMINAL ASSIGNMENT

Except R7C-RR4 and PA8

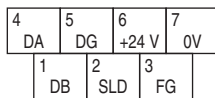

R7C-RR4 and PA8

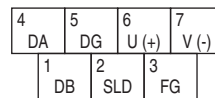

NO.	ID	FUNCTION, NOTES
1	DB	White
2	SLD	Shield
3	FG	FG
4	DA	Blue
5	DG	Yellow
6	+24 V	Power input (24 V DC)
7	0 V	Power input (0 V DC)

NO.	ID	FUNCTION, NOTES
1	DB	White
2	SLD	Shield
3	FG	FG
4	DA	Blue
5	DG	Yellow
6	U (+)	Power input
7	V (-)	Power input



■ MASTER CONNECTION

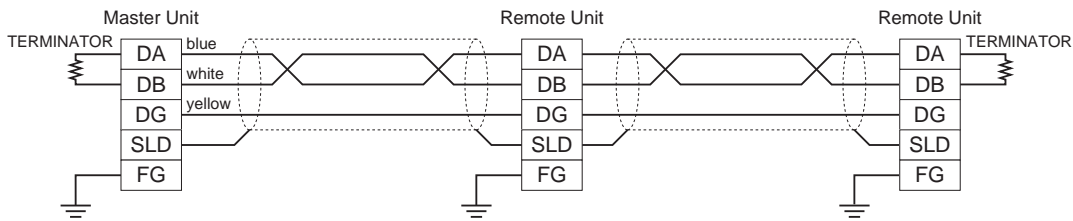

Be sure to connect the terminating resistor included in the product package to the unit at both ends of transmission line.
 Or turn the terminating resistor SW ON for models with the resistor incorporated.
 The terminator must be connected across DA and DB.
 The Master Unit can be located other than at the extreme ends of transmission line.

INDICATOR LED

■ STATUS INDICATOR LED

PWR	RUN	ERR	SD	RD	STATUS
ON	ON	BL	BL	ON	Communicates normally with occasional CRC errors due to noise interference.
ON	ON	BL	BL	ON	Communicates normally but the Baud Rate and/or Station Address switches failed. ERR LED flashes approximately in 0.5 second intervals.
ON	ON	BL	BL	OFF	----
ON	ON	BL	OFF	ON	CRC error found in the received data. Unable to respond.
ON	ON	BL	OFF	OFF	----
ON	ON	OFF	BL	ON	Normal communication
ON	ON	OFF	BL	OFF	----
ON	ON	OFF	OFF	ON	Unable to receive data addressed to the station.
ON	ON	OFF	OFF	OFF	----
ON	OFF	BL	BL	ON	Performs the interval-timed responses but CRC error found in receiving the refresh data.
ON	OFF	BL	BL	OFF	----
ON	OFF	BL	OFF	ON	CRC error found in the data addressed to the station.
ON	OFF	BL	OFF	OFF	----
ON	OFF	OFF	BL	ON	Link is not started.
ON	OFF	OFF	BL	OFF	----
ON	OFF	OFF	OFF	ON	No data addressed to the station. Or unable to receive data addressed to the station due to noise interference. (Missing parts of the data sent from the master)
ON	OFF	OFF	OFF	OFF	Unable to receive data due to wire breakdown
ON	OFF	ON	OFF	ON/OFF	Faulty Baud Rate and/or Station Address setting
OFF	OFF	OFF	OFF	OFF	Power input removed. Or power supply failure.

OFF = OFF, ON = ON, BL = Blinking

---- = Inconceivable in normal operations (e.g. LED failure)

■ DISCRETE I/O STATUS INDICATOR LED

Discrete I/O modules, including those for extensions, have LED indicators showing I/O signal status.

Totalized pulse modules have LED indicators showing input signal status.

Contact ON : LED ON

Contact OFF : LED OFF



DATA CONVERSION

■ 0 – 100% DATA CONVERSION

Analog input data is converted into digital representations of 0 – 100% proportional to each scaled range. The converted % values are multiplied by 100 and expressed in 16 bits.

Overrange input is possible from -15 to +115% of the nominal range. When the signal exceeds the limit, the data is fixed at -15% or +115% respectively. Negative value is represented in 2's complements.

• Input Range 0 – 5 V DC

Input Value	Input %	Converted Data, Decimal	Converted Data, Hex
≤ -0.75 V	-15%	-1500	FA24
0 V	0%	0	0
5 V	100%	10000	2710
≥ 5.75 V	115%	11500	2CEC

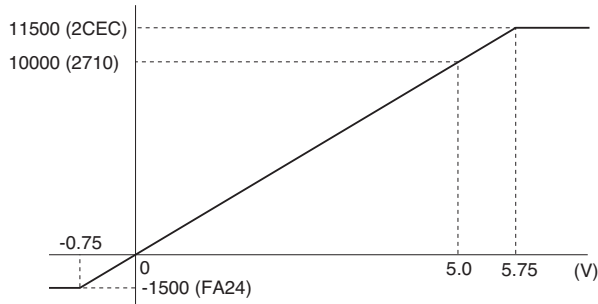

Analog output is converted in the reverse order of the input data. The output range 0 – 5 V DC is expressed as 10000 at 5.0 V (100%) and 0 at 0 V (0%).

■ ENGINEERING UNIT CONVERSION

Engineering unit value °C or K is multiplied by 10 and expressed in 16 bits. °F data is represented in engineering unit value, without multiplication. Engineering unit value A is multiplied by 100 or 1000, expressed in 16 bits. Negative value is represented in 2's complements.

• Input TYPE K Thermocouple

Input Value	Converted Data, Decimal	Converted Data, Hex
≤ -272°C	-2720	F560
-150°C	-1500	FA24
1370°C	13700	3584
≥ 1472°C	14720	3980

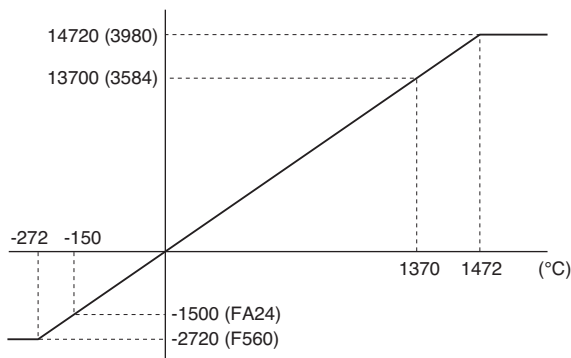

■ COUNT VALUE

The count value is 32-bit data. It is divided in 2 words of 16 bits represented with 2 addresses. The lower address is allocated in the lower word (LSB) and the upper address in the upper word (MSB). The count value is 0 - 4 294 967 295. The maximum count value available is 1 000 - 4 294 967 295. In case of overflow, the value is reset to 0 or 1 (configurable) from which the count will restart. The preset of the count value is also available. Use the R7CON or commands for the configuration.



DATA ALLOCATION

■ R7C-DA16

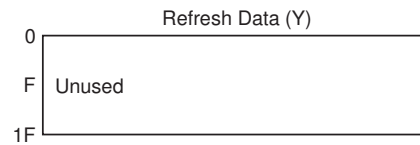
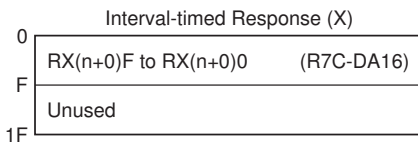

■ R7C-DA16 + R7C-EA16

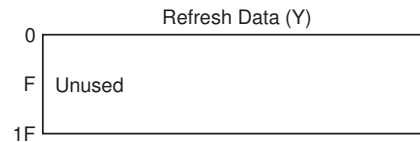
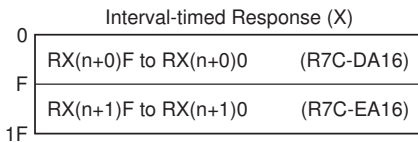

■ R7C-DA16 + R7C-EC16x

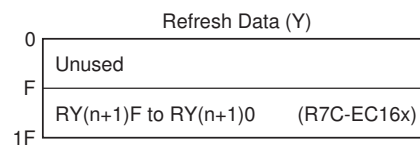
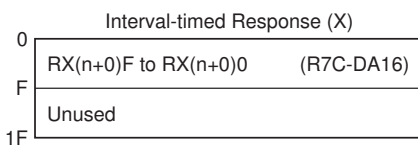

■ R7C-DC16x

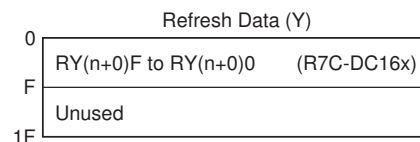
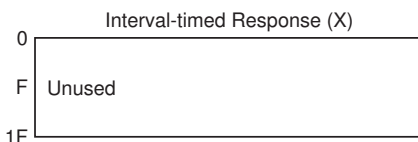

■ R7C-DC16x + R7C-EC16x

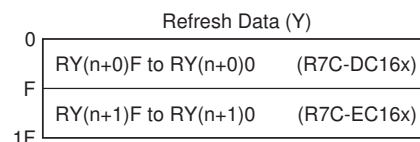
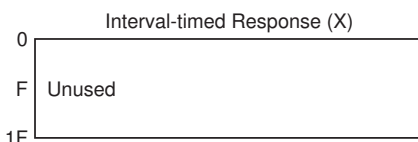

■ R7C-DC8x

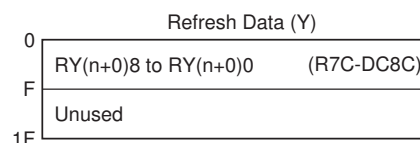
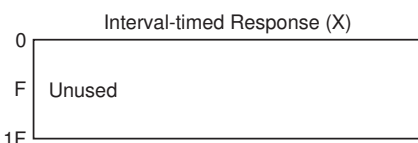

■ R7C-DC8E + R7C-EC16x

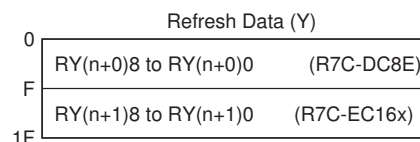
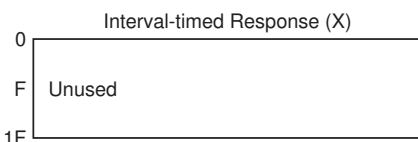

■ R7C-RR4

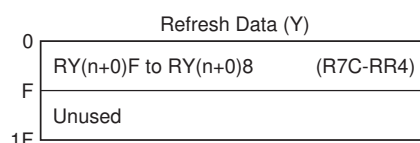
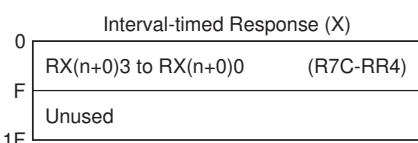

■ R7C-PA8

• Data allocation 1

Interval timed Response (X)	
RX (n+0)	RX (n+0) D – RX (n+0) 0: Command
RX (n+1)	Unused

Refresh Data (Y)	
RY (n+0)	RY (n+0) A – RY (n+0) 0: Command
RY (n+1)	Unused

Interval-timed Response (X)	
RWr (n+0)	Input extension
RWr (n+1)	Unused
RWr (n+2)	Count data (LSB)
RWr (n+3)	Count data (MSB)

Refresh Data (Y)	
RWw (n+0)	Output extension
RWw (n+1)	Unused
RWw (n+2)	Preset data (LSB)
RWw (n+3)	Preset data (MSB)

• Data allocation 4

Interval-timed Response (X)	
RX (n+0)	RX (n+0) D – RX (n+0) 0: Command
RX (n+1)	Input extension

Refresh Data (Y)	
RY (n+0)	RY (n+0)A – RY (n+0) 0: Command
RY (n+1)	Output extension

Interval-timed Response (X)	
RWr (n+0)	ch0 Count data (LSB)
RWr (n+1)	ch0 Count data (MSB)
RWr (n+2)	ch1 Count data (LSB)
RWr (n+3)	ch1 Count data (MSB)
RWr (n+4)	ch2 Count data (LSB)
RWr (n+5)	ch2 Count data (MSB)
RWr (n+6)	ch3 Count data (LSB)
RWr (n+7)	ch3 Count data (MSB)
RWr (n+8)	ch4 Count data (LSB)
RWr (n+9)	ch4 Count data (MSB)
RWr (n+10)	ch5 Count data (LSB)
RWr (n+11)	ch5 Count data (MSB)
RWr (n+12)	ch6 Count data (LSB)
RWr (n+13)	ch6 Count data (MSB)
RWr (n+14)	ch7 Count data (LSB)
RWr (n+15)	ch7 Count data (MSB)

Refresh Data (Y)	
RWw (n+0)	ch0 Preset data (LSB)
RWw (n+1)	ch0 Preset data (MSB)
RWw (n+2)	ch1 Preset data (LSB)
RWw (n+3)	ch1 Preset data (MSB)
RWw (n+4)	ch2 Preset data (LSB)
RWw (n+5)	ch2 Preset data (MSB)
RWw (n+6)	ch3 Preset data (LSB)
RWw (n+7)	ch3 Preset data (MSB)
RWw (n+8)	ch4 Preset data (LSB)
RWw (n+9)	ch4 Preset data (MSB)
RWw (n+10)	ch5 Preset data (LSB)
RWw (n+11)	ch5 Preset data (MSB)
RWw (n+12)	ch6 Preset data (LSB)
RWw (n+13)	ch6 Preset data (MSB)
RWw (n+14)	ch7 Preset data (LSB)
RWw (n+15)	ch7 Preset data (MSB)



■ ANALOG INPUT, 4 POINTS

■ Models R7C-SV4, R7C-TS4, R7C-RS4, R7C-RT4A, R7C-MS4, R7C-CT4E

Interval-timed Response (X)	
RWrn+0	Analog input 0
+1	Analog input 1
+2	Analog input 2
+3	Analog input 3

Refresh Data (Y)	
RWwn+0	Unused
+1	Unused
+2	Unused
+3	Unused

■ Without Extension Module

Interval-timed Response (X)	
0	RX(n+0)F to RX(n+0)0 (Status)
F	Reserved
1F	

Refresh Data (Y)	
0	
F	Unused
1F	

■ With Extension Module R7C-EA16

Interval-timed Response (X)	
0	RX(n+0)F to RX(n+0)0 (R7C-EA16)
F	Reserved
1F	

Refresh Data (Y)	
0	
F	Unused
1F	

■ With Extension Module R7C-EC16x

Interval-timed Response (X)	
0	RX(n+0)F to RX(n+0)0 (Status)
F	Reserved
1F	

Refresh Data (Y)	
0	RY(n+0)F to RY(n+0)0 (R7C-EC16x)
F	Unused
1F	

■ ANALOG OUTPUT, 2 POINTS

■ Models R7C-YV2, R7C-YS2

Interval-timed Response (X)	
RWrn+0	Unused
+1	Unused
+2	Unused
+3	Unused

Refresh Data (Y)	
RWwn+0	Analog output 0
+1	Analog output 1
+2	Unused
+3	Unused

■ Without Extension Module

Interval-timed Response (X)	
0	Unused
F	Reserved
1F	

Refresh Data (Y)	
0	
F	Unused
1F	

■ With Extension Module R7C-EA16

Interval-timed Response (X)	
0	RX(n+0)F to RX(n+0)0 (R7C-EA16)
F	Reserved
1F	

Refresh Data (Y)	
0	
F	Unused
1F	

■ With Extension Module R7C-EC16x

Interval-timed Response (X)	
0	Unused
F	Reserved
1F	

Refresh Data (Y)	
0	RY(n+0)F to RY(n+0)0 (R7C-EC16x)
F	Unused
1F	



I/O DATA DESCRIPTIONS

■ DISCRETE I/O

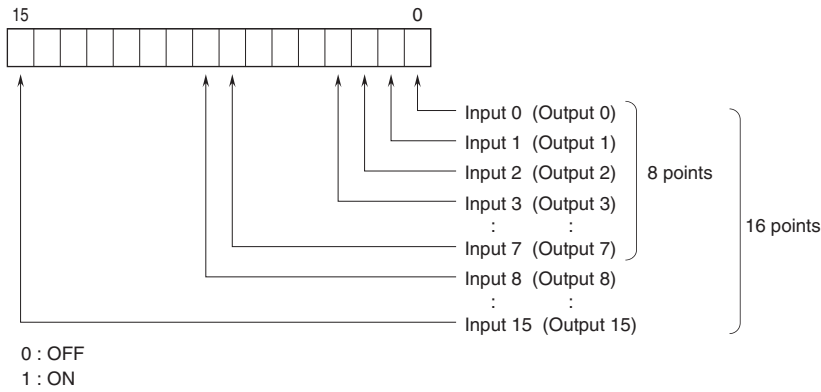

■ R7C-RR4

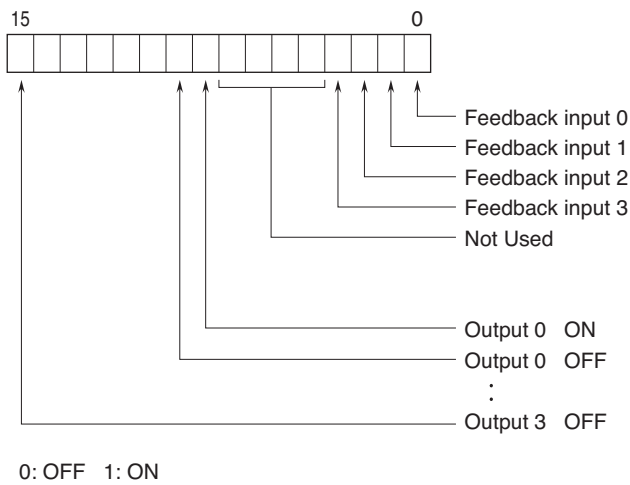

■ R7C-PA8

• RX (n+0)

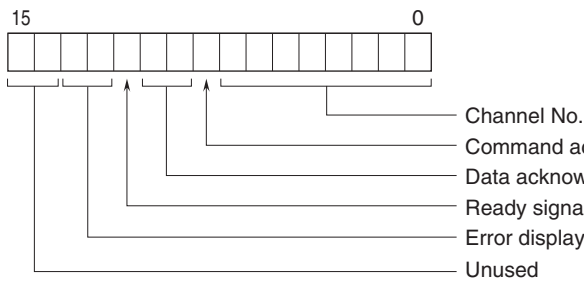

• RY (n+0)

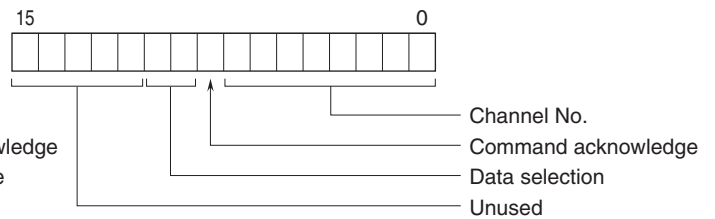

■ ANALOG I/O

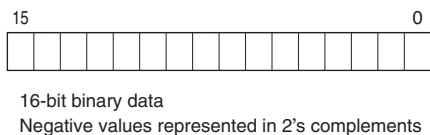

■ STATUS

Analog input modules (models: R7C-SV4, R7C-TS4, R7C-RS4, R7C-RT4A, R7C-MS4, R7C-CT4E) without extension module can show input status of each channel. 0 for Discrete Input/Output Module (R7C-DA16, R7C-DCx, RR4)

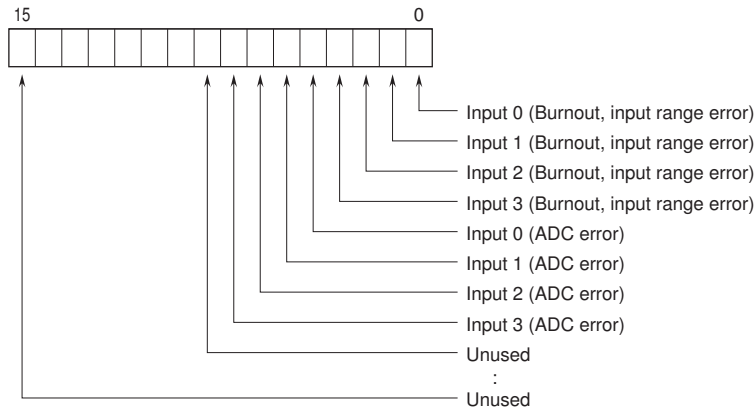

Burnout, input range error ($\leq -15\%$, $\geq +115\%$)

0 : Normal 1 : Error

ADC error (no response from ADC)

0 : Normal 1 : Error

EXTENSION MODULE

A 'basic' module can be attached with one 'extension' module. The extension module is powered from the basic module. By combining two modules, single station can handle mixed analog and discrete signals, 32-point discrete inputs, 32-point discrete outputs, 16-point discrete I/Os and other combinations of signals.

■ MODULE COMBINATIONS

(Basic module: Extension modules)

R7C-DA16: R7C-EA8, R7C-EA16, R7C-EC8A, R7C-EC16A, R7C-EC8B, R7C-EC16B, R7C-EC8C

R7C-DC16A*¹: R7C-EC8A, R7C-EC16A, R7C-EC8B, R7C-EC16B, R7C-EC8C

R7C-DC16B*¹: R7C-EC8A, R7C-EC16A, R7C-EC8B, R7C-EC16B, R7C-EC8C

R7C-DC8C*²: ----

R7C-DC8E*¹: R7C-EC8A, R7C-EC16A, R7C-EC8B, R7C-EC16B, R7C-EC8C

R7C-RR4*²: ----

R7C-SV4: R7C-EA8, R7C-EA16, R7C-EC8A, R7C-EC16A, R7C-EC8B, R7C-EC16B, R7C-EC8C

R7C-TS4: R7C-EA8, R7C-EA16, R7C-EC8A, R7C-EC16A, R7C-EC8B, R7C-EC16B, R7C-EC8C

R7C-RS4: R7C-EA8, R7C-EA16, R7C-EC8A, R7C-EC16A, R7C-EC8B, R7C-EC16B, R7C-EC8C

R7C-MS4: R7C-EA8, R7C-EA16, R7C-EC8A, R7C-EC16A, R7C-EC8B, R7C-EC16B, R7C-EC8C

R7C-CT4E: R7C-EA8, R7C-EA16, R7C-EC8A, R7C-EC16A, R7C-EC8B, R7C-EC16B, R7C-EC8C

R7C-PA8: R7C-EA8, R7C-EA16, R7C-EC8A, R7C-EC16A, R7C-EC8B, R7C-EC16B, R7C-EC8C

R7C-YV2: R7C-EA8, R7C-EA16, R7C-EC8A, R7C-EC16A, R7C-EC8B, R7C-EC16B, R7C-EC8C

R7C-YS2: R7C-EA8, R7C-EA16, R7C-EC8A, R7C-EC16A, R7C-EC8B, R7C-EC16B, R7C-EC8C

*1. Not usable with R7C-EA8 or R7C-EA16.

*2. Not usable with 'Extension' modules.

■ OUTPUT AT THE LOSS OF COMMUNICATION

• When the extension module is connected to the R7C-DA16 or the R7C-DC16x

The extension module is set to 'Reset Output' or 'Hold Output' according to the setting of SW1-5 of the module.

• When the extension module is connected to a module other than the R7C-DA16 or the R7C-DC16x

The extension module is set to 'Hold Output' by factory default setting. The PC Configurator is used to change the setting to 'Reset Output.'



■ CONNECTING THE EXTENSION MODULE

- 1) Remove the extension connector cover located at the side of the basic module.
- 2) Connect the extension module.

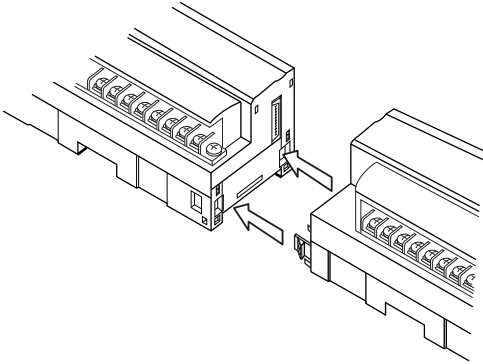

- 3) Mount the combined module on a DIN rail.

DIMENSIONS unit: mm (inch)

■ BASIC MODULE

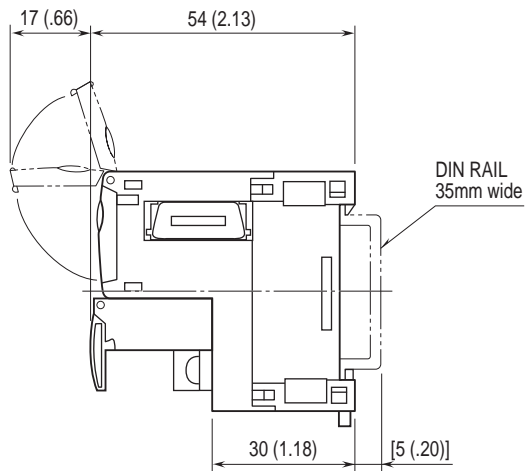
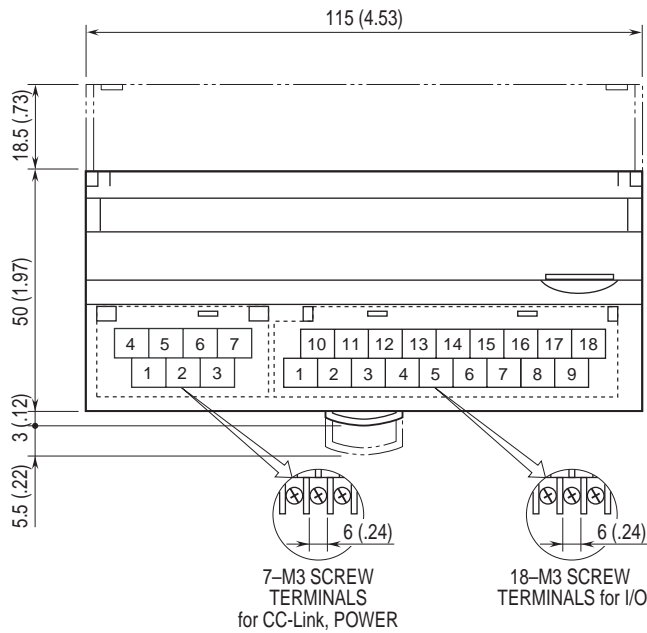

• R7C-TS4

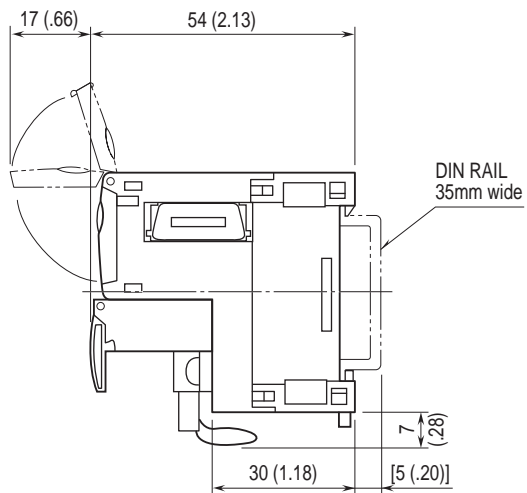

■ BASIC MODULE, ANALOG OUTPUT, R7C-RR4

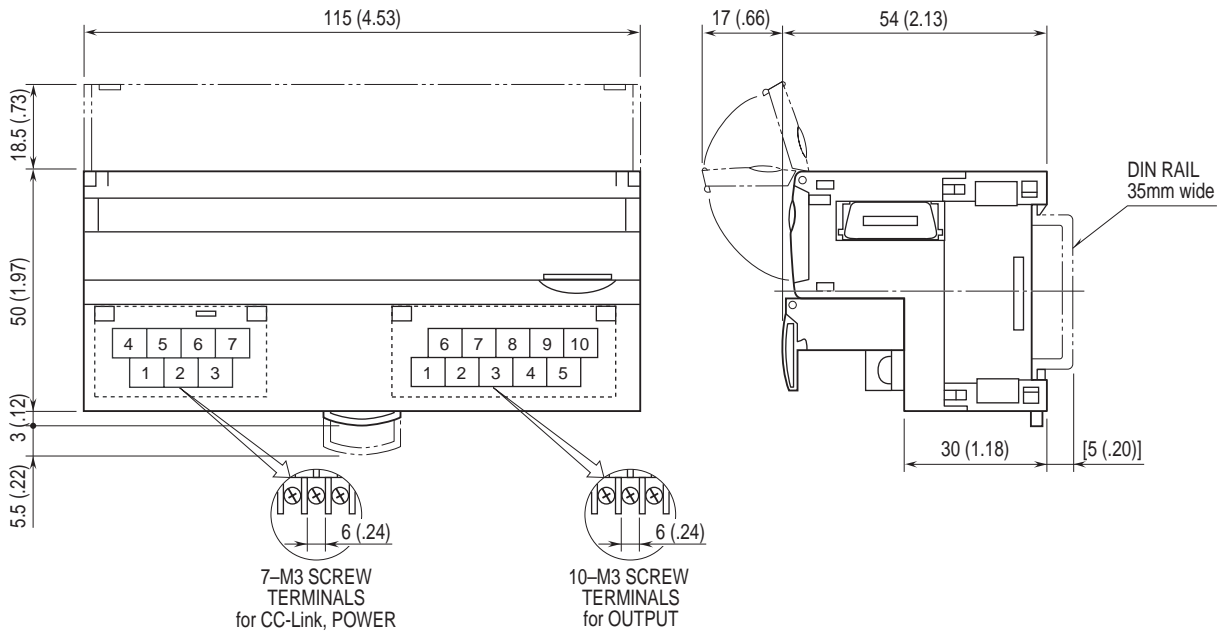

■ EXTENSION MODULE (R7C-EA8, R7C-EC8A, R7C-EC8B)

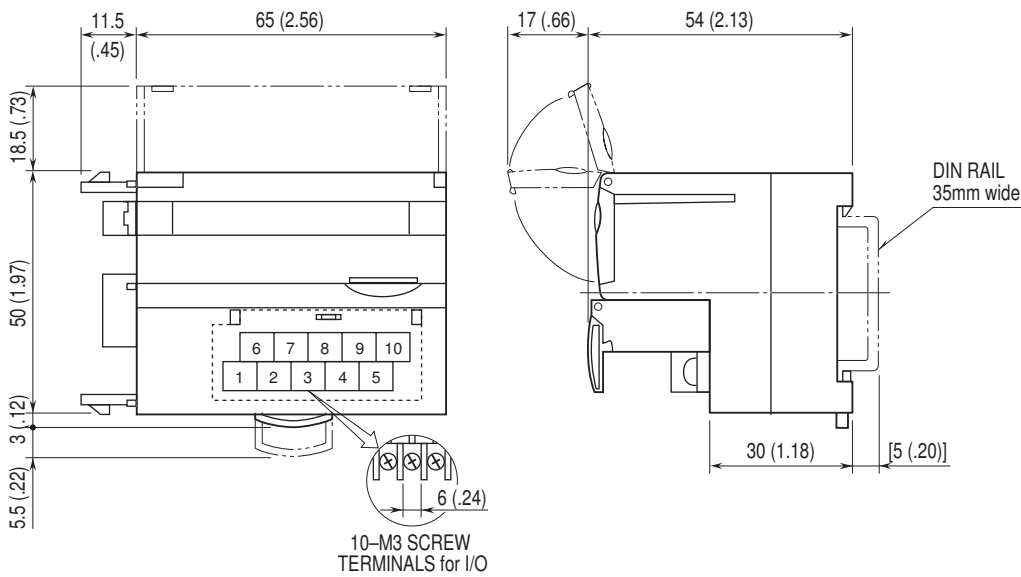

■ EXTENSION MODULE (R7C-EA16, R7C-EC16A, R7C-EC16B, R7C-EC8C)

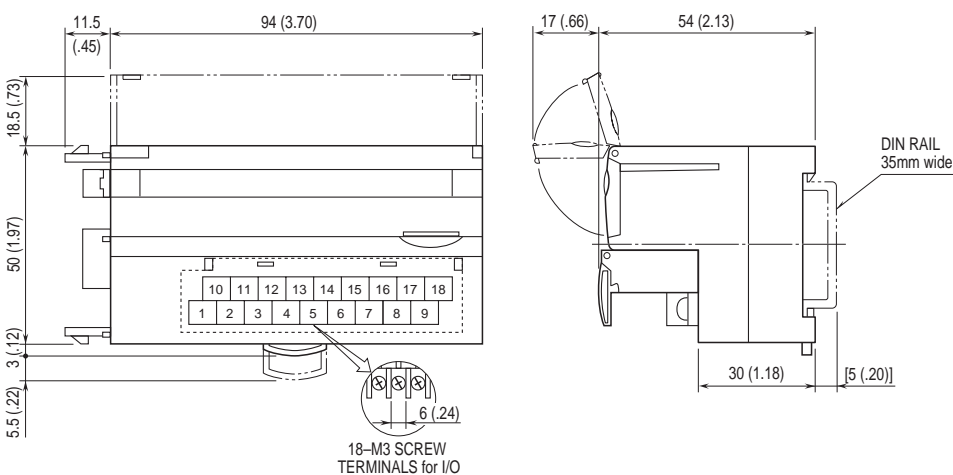

DISCRETE INPUT MODULE, 16 points

MODEL: R7C-DA16

SPECIFICATIONS

Common: Positive or negative common (NPN/PNP) per 16 points

Number of I/O: Input, 16 points

Maximum inputs applicable at once: No limit (at 24 V DC)

I/O status indicator: LED turns on with closed contact.

Isolation: Input to power input to CC-Link or FG

CC-Link: Conforms to Version 1.10

Station type: Remote I/O

Data allocation: 1

Rated input voltage: 24 V DC $\pm 10\%$; ripple 5 %p-p max.

ON voltage / current: ≥ 15 V DC (input - COM) / ≥ 3.5 mA

OFF voltage / current: ≤ 5 V DC (input - COM) / ≤ 1 mA

Input current: ≤ 5.5 mA per point at 24 V DC

Input resistance: Approx. 4.4 k Ω

ON delay: ≤ 2.0 msec.

OFF delay: ≤ 2.0 msec.

OPERATING MODE SETTING

(*) Factory setting

Caution ! - SW1-6, 1-7, 1-8 are unused. Be sure to turn off unused ones.

• Output at the loss of communication (SW1-5)

SW1-5	OUTPUT AT THE LOSS OF COMMUNICATION
OFF	Reset the output (turned off)
ON	Hold the output (*) (maintains the last data received normally)

• Extension (SW1-1, 1-2, 1-3, 1-4)

SW1-1	SW1-2	SW1-3	SW1-4	EXTENSION
ON	OFF	OFF	OFF	No extension (*)
ON	OFF	OFF	ON	Discrete input, 8 or 16 points
OFF	OFF	OFF	ON	Discrete output, 8 or 16 points

TERMINAL ASSIGNMENTS

10	11	12	13	14	15	16	17	18
COM	X1	X3	X5	X7	X9	XB	XD	XF
1	2	3	4	5	6	7	8	9
COM	X0	X2	X4	X6	X8	XA	XC	XE

NO.	ID	FUNCTION	NO.	ID	FUNCTION
1	COM	Common	10	COM	Common
2	X0	Input 0	11	X1	Input 1
3	X2	Input 2	12	X3	Input 3
4	X4	Input 4	13	X5	Input 5
5	X6	Input 6	14	X7	Input 7
6	X8	Input 8	15	X9	Input 9
7	XA	Input 10	16	XB	Input 11
8	XC	Input 12	17	XD	Input 13
9	XE	Input 14	18	XF	Input 15



CIRCUIT DIAGRAM

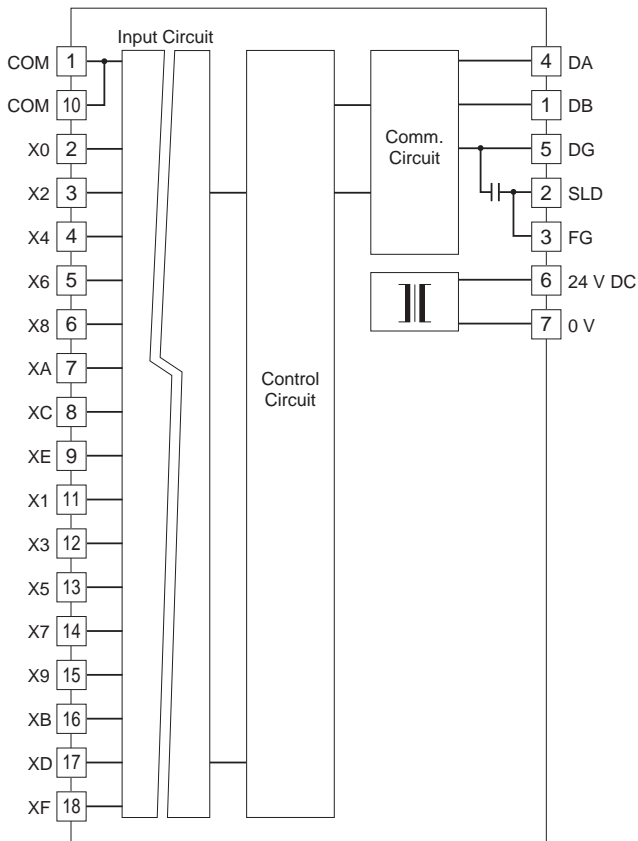

■ Input Circuit

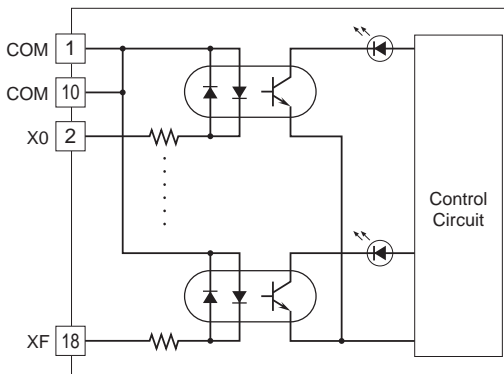

■ Input Connection Examples

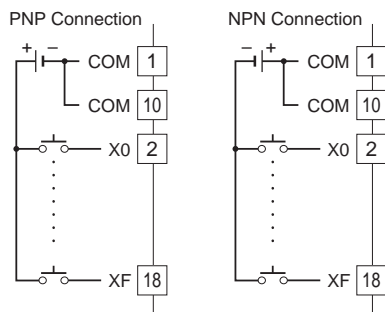

NPN TRANSISTOR OUTPUT MODULE, 16 points

CIRCUIT DIAGRAM

MODEL: R7C-DC16A

SPECIFICATIONS

- Common:** Negative common (NPN) per 16 points
- Number of I/O:** Output, 16 points
- Maximum outputs applicable at once:** No limit (at 24 V DC)
- I/O status indicator:** LED turns on with closed contact.
- Isolation:** Output to power input to CC-Link or FG
- CC-Link:** Conforms to Version 1.10
- Station type:** Remote I/O
- Data allocation:** 1
- Rated load voltage:** 24 V DC $\pm 10\%$
- Rated output current:** 0.25 A per point, 2.0 A per common
- Residual voltage:** ≤ 1.2 V
- Leakage current:** ≤ 0.1 mA
- ON delay:** ≤ 0.5 msec.
- OFF delay:** ≤ 1.5 msec.

OPERATING MODE SETTING

(*) Factory setting

Caution ! - SW1-6, 1-7, 1-8 are unused. Be sure to turn off unused ones.

• Output at the loss of communication (SW1-5)

SW1-5	OUTPUT AT THE LOSS OF COMMUNICATION
OFF	Reset the output (turned off)
ON	Hold the output (*) (maintains the last data received normally)

• Extension (SW1-1, 1-2, 1-3, 1-4)

SW1-1	SW1-2	SW1-3	SW1-4	EXTENSION
OFF	ON	OFF	OFF	No extension (*)
OFF	ON	OFF	ON	Discrete output, 8 or 16 points

TERMINAL ASSIGNMENTS

10	11	12	13	14	15	16	17	18
+24 V	Y1	Y3	Y5	Y7	Y9	YB	YD	YF
1	2	3	4	5	6	7	8	9
0 V	Y0	Y2	Y4	Y6	Y8	YA	YC	YE

NO.	ID	FUNCTION	NO.	ID	FUNCTION
1	0 V	0 V (common)	10	+24 V	24 V DC
2	Y0	Output 0	11	Y1	Output 1
3	Y2	Output 2	12	Y3	Output 3
4	Y4	Output 4	13	Y5	Output 5
5	Y6	Output 6	14	Y7	Output 7
6	Y8	Output 8	15	Y9	Output 9
7	YA	Output 10	16	YB	Output 11
8	YC	Output 12	17	YD	Output 13
9	YE	Output 14	18	YF	Output 15

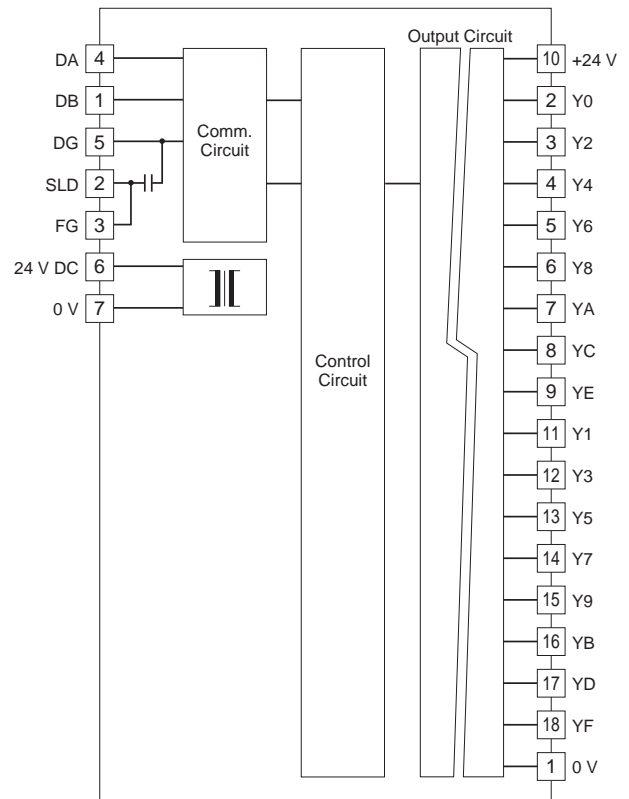

■ Output Circuit

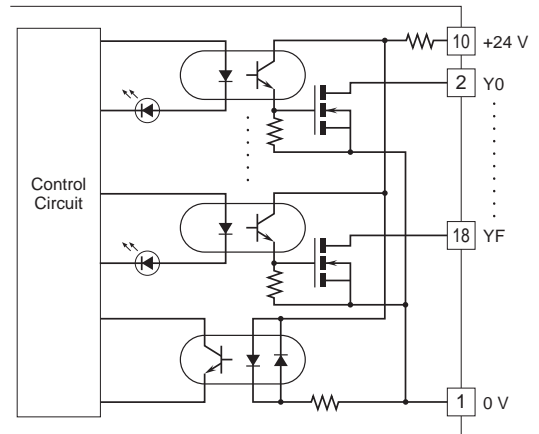

■ Output Connection Example

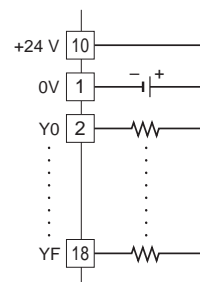

PNP TRANSISTOR OUTPUT MODULE, 16 points

CIRCUIT DIAGRAM

MODEL: R7C-DC16B

SPECIFICATIONS

- Common:** Positive common (PNP) per 16 points
- Number of I/O:** Output, 16 points
- Maximum outputs applicable at once:** No limit (at 24 V DC)
- I/O status indicator:** LED turns on with closed contact.
- Isolation:** Output to power input to CC-Link or FG
- CC-Link:** Conforms to Version 1.10
- Station type:** Remote I/O
- Data allocation:** 1
- Rated load voltage:** 24 V DC $\pm 10\%$
- Rated output current:** 0.25 A per point, 2.0 A per common
- Residual voltage:** ≤ 1.2 V
- Leakage current:** ≤ 0.1 mA
- ON delay:** ≤ 0.5 msec.
- OFF delay:** ≤ 1.5 msec.

OPERATING MODE SETTING

(*) Factory setting

Caution ! - SW1-6, 1-7, 1-8 are unused. Be sure to turn off unused ones.

• Output at the loss of communication (SW1-5)

SW1-5	OUTPUT AT THE LOSS OF COMMUNICATION
OFF	Reset the output (turned off)
ON	Hold the output (*) (maintains the last data received normally)

• Extension (SW1-1, 1-2, 1-3, 1-4)

SW1-1	SW1-2	SW1-3	SW1-4	EXTENSION
OFF	ON	OFF	OFF	No extension (*)
OFF	ON	OFF	ON	Discrete output, 8 or 16 points

TERMINAL ASSIGNMENTS

10	11	12	13	14	15	16	17	18
+24 V	Y1	Y3	Y5	Y7	Y9	YB	YD	YF
1	2	3	4	5	6	7	8	9
0 V	Y0	Y2	Y4	Y6	Y8	YA	YC	YE

NO.	ID	FUNCTION	NO.	ID	FUNCTION
1	0 V	0 V	10	+24 V	24 V DC (common)
2	Y0	Output 0	11	Y1	Output 1
3	Y2	Output 2	12	Y3	Output 3
4	Y4	Output 4	13	Y5	Output 5
5	Y6	Output 6	14	Y7	Output 7
6	Y8	Output 8	15	Y9	Output 9
7	YA	Output 10	16	YB	Output 11
8	YC	Output 12	17	YD	Output 13
9	YE	Output 14	18	YF	Output 15

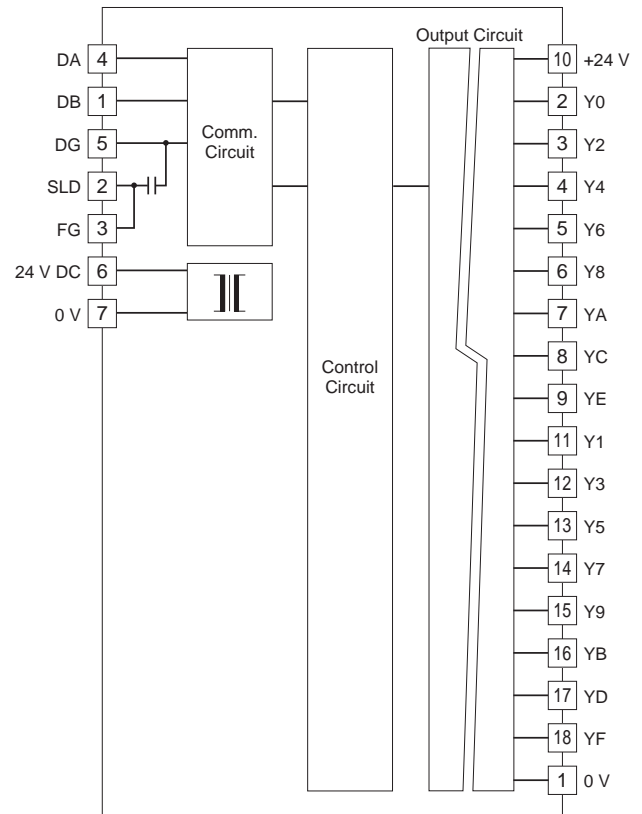

■ Output Circuit

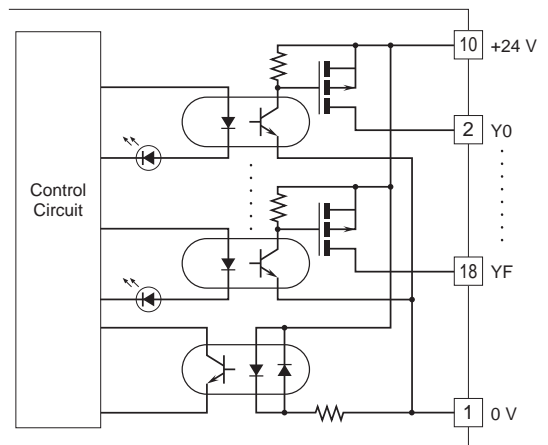

■ Output Connection Example

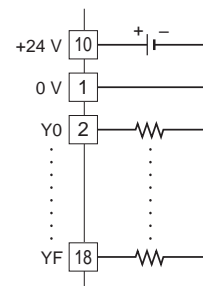

RELAY CONTACT OUTPUT MODULE, 8 points

MODEL: R7C-DC8C

SPECIFICATIONS

- Common:** 1 common per 4 points (4 terminals)
- Common current:** Max. 8 A (4 terminals)
- Number of I/O:** Relay contact output, 8 points
- Maximum outputs applicable at once:** No limit (at 24 V DC)
- I/O status indicator:** LED turns on with closed contact.
- Isolation:** Output to power input to CC-Link or FG
- CC-Link:** Conforms to Version 1.10
- Station type:** Remote I/O
- Data allocation:** 1
- Relay driving power:** 24 V DC $\pm 10\%$, ≥ 60 mA
- Rated load:** 250 V AC* @2 A ($\cos \phi = 1$)
30 V DC @2 A (resistive load)
- Electrical life 10^5 cycles (rate 30/min.)
- *When it is used as a product relevant to EC directive, it should be used under the Installation Category I, 125 V AC or less.
- Maximum switching voltage:** 250 V AC or 30 V DC
- Maximum switching power:** 500 VA or 60 W
- Minimum load:** 24 V DC @5 mA
- Mechanical life:** 2×10^7 cycles (rate 300/min.)
- When driving an inductive load, external contact protection and noise quenching are recommended.
- ON delay:** ≤ 10 msec.
- OFF delay:** ≤ 10 msec.

OPERATING MODE SETTING

- (*) Factory setting
- Caution ! - SW1-1 through 1-3, 1-5 through 1-8 are unused.
- Be sure to turn off the unused ones.

• Output at the loss of communication (SW1-4)

SW1-4	OUTPUT AT THE LOSS OF COMMUNICATION
OFF	Reset the output (turned off)
ON	Hold the output (*) (maintains the last data received normally)

TERMINAL ASSIGNMENTS

10	11	12	13	14	15	16	17	18
+24 V	Y0	Y1	Y2	Y3	Y4	Y5	Y6	Y7
1	2	3	4	5	6	7	8	9
0 V	COM0	COM0	COM0	COM0	COM1	COM1	COM1	COM1

NO.	ID	FUNCTION	NO.	ID	FUNCTION
1	0 V	0 V	10	+24 V	24 V DC
2	COM0	Common 0	11	Y0	Output 0
3	COM0	Common 0	12	Y1	Output 1
4	COM0	Common 0	13	Y2	Output 2
5	COM0	Common 0	14	Y3	Output 3
6	COM1	Common 1	15	Y4	Output 4
7	COM1	Common 1	16	Y5	Output 5
8	COM1	Common 1	17	Y6	Output 6
9	COM1	Common 1	18	Y7	Output 7

CIRCUIT DIAGRAM

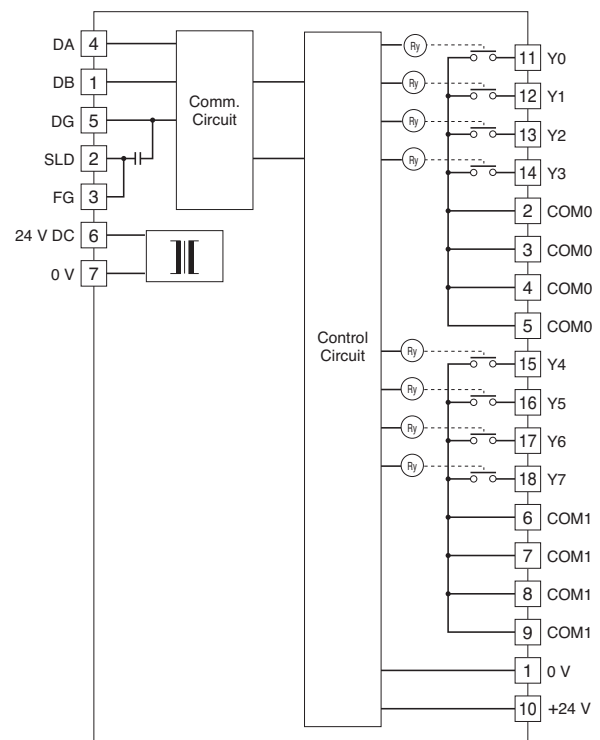

■ Output Connection Example

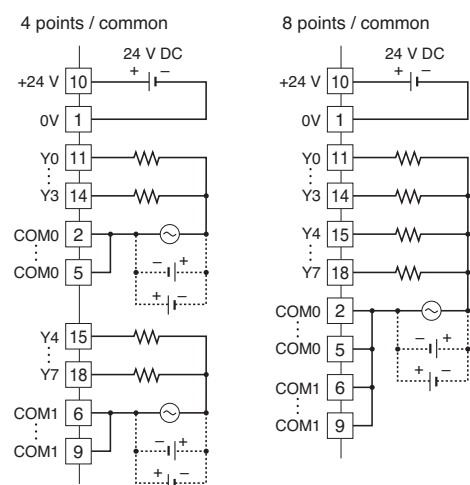

RELAY CONTACT OUTPUT MODULE, 8 points

MODEL: R7C-DC8E

SPECIFICATIONS

- Common:** 1 common per 4 points (4 terminals)
- Common current:** Max. 8 A (4 terminals)
- Number of I/O:** Relay contact output, 8 points
- Maximum outputs applicable at once:** No limit (at 24 V DC)
- I/O status indicator:** LED turns on with closed contact.
- Isolation:** Output to power input to CC-Link or FG
- CC-Link:** Conforms to Version 1.10
- Station type:** Remote I/O
- Data allocation:** 1
- Relay driving power:** 24 V DC $\pm 10\%$, ≥ 60 mA
- Rated load:** 250 V AC* @2 A ($\cos \phi = 1$)
30 V DC @2 A (resistive load)
- Electrical life 10^5 cycles (rate 30/min.)
- *When it is used as a product relevant to EC directive, it should be used under the Installation Category I, 125 V AC or less.
- Maximum switching voltage:** 250 V AC or 30 V DC
- Maximum switching power:** 500 VA or 60 W
- Minimum load:** 24 V DC @5 mA
- Mechanical life:** 2×10^7 cycles (rate 300/min.)
- When driving an inductive load, external contact protection and noise quenching are recommended.
- ON delay:** ≤ 10 msec.
- OFF delay:** ≤ 10 msec.

OPERATING MODE SETTING

(*) Factory setting
Caution ! - SW1-6, 1-7, 1-8 are unused. Be sure to turn off unused ones.

• Output at the loss of communication (SW1-5)

SW1-5	OUTPUT AT THE LOSS OF COMMUNICATION
OFF	Reset the output (turned off)
ON	Hold the output (*) (maintains the last data received normally)

• Extension (SW1-1, 1-2, 1-3, 1-4)

SW1-1	SW1-2	SW1-3	SW1-4	EXTENSION
OFF	ON	OFF	OFF	No extension (*)
OFF	ON	OFF	ON	Discrete output, 8 or 16 points

TERMINAL ASSIGNMENTS

10	11	12	13	14	15	16	17	18
+24 V	Y0	Y1	Y2	Y3	Y4	Y5	Y6	Y7
1	2	3	4	5	6	7	8	9
0 V	COM0	COM0	COM0	COM0	COM1	COM1	COM1	COM1

NO.	ID	FUNCTION	NO.	ID	FUNCTION
1	0 V	0 V	10	+24 V	24 V DC
2	COM0	Common 0	11	Y0	Output 0
3	COM0	Common 0	12	Y1	Output 1
4	COM0	Common 0	13	Y2	Output 2
5	COM0	Common 0	14	Y3	Output 3
6	COM1	Common 1	15	Y4	Output 4
7	COM1	Common 1	16	Y5	Output 5
8	COM1	Common 1	17	Y6	Output 6
9	COM1	Common 1	18	Y7	Output 7

CIRCUIT DIAGRAM

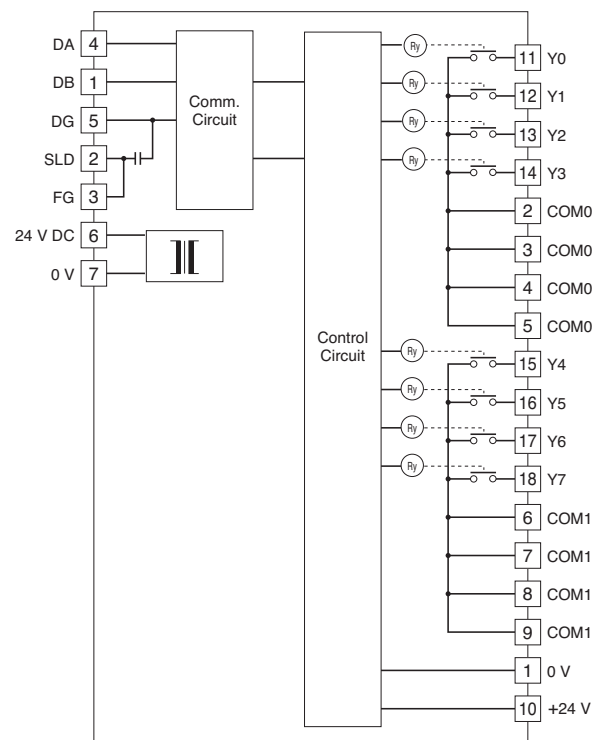

Output Connection Example

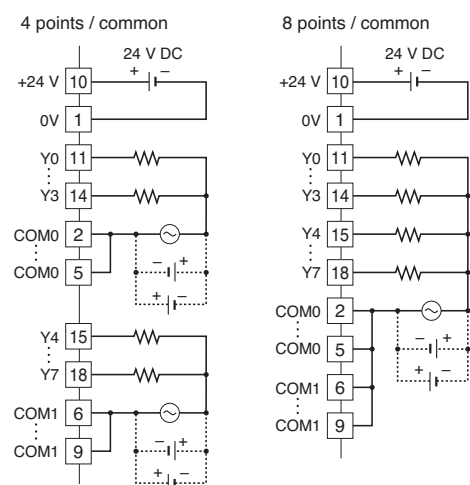

REMOTE CONTROL RELAY CONTROL MODULE

MODEL: R7C-RR4

SPECIFICATIONS

Common: 1 common per 4 points (4 terminals)
Number of I/O: Output, 4 points
Maximum outputs applicable at once: No limit
I/O status indicator: Feedback input status turns on with the input supplied.
 Output status turns on with the output ON.
Isolation: Output to power input to CC-Link or FG
CC-Link: Conforms to Version 1.10
Station type: Remote I/O
Data allocation: 1
Rated load voltage: 24 V AC $\pm 10\%$ (supplied by the remote control transformer)
Load voltage frequency: 50 / 60 Hz

OPERATING MODE SETTING

Each output is set with 2 bits. Output setting is explained on the table below.

NO.	BIT	SETTING	FUNCTION
Output 0	8, 9	0, 0	No operation
		1, 0	Output 0 ON
		0, 1	Output 0 OFF
		1, 1	Invalid
Output 1	10, 11	0, 0	No operation
		1, 0	Output 1 ON
		0, 1	Output 1 OFF
		1, 1	Invalid
Output 2	12, 13	0, 0	No operation
		1, 0	Output 2 ON
		0, 1	Output 2 OFF
		1, 1	Invalid
Output 3	14, 15	0, 0	No operation
		1, 0	Output 3 ON
		0, 1	Output 3 OFF
		1, 1	Invalid

Do not set both bits 1. If the 2 bits are simultaneously 1, the module will not operate normally.

For repeating the output of ON pulse, after setting (0, 0), set (1, 0) once again.

TERMINAL ASSIGNMENTS

6	7	8	9	10
NC	Y0	Y1	Y2	Y3
1	2	3	4	5
NC	C0	C1	C2	C3

NO.	ID	FUNCTION	NO.	ID	FUNCTION
1	NC	No connection	6	NC	No connection
2	C0	Common 0	7	Y0	Output 0
3	C1	Common 1	8	Y1	Output 1
4	C2	Common 2	9	Y2	Output 2
5	C3	Common 3	10	Y3	Output 3

CIRCUIT DIAGRAM

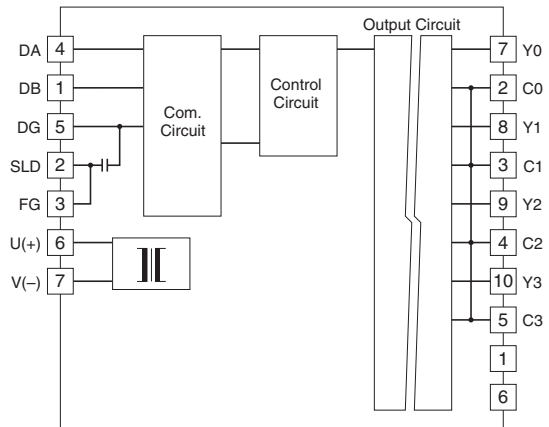

Output Connection Example

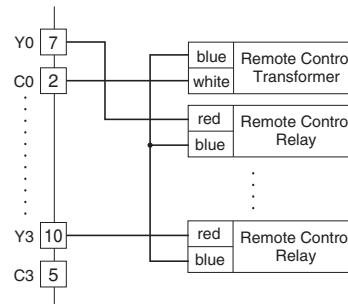

DC VOLTAGE/CURRENT INPUT MODULE, 4 points

MODEL: R7C-SV4

SPECIFICATIONS

Isolation: Input 0 to input 1 to input 2 to input 3 to power input to CC-Link or FG

CC-Link: Conforms to Version 1.10

Station type: Remote device

Data allocation: 1

Converted data range: 0 - 10000 of the input range

• **Input range**

Wide span voltage: -10 - +10 V DC, -5 - +5 V DC, 0 - 10 V DC, 0 - 5 V DC, 1 - 5 V DC

Narrow span voltage: -1 - +1 V DC, 0 - 1 V DC, -0.5 - +0.5 V DC

Current range: -20 - +20 mA DC, 0 - 20 mA DC, 4 - 20 mA DC

• **Input resistance**

Wide span voltage: $\geq 1 \text{ M}\Omega$

Narrow span voltage: $\geq 100 \text{ k}\Omega$

Current range: 70Ω

Conversion rate / conversion accuracy:

10 msec./ $\pm 0.8 \%$, 20 msec./ $\pm 0.4 \%$, 40 msec./ $\pm 0.2 \%$, 80 msec./ $\pm 0.1 \%$

Response time: Conversion rate $\times 2 + 50$ msec. (0 - 90 %)

Temperature coefficient: $\pm 0.015 \%/^{\circ}\text{C}$ ($\pm 0.008 \%/^{\circ}\text{F}$)

OPERATING MODE SETTING

(*) Factory setting

• **Input range (SW1-5, 1-6, 1-7, 1-8)**

SW1-5	SW1-6	SW1-7	SW1-8	INPUT RANGE
OFF	OFF	OFF	OFF	-10 - +10 V DC (*)
ON	OFF	OFF	OFF	-5 - +5 V DC
OFF	ON	OFF	OFF	-1 - +1 V DC
ON	ON	OFF	OFF	0 - 10 V DC
OFF	OFF	ON	OFF	0 - 5 V DC
ON	OFF	ON	OFF	1 - 5 V DC
OFF	ON	ON	OFF	0 - 1V DC
ON	ON	ON	OFF	-0.5 - +0.5 V DC
ON	OFF	OFF	ON	-20 - +20 mA DC
OFF	ON	OFF	ON	4 - 20 mA DC
ON	ON	OFF	ON	0 - 20 mA DC
ON	ON	ON	ON	PC Configurator setting

• **Conversion rate / Accuracy (SW1-3, 1-4)**

SW1-3	SW1-4	CONVERSION RATE / ACCURACY
OFF	OFF	80 msec. / $\pm 0.1\%$ (*)
ON	OFF	40 msec. / $\pm 0.2\%$
OFF	ON	20 msec. / $\pm 0.4\%$
ON	ON	10 msec. / $\pm 0.8\%$

• **Extension (SW1-1, 1-2)**

SW1-1	SW1-2	EXTENSION
OFF	OFF	No extension (*)
ON	OFF	Discrete input, 8 or 16 points
OFF	ON	Discrete output, 8 or 16 points

TERMINAL ASSIGNMENTS

10	11	12	13	14	15	16	17	18
VL0	I0	VL1	I1	NC	VL2	I2	VL3	I3
1	2	3	4	5	6	7	8	9
VH0	COM0	VH1	COM1	NC	VH2	COM2	VH3	COM3

NO.	ID	FUNCTION	NO.	ID	FUNCTION
1	VH0	Wide span volt. 0	10	VL0	Narrow span volt. 0
2	COM0	Common 0	11	I0	Current range 0
3	VH1	Wide span volt. 1	12	VL1	Narrow span volt. 1
4	COM1	Common 1	13	I1	Current range 1
5	NC	No connection	14	NC	No connection
6	VH2	Wide span volt. 2	15	VL2	Narrow span volt. 2
7	COM2	Common 2	16	I2	Current range 2
8	VH3	Wide span volt. 3	17	VL3	Narrow span volt. 3
9	COM3	Common 3	18	I3	Current range 3

CIRCUIT DIAGRAM

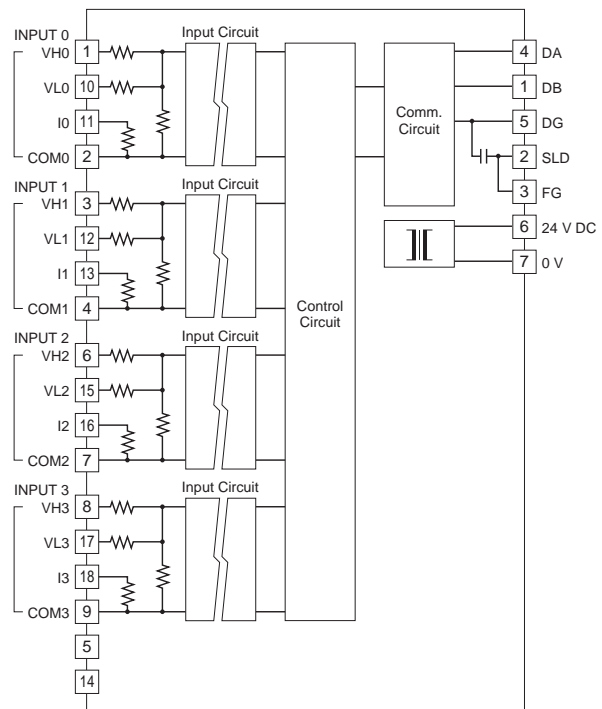

■ **Input Connection Examples**

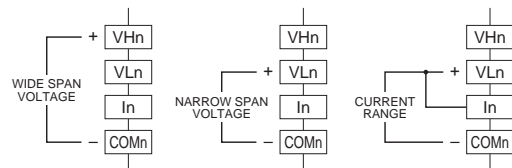

Be sure to close across VLn and In terminals for a current input.



THERMOCOUPLE INPUT MODULE, 4 points

MODEL: R7C-TS4

SPECIFICATIONS

Isolation: Input 0 to input 1 to input 2 to input 3 to power input to CC-Link or FG

CC-Link: Conforms to Version 1.10

Station type: Remote device

Data allocation: 1

Converted data range: Engineering unit value (°C, K) × 10 (integer); No multiplication for °F

Thermocouple: K, E, J, T, B, R, S, C, N, U, L, P, PR

Input resistance: ≥ 30 kΩ

Burnout sensing: ≤ 0.1 μA

Conversion accuracy: ±1°C (±1.8°F);

±2.0°C (±3.6°F) for B, R, S, C, PR

Conversion rate: 250 msec. or 500 msec.

Response time: Conversion rate × 2 + 50 msec. (0 - 90 %)

Temperature coefficient: ±0.015 %/°C (±0.008 %/°F)

CJC error: ±1.0°C at 25°C ±10°C

(±1.8°F at 77°F ±18°F)

±1.5°C (±2.7°F) for R, S, PR

T/C	BURNOUT INDICATION (°C)		CONFORMANCE RANGE (°C)
	Downscale	Upscale	
K (CA)	-272	+1472	-150 to +1370
E (CRC)	-272	+1120	-170 to +1000
J (IC)	-260	+1300	-180 to +1200
T (CC)	-272	+ 500	-170 to + 400
B (RH)	24	1920	400 to 1760
R	-100	+1860	200 to 1760
S	-100	+1860	0 to 1760
C (WRe 5-26)	-52	+2416	0 to 2315
N	-272	+1400	-130 to +1300
U	-252	+ 700	-200 to +600
L	-252	+1000	-200 to +900
P (Platinel II)	-52	+1496	0 to 1395
(PR)	-52	+1860	0 to 1760

T/C	BURNOUT INDICATION (°F)		CONFORMANCE RANGE (°F)
	Downscale	Upscale	
K (CA)	-458	+2682	-238 to +2498
E (CRC)	-458	+2048	-274 to +1832
J (IC)	-436	+2372	-292 to +2192
T (CC)	-458	+932	-274 to +752
B (RH)	75	3488	752 to 3200
R	-148	+3380	392 to 3200
S	-148	+3380	32 to 3200
C (WRe 5-26)	-62	+4381	32 to 4199
N	-458	+2552	-202 to +2372
U	-422	+1292	-328 to +1112
L	-422	+1832	-328 to +1652
P (Platinel II)	-62	+2725	32 to 2543
(PR)	-62	+3380	32 to 3200

OPERATING MODE SETTING

(*) Factory setting

• Thermocouple type (SW1-5, 1-6, 1-7, 1-8)

SW1-5	SW1-6	SW1-7	SW1-8	THERMOCOUPLE TYPE
OFF	OFF	OFF	OFF	K (CA) (*)
ON	OFF	OFF	OFF	E (CRC)
OFF	ON	OFF	OFF	J (IC)
ON	ON	OFF	OFF	T (CC)
OFF	OFF	ON	OFF	B (RH)
ON	OFF	ON	OFF	R
OFF	ON	ON	OFF	S
ON	ON	ON	OFF	C (WRe 5-26)
OFF	OFF	OFF	ON	N
ON	OFF	OFF	ON	U
OFF	ON	OFF	ON	L
ON	ON	OFF	ON	P (Platinel II)
OFF	OFF	ON	ON	(PR)
ON	ON	ON	ON	PC Configurator setting

• Conversion rate (SW1-3)

SW1-3	CONVERSION RATE
OFF	250 msec. (*)
ON	500 msec.

• Burnout (SW1-4)

SW1-4	BURNOUT
OFF	Upscale (*)
ON	Downscale

• Extension (SW1-1, 1-2)

SW1-1	SW1-2	EXTENSION
OFF	OFF	No extension (*)
ON	OFF	Discrete input, 8 or 16 points
OFF	ON	Discrete output, 8 or 16 points

TERMINAL ASSIGNMENTS

10	11	12	13	14	15	16	17	18
+IN0	-IN0	+IN1	-IN1	NC	+IN2	-IN2	+IN3	-IN3
1	2	3	4	5	6	7	8	9
+CJ0	-CJ0	+CJ1	-CJ1	NC	+CJ2	-CJ2	+CJ3	-CJ3

NO.	ID	FUNCTION	NO.	ID	FUNCTION
1	+CJ0	CJC 0	10	+IN0	T/C + 0
2	-CJ0	CJC 0	11	-IN0	T/C - 0
3	+CJ1	CJC 1	12	+IN1	T/C + 1
4	-CJ1	CJC 1	13	-IN1	T/C - 1
5	NC	No connection	14	NC	No connection
6	+CJ2	CJC 2	15	+IN2	T/C + 2
7	-CJ2	CJC 2	16	-IN2	T/C - 2
8	+CJ3	CJC 3	17	+IN3	T/C + 3
9	-CJ3	CJC 3	18	-IN3	T/C - 3



CIRCUIT DIAGRAM

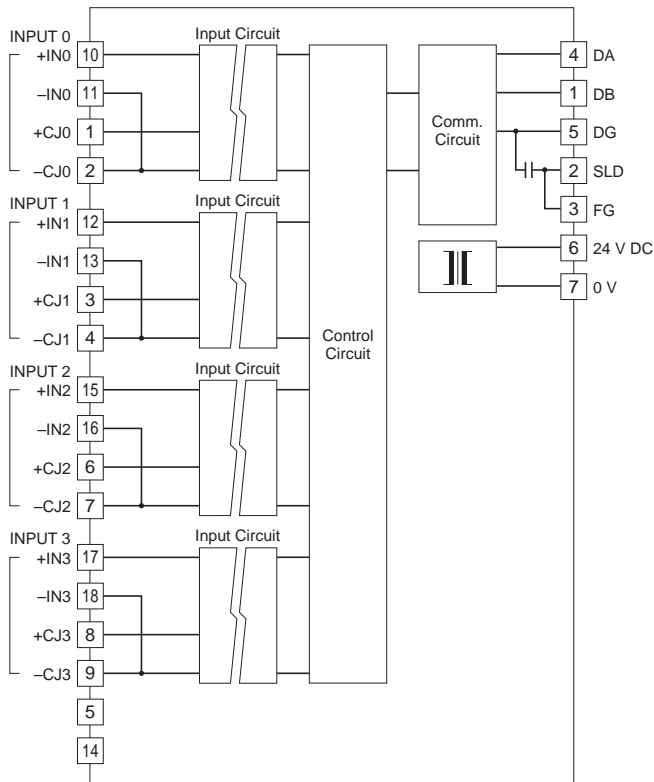

■ Input Connection Example

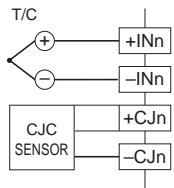

RTD INPUT MODULE, 4 points

MODEL: R7C-RS4

SPECIFICATIONS

Isolation: Input 0 to input 1 to input 2 to input 3 to power input to CC-Link or FG

CC-Link: Conforms to Version 1.10

Station type: Remote device

Data allocation: 1

Converted data range: Engineering unit value (°C, K) × 10 (integer); No multiplication for °F

RTD: Pt 100 (JIS '97, IEC), Pt 100 (JIS '89), JPt 100 (JIS '89), Pt 50 Ω (JIS '81), Ni 100, Cu 10, Cu 50

Sensing current: ≤ 1 mA

Input resistance: ≥ 1 MΩ

Maximum leadwire resistance: 100 Ω per wire

Conversion accuracy: ±1°C (±1.8°F);

±3°C (±5.4°F) for Cu 10

Conversion rate: 250 msec. or 500 msec.

Response time: Conversion rate × 2 + 50 msec. (0 - 90 %)

Temperature coefficient: ±0.015 %/°C (±0.008 %/°F)

RTD	BURNOUT INDICATION (°C)		CONFORMANCE RANGE (°C)
	Downscale	Upscale	
Pt 100 (JIS '97/IEC)	-240	+900	-200 to +850
Pt 100 (JIS '89)	-240	+900	-200 to +660
JPt 100 (JIS '89)	-236	+560	-200 to +510
Pt 50 Ω (JIS '81)	-236	+700	-200 to +649
Ni 100	-100	+252	-80 to +250
Cu 10 (25°C)	-212	+312	-50 to +250
Cu 50	-100	+200	-50 to +150

RTD	BURNOUT INDICATION (°F)		CONFORMANCE RANGE (°F)
	Downscale	Upscale	
Pt 100 (JIS '97/IEC)	-400	+1652	-328 to +1562
Pt 100 (JIS '89)	-400	+1652	-328 to +1220
JPt 100 (JIS '89)	-393	+1040	-328 to +950
Pt 50 Ω (JIS '81)	-393	+1292	-328 to +1200
Ni 100	-148	+486	-112 to +482
Cu 10 (25°C)	-350	+594	-58 to +482
Cu 50	-148	+392	-58 to +302

OPERATING MODE SETTING

(*) Factory setting

• RTD type (SW1-5, 1-6, 1-7, 1-8)

SW1-5	SW1-6	SW1-7	SW1-8	RTD TYPE
OFF	OFF	OFF	OFF	Pt 100 (JIS '97/IEC) (*)
ON	OFF	OFF	OFF	Pt 100 (JIS '89)
OFF	ON	OFF	OFF	JPt 100 (JIS '89)
ON	ON	OFF	OFF	Pt 50 Ω (JIS '81)
OFF	OFF	ON	OFF	Ni 100
ON	OFF	ON	OFF	Cu 10 (25°C)
OFF	OFF	OFF	ON	Cu 50
ON	ON	ON	ON	PC Configurator setting

• Conversion rate (SW1-3)

SW1-3	CONVERSION RATE
OFF	250 msec. (*)
ON	500 msec.

• Burnout (SW1-4)

SW1-4	BURNOUT
OFF	Upscale (*)
ON	Downscale

• Extension (SW1-1, 1-2)

SW1-1	SW1-2	EXTENSION
OFF	OFF	No extension (*)
ON	OFF	Discrete input, 8 or 16 points
OFF	ON	Discrete output, 8 or 16 points

TERMINAL ASSIGNMENTS

10	11	12	13	14	15	16	17	18
INA0	INb0	INA1	INb1	NC	INA2	INb2	INA3	INb3
1	2	3	4	5	6	7	8	9
NC	INB0	NC	INB1	NC	NC	INB2	NC	INB3

NO.	ID	FUNCTION	NO.	ID	FUNCTION
1	NC	No connection	10	INA0	RTD 0-A
2	INB0	RTD 0-B	11	INb0	RTD 0-b
3	NC	No connection	12	INA1	RTD 1-A
4	INB1	RTD 1-B	13	INb1	RTD 1-b
5	NC	No connection	14	NC	No connection
6	NC	No connection	15	INA2	RTD 2-A
7	INB2	RTD 2-B	16	INb2	RTD 2-b
8	NC	No connection	17	INA3	RTD 3-A
9	INB3	RTD 3-B	18	INb3	RTD 3-b



CIRCUIT DIAGRAM

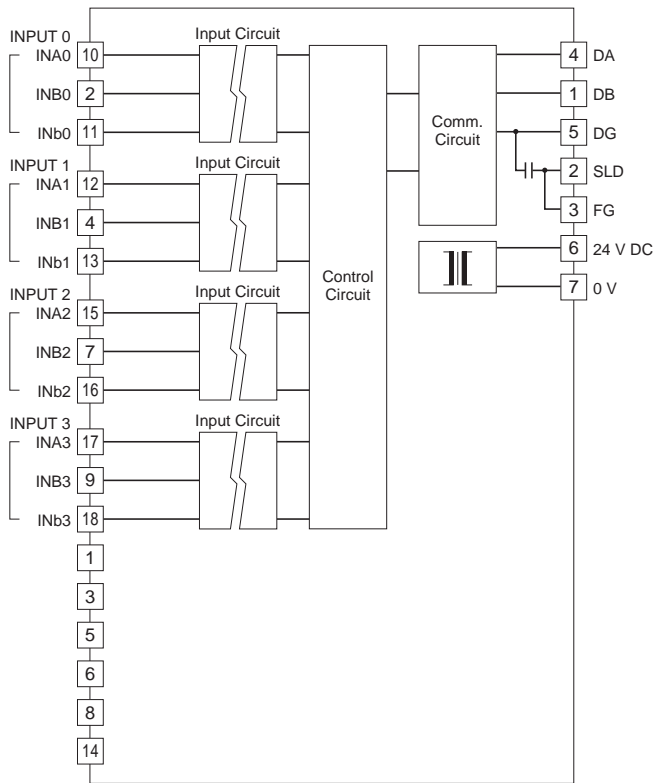

■ Input Connection Example

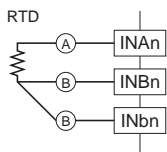

THERMISTOR INPUT MODULE, 4 points

MODEL: R7C-RT4A

SPECIFICATIONS

Isolation: Input 0 to input 1 to input 2 to input 3 to power input to CC-Link or FG

CC-Link: Conforms to Version 1.10

Station type: Remote device

Data allocation: 1

Converted data range: Engineering unit value (°C, K) × 10 (integer); No multiplication for °F

Thermistor: 502AT-11/502AT-2 (SEMITEC Corporation)

Excitation: Approx. 4.5 V DC (sensing resistance 15.8 kΩ)

Input resistance: ≥ 1 MΩ

Burnout response time: ≤ 2 sec.

Conversion accuracy: ±0.5°C (±0.9°F)

Conversion rate: 250 msec. or 500 msec.

Response time: Conversion rate × 2 + 50 msec. (0 - 90 %)

Temperature coefficient: ±0.15 %/°C (±0.08 %/°F)

THERMISTOR		BURNOUT INDICATION		CONFORMANCE RANGE
		Downscale	Upscale	
502AT-11	(°C)	-50	110	-40 to +90
502AT-2	(°F)	-58	230	-40 to +194

OPERATING MODE SETTING

(*) Factory setting

Caution ! - SW1-5, 1-6, 1-7, 1-8 are unused. Be sure to turn off unused ones.

• Conversion rate (SW1-3)

SW1-3	CONVERSION RATE
OFF	250 msec. (*)
ON	500 msec.

• Burnout (SW1-4)

SW1-4	BURNOUT
OFF	Upscale (*)
ON	Downscale

• Extension (SW1-1, 1-2)

SW1-1	SW1-2	EXTENSION
OFF	OFF	No extension (*)
ON	OFF	Discrete input, 8 or 16 points
OFF	ON	Discrete output, 8 or 16 points

TERMINAL ASSIGNMENTS

10	11	12	13	14	15	16	17	18
INA0	NC	INA1	NC	NC	INA2	NC	INA3	NC
1	2	3	4	5	6	7	8	9
NC	INB0	NC	INB1	NC	NC	INB2	NC	INB3

NO.	ID	FUNCTION	NO.	ID	FUNCTION
1	NC	No connection	10	INA0	Thermistor 0-A
2	INB0	Thermistor 0-B	11	NC	No connection
3	NC	No connection	12	INA1	Thermistor 1-A
4	INB1	Thermistor 1-B	13	NC	No connection
5	NC	No connection	14	NC	No connection
6	NC	No connection	15	INA2	Thermistor 2-A
7	INB2	Thermistor 2-B	16	NC	No connection
8	NC	No connection	17	INA3	Thermistor 3-A
9	INB3	Thermistor 3-B	18	NC	No connection

CIRCUIT DIAGRAM

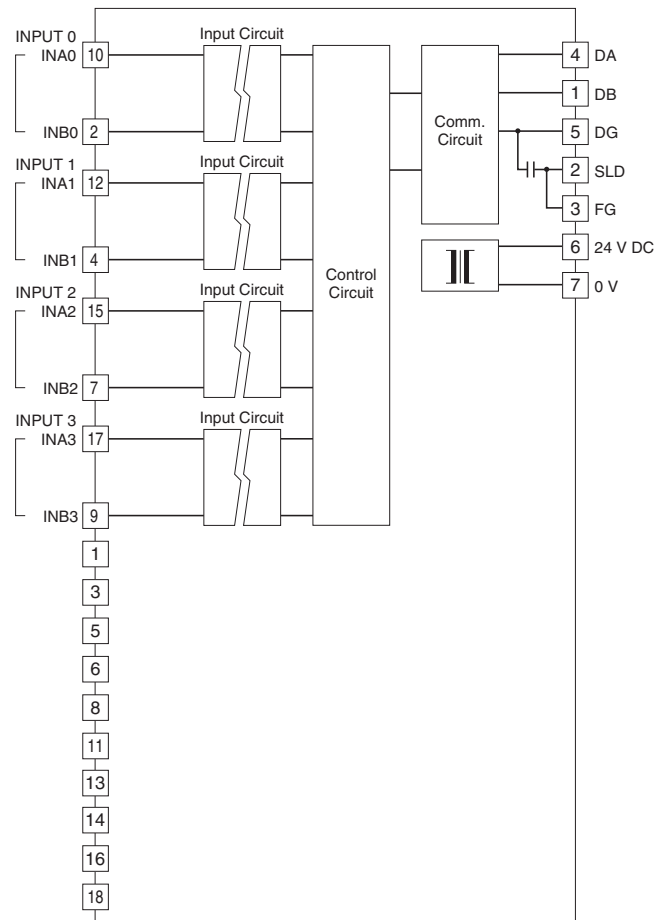

■ Input Connection Example

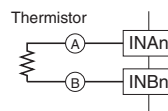

POTENTIOMETER INPUT MODULE, 4 points

MODEL: R7C-MS4

SPECIFICATIONS

Isolation: Input 0 to input 1 to input 2 to input 3 to power input to CC-Link or FG

CC-Link: Conforms to Version 1.10

Station type: Remote device

Data allocation: 1

Converted data range: 0 - 10000 of the input range

Potentiometer: Total resistance 100 Ω - 20 kΩ

Minimum span: 50 % of total resistance

Excitation: Approx. 0.2 V DC

Conversion rate / conversion accuracy:

10 msec./±0.8 %, 20 msec./±0.4 %, 40 msec./±0.2 %, 80 msec./±0.1 %

Response time: Conversion rate × 2 + 50 msec. (0 - 90 %)

Temperature coefficient: ±0.015 %/°C (±0.008 %/°F)

OPERATING MODE SETTING

(*) Factory setting

Caution ! - SW1-5, 1-6, 1-7, 1-8 are unused. Be sure to turn off unused ones.

• Conversion rate / Accuracy (SW1-3, 1-4)

SW1-3	SW1-4	CONVERSION RATE / ACCURACY
OFF	OFF	80 msec. / ±0.1% (*)
ON	OFF	40 msec. / ±0.2%
OFF	ON	20 msec. / ±0.4%
ON	ON	10 msec. / ±0.8%

• Extension (SW1-1, 1-2)

SW1-1	SW1-2	EXTENSION
OFF	OFF	No extension (*)
ON	OFF	Discrete input, 8 or 16 points
OFF	ON	Discrete output, 8 or 16 points

TERMINAL ASSIGNMENTS

10	11	12	13	14	15	16	17	18
H0	S0	H1	S1	NC	H2	S2	H3	S3
1	2	3	4	5	6	7	8	9
NC	L0	NC	L1	NC	NC	L2	NC	L3

NO.	ID	FUNCTION	NO.	ID	FUNCTION
1	NC	No connection	10	H0	Pot H0
2	L0	Pot L0	11	S0	Pot S0
3	NC	No connection	12	H1	Pot H1
4	L1	Pot L1	13	S1	Pot S1
5	NC	No connection	14	NC	No connection
6	NC	No connection	15	H2	Pot H2
7	L2	Pot L2	16	S2	Pot S2
8	NC	No connection	17	H3	Pot H3
9	L3	Pot L3	18	S3	Pot S3

CIRCUIT DIAGRAM

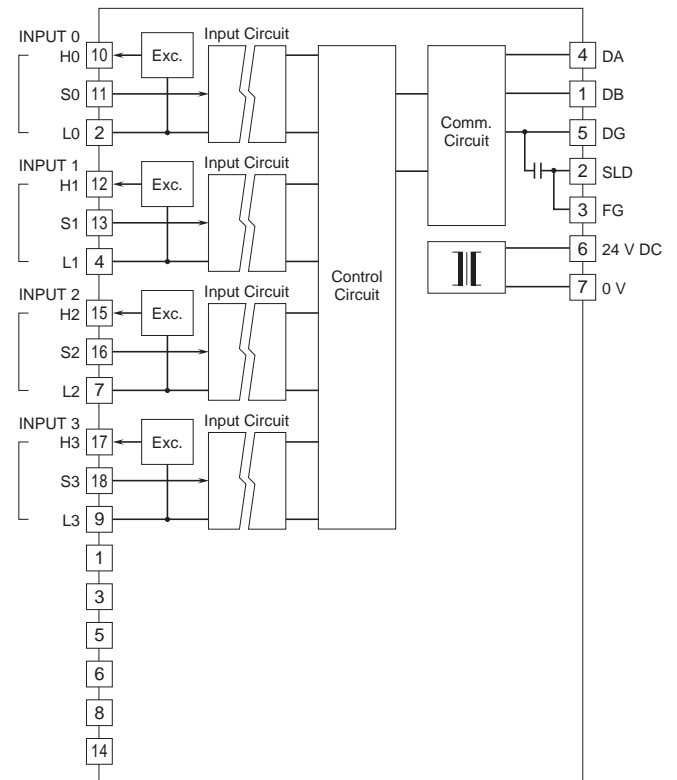

■ Input Connection Example

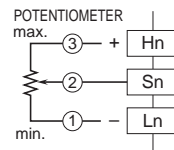

AC CURRENT INPUT MODULE, 4 points

(clamp-on current sensor CLSE use)

MODEL: R7C-CT4E

SPECIFICATIONS

Isolation: Input 0 to input 1 to input 2 to input 3 to power input to CC-Link or FG

CC-Link: Conforms to Version 1.10

Station type: Remote device

Data allocation: 1

Converted data range:

Engineering unit value (A) × 100 (Integer)

(Engineering unit value (A) × 1000 (Integer) for CLSE-R5)

Input range (Optional)

CLSE-R5: 0 - 5 A AC

CLSE-05: 0 - 50 A AC

CLSE-10: 0 - 100 A AC

CLSE-20: 0 - 200 A AC

CLSE-40: 0 - 400 A AC

CLSE-60: 0 - 600 A AC

Frequency: 50/60 Hz

Overload capacity: 120 % continuous

Operational range: 5 - 115 % of rating

Conversion rate / conversion accuracy:

10 msec./±2.0 %, 20 msec./±1.0 %, 40 msec./±0.5 %, 80 msec./±0.5 %

(The conversion accuracy does not include the accuracy of the sensor.)

Response time: ≤ 1.0 sec. (0 - 90 %)

Temperature coefficient: ±0.015 %/°C (±0.008 %/°F)

OPERATING MODE SETTING

(*) Factory setting

• **Input range (SW1-5, 1-6, 1-7, 1-8)**

SW1-5	SW1-6	SW1-7	SW1-8	INPUT RANGE
OFF	OFF	OFF	OFF	CLSE-60 (*)
ON	OFF	OFF	OFF	CLSE-40
OFF	ON	OFF	OFF	CLSE-20
ON	ON	OFF	OFF	CLSE-10
OFF	OFF	ON	OFF	CLSE-05
ON	OFF	ON	OFF	CLSE-R5
ON	ON	ON	ON	PC Configurator setting

• **Conversion rate / Accuracy (SW1-3, 1-4)**

SW1-3	SW1-4	CONVERSION RATE / ACCURACY
OFF	OFF	80 msec. / ±0.5% (*)
ON	OFF	40 msec. / ±0.5%
OFF	ON	20 msec. / ±1.0%
ON	ON	10 msec. / ±2.0%

• **Extension (SW1-1, 1-2)**

SW1-1	SW1-2	EXTENSION
OFF	OFF	No extension (*)
ON	OFF	Discrete input, 8 or 16 points
OFF	ON	Discrete output, 8 or 16 points

TERMINAL ASSIGNMENTS

10	11	12	13	14	15	16	17	18
K0	L0	K1	L1	NC	K2	L2	K3	L3
1	2	3	4	5	6	7	8	9
NC	NC	NC	NC	NC	NC	NC	NC	NC

NO.	ID	FUNCTION	NO.	ID	FUNCTION
1	NC	No connection	10	K0	AC current K0
2	NC	No connection	11	L0	AC current L0
3	NC	No connection	12	K1	AC current K1
4	NC	No connection	13	L1	AC current L1
5	NC	No connection	14	NC	No connection
6	NC	No connection	15	K2	AC current K2
7	NC	No connection	16	L2	AC current L2
8	NC	No connection	17	K3	AC current K3
9	NC	No connection	18	L3	AC current L3

CIRCUIT DIAGRAM

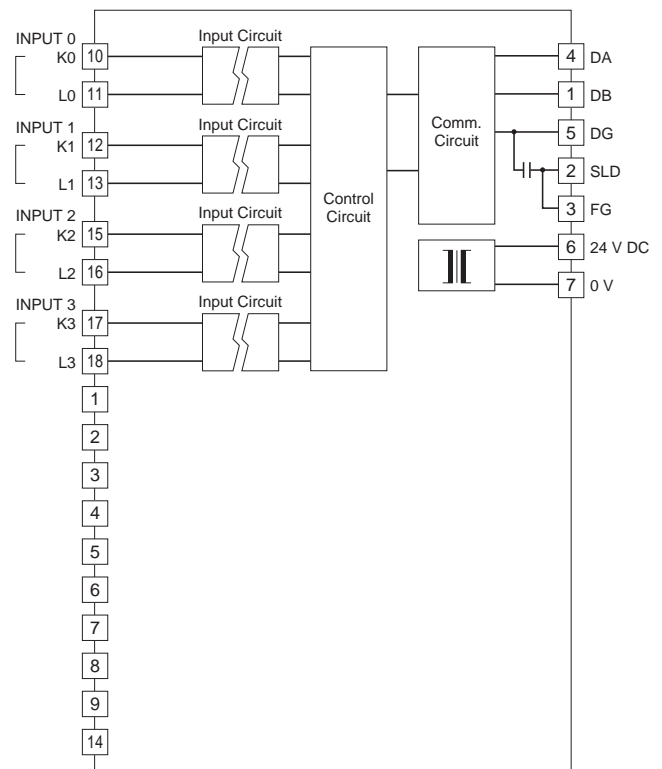

Input Connection Example

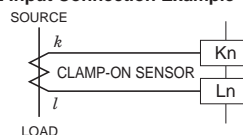

TOTALIZED PULSE INPUT MODULE, 8 points

MODEL: R7C-PA8

SPECIFICATIONS

Common: Positive or negative common (NPN/PNP) per 8 points

Number of I/O: Input, 8 points

I/O status indicator: LED turns on with closed contact.

Isolation: Input to power input to CC-Link or FG

CC-Link: Conforms to Version 1.10

Station type: Remote device

Data allocation: 1 or 4

■ **External excitation (PNP, NPN input)**

Sensing voltage: 24 V DC $\pm 10\%$; ripple 5 %p-p max

ON current / ON resistance: ≥ 3.7 mA (input terminal - COM)
/ ≤ 2 k Ω

OFF current / OFF resistance: ≤ 1 mA (input terminal - COM)
/ ≥ 20 k Ω

Voltage pulse input

ON voltage / ON current: ≥ 16 V DC (input terminal - COM) /
 ≤ 3.7 mA

OFF voltage / OFF current: ≤ 5 V DC (input terminal - COM) /
 ≤ 1 mA

Input current: ≤ 5.5 mA per point at 24 V DC

Input resistance: Approx. 4.4 k Ω

ON delay: ≤ 2.0 msec.

OFF delay: ≤ 2.0 msec.

Max. Frequency: 100 Hz

Minimum ON/OFF pulse requirements: 5 ms

Accumulated pulse count: 0 - 4 294 967 295

Overflow: 0 or 1

TERMINAL ASSIGNMENTS

10 V+	11 PI0	12 PI1	13 PI2	14 PI3	15 PI4	16 PI5	17 PI6	18 PI7
1 V-	2 C0	3 C1	4 C2	5 C3	6 C4	7 C5	8 C6	9 C7

NO.	ID	FUNCTION	NO.	ID	FUNCTION
1	V -	Power (-)	10	V +	Power (+)
2	C0	Common	11	PI0	Input 0
3	C1	Common	12	PI1	Input 1
4	C2	Common	13	PI2	Input 2
5	C3	Common	14	PI3	Input 3
6	C4	Common	15	PI4	Input 4
7	C5	Common	16	PI5	Input 5
8	C6	Common	17	PI6	Input 6
9	C7	Common	18	PI7	Input 7

OPERATING MODE SETTING

(*) Factory setting

Caution ! - SW1-4 through SW1-8 are unused. Be sure to turn off unused ones.

• Data allocation (SW1-3)

SW1-3	Data allocation
OFF	1 (*)
ON	4

• Extension (SW1-1, 1-2)

SW1-1	SW1-2	EXTENSION
OFF	OFF	No extension (*)
ON	OFF	Discrete input, 8 or 16 points
OFF	ON	Discrete output, 8 or 16 points



CIRCUIT DIAGRAM

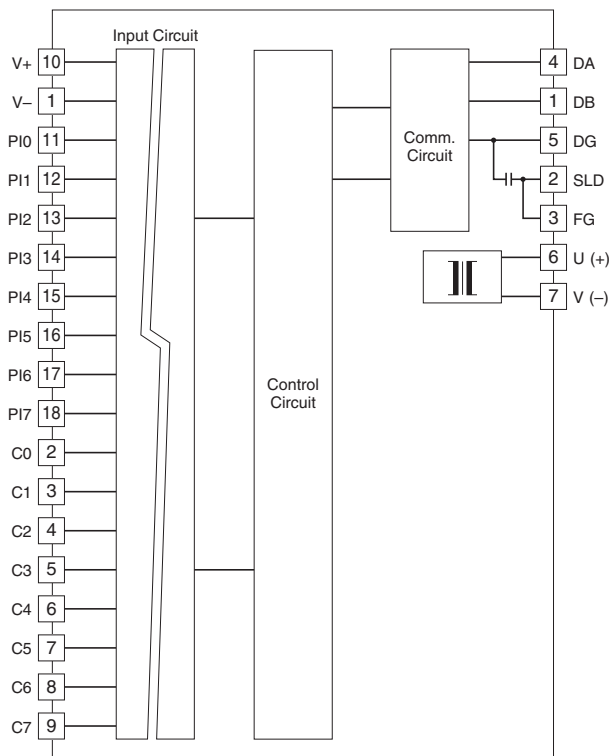

■ Input Circuit

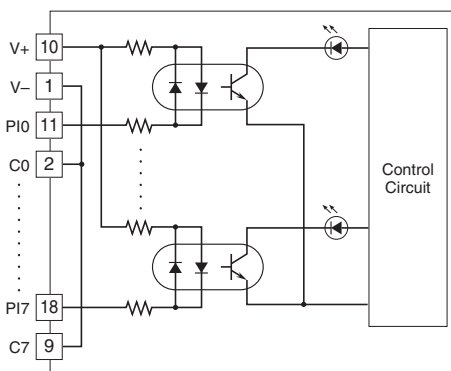

■ Input Connection Examples

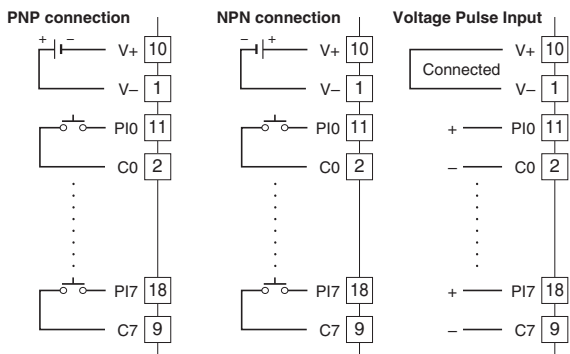

DC VOLTAGE OUTPUT MODULE, 2 points

MODEL: R7C-YV2

SPECIFICATIONS

Isolation: Output 0 to output 1 to power input to CC-Link or FG

CC-Link: Conforms to Version 1.10

Station type: Remote device

Data allocation: 1

Converted data range: 0 - 10000 of the output range

Output range

Wide span voltage: -10 - +10 V DC, -5 - +5 V DC,

0 - 10 V DC, 0 - 5 V DC, 1 - 5 V DC

Narrow span voltage: -1 - +1 V DC, 0 - 1 V DC,

-0.5 - +0.5 V DC

Operational range: -11.5 - +11.5 V DC or -15 - +115 %

Load resistance: $\geq 100 \text{ k}\Omega$

Conversion accuracy: $\pm 0.1 \%$

Response time: 250 msec. (0 - 90 %)

Temperature coefficient: $\pm 0.015 \%/^{\circ}\text{C}$ ($\pm 0.008 \%/^{\circ}\text{F}$)

OPERATING MODE SETTING

(*) Factory setting

Caution ! - SW1-3 is unused. Be sure to turn off unused ones.

• Output range (SW1-5, 1-6, 1-7, 1-8)

SW1-5	SW1-6	SW1-7	SW1-8	OUTPUT RANGE
OFF	OFF	OFF	OFF	-10 - +10 V DC (*)
ON	OFF	OFF	OFF	-5 - +5 V DC
OFF	ON	OFF	OFF	-1 - +1 V DC
ON	ON	OFF	OFF	0 - 10 V DC
OFF	OFF	ON	OFF	0 - 5 V DC
ON	OFF	ON	OFF	1 - 5 V DC
OFF	ON	ON	OFF	0 - 1 V DC
ON	ON	ON	OFF	-0.5 - +0.5 V DC
ON	ON	ON	ON	PC Configurator setting

• Output at the loss of communication (SW1-4)

SW1-4	OUTPUT AT THE LOSS OF COMMUNICATION
OFF	Reset the output (to -15% or approx. -11.5V DC)
ON	Hold the output (*) (maintains the last data received normally)

• Extension (SW1-1, 1-2)

SW1-1	SW1-2	EXTENSION
OFF	OFF	No extension (*)
ON	OFF	Discrete input, 8 or 16 points
OFF	ON	Discrete output, 8 or 16 points

TERMINAL ASSIGNMENTS

6	7	8	9	10
NC	VH0	VL0	VH1	VL1
1	2	3	4	5
NC	COM0	COM0	COM1	COM1

NO.	ID	FUNCTION	NO.	ID	FUNCTION
1	NC	No connection	6	NC	No connection
2	COM0	Common 0	7	VH0	Wide span volt. 0
3	COM0	Common 0	8	VL0	Narrow span volt. 0
4	COM1	Common 1	9	VH1	Wide span volt. 1
5	COM1	Common 1	10	VL1	Narrow span volt. 1

CIRCUIT DIAGRAM

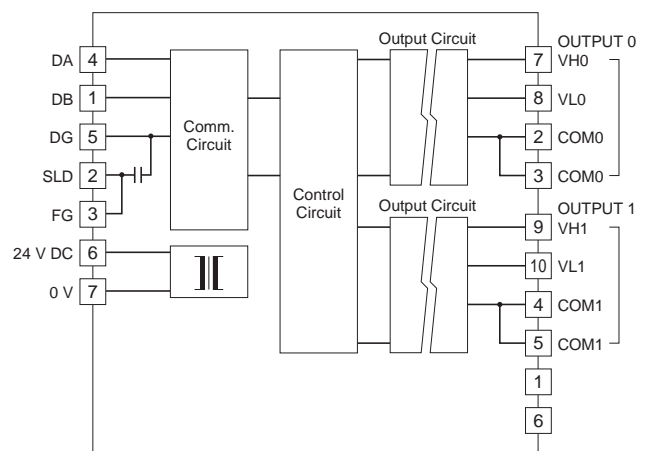

■ Output Connection Examples

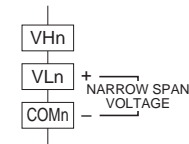
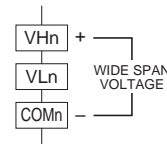

DC CURRENT OUTPUT MODULE, 2 points

CIRCUIT DIAGRAM

MODEL: R7C-YS2

SPECIFICATIONS

Isolation: Output 0 to output 1 to power input to CC-Link or FG

CC-Link: Conforms to Version 1.10

Station type: Remote device

Data allocation: 1

Converted data range: 0 - 10000 of the output range

Output range: 4 - 20 mA DC

Load resistance: $\leq 600\Omega$

Conversion accuracy: $\pm 0.1\%$

Response time: 250 msec. (0 - 90 %)

Temperature coefficient: $\pm 0.015\%/^{\circ}\text{C}$ ($\pm 0.008\%/^{\circ}\text{F}$)

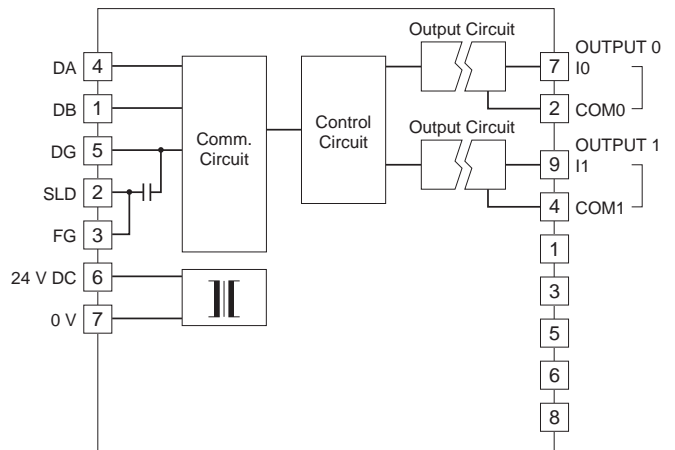

OPERATING MODE SETTING

(*) Factory setting

Caution ! - SW1-3, 1-5 through 1-8 are unused. Be sure to turn off unused ones.

• Output at the loss of communication (SW1-4)

SW1-4	OUTPUT AT THE LOSS OF COMMUNICATION
OFF	Reset the output (to -15%)
ON	Hold the output (*) (maintains the last data received normally)

• Extension (SW1-1, 1-2)

SW1-1	SW1-2	EXTENSION
OFF	OFF	No extension (*)
ON	OFF	Discrete input, 8 or 16 points
OFF	ON	Discrete output, 8 or 16 points

TERMINAL ASSIGNMENTS

6	7	8	9	10
NC	I0	NC	I1	NC
1	2	3	4	5
NC	COM0	NC	COM1	NC

NO.	ID	FUNCTION	NO.	ID	FUNCTION
1	NC	No connection	6	NC	No connection
2	COM0	Common 0	7	I0	Current 0
3	NC	No connection	8	NC	No connection
4	COM1	Common 1	9	I1	Current 1
5	NC	No connection	10	NC	No connection



DISCRETE INPUT EXTENSION MODULE, 8 points

CIRCUIT DIAGRAM

MODEL: R7C-EA8

SPECIFICATIONS

Common: Positive or negative common (NPN/PNP) per 8 points

Number of I/O: Input, 8 points

Maximum inputs applicable at once: No limit (at 24 V DC)

I/O status indicator: LED turns on with closed contact.

Isolation: Input to internal circuits

Rated input voltage: 24 V DC $\pm 10\%$; ripple 5 %p-p max.

ON voltage / current: ≥ 15 V DC (input - COM) / ≥ 3.5 mA

OFF voltage / current: ≤ 5 V DC (input - COM) / ≤ 1 mA

Input current: ≤ 5.5 mA per point at 24 V DC

Input resistance: Approx. 4.4 k Ω

ON delay: ≤ 2.0 msec.

OFF delay: ≤ 2.0 msec.

TERMINAL ASSIGNMENTS

6	7	8	9	10
NC	X1	X3	X5	X7
1	2	3	4	5
COM	X0	X2	X4	X6

NO.	ID	FUNCTION	NO.	ID	FUNCTION
1	COM	Common	6	NC	No Connection
2	X0	Input 0	7	X1	Input 1
3	X2	Input 2	8	X3	Input 3
4	X4	Input 4	9	X5	Input 5
5	X6	Input 6	10	X7	Input 7

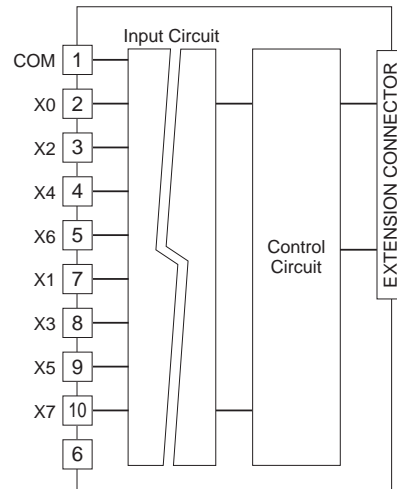

Input Circuit

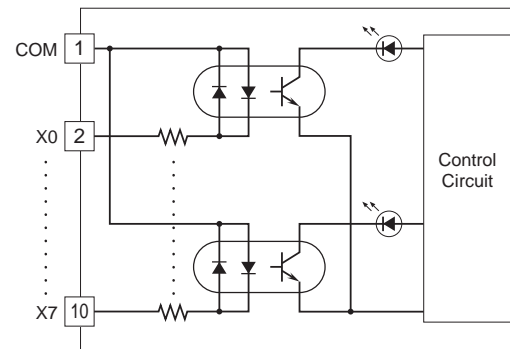

Input Connection Examples

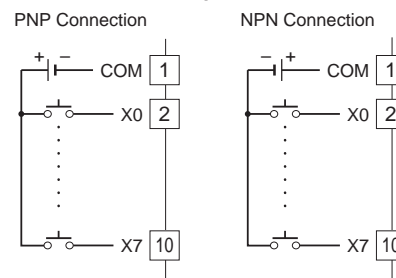

DISCRETE INPUT EXTENSION MODULE, 16 points

CIRCUIT DIAGRAM

MODEL: R7C-EA16

SPECIFICATIONS

Common: Positive or negative common (NPN/PNP) per 16 points

Number of I/O: Input, 16 points

Maximum inputs applicable at once: No limit (at 24 V DC)

I/O status indicator: LED turns on with closed contact.

Isolation: Input to internal circuits

Rated input voltage: 24 V DC $\pm 10\%$; ripple 5 %p-p max.

ON voltage / current: ≥ 15 V DC (input - COM) / ≥ 3.5 mA

OFF voltage / current: ≤ 5 V DC (input - COM) / ≤ 1 mA

Input current: ≤ 5.5 mA per point at 24 V DC

Input resistance: Approx. 4.4 k Ω

ON delay: ≤ 2.0 msec.

OFF delay: ≤ 2.0 msec.

TERMINAL ASSIGNMENTS

10	11	12	13	14	15	16	17	18
NC	X1	X3	X5	X7	X9	XB	XD	XF
1	2	3	4	5	6	7	8	9
COM	X0	X2	X4	X6	X8	XA	XC	XE

NO.	ID	FUNCTION	NO.	ID	FUNCTION
1	COM	Common	10	NC	No Connection
2	X0	Input 0	11	X1	Input 1
3	X2	Input 2	12	X3	Input 3
4	X4	Input 4	13	X5	Input 5
5	X6	Input 6	14	X7	Input 7
6	X8	Input 8	15	X9	Input 9
7	XA	Input 10	16	XB	Input 11
8	XC	Input 12	17	XD	Input 13
9	XE	Input 14	18	XF	Input 15

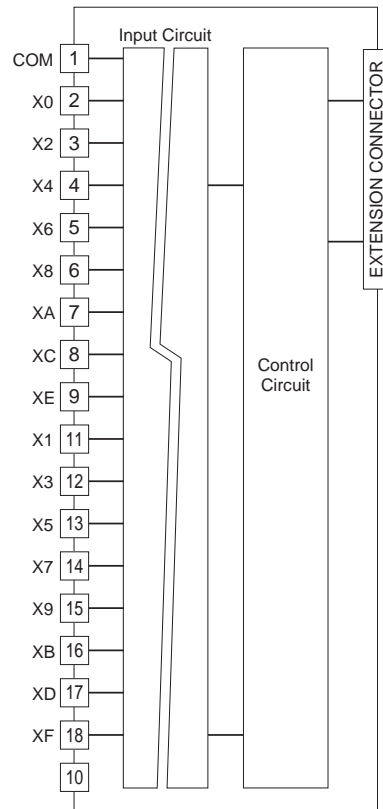

Input Circuit

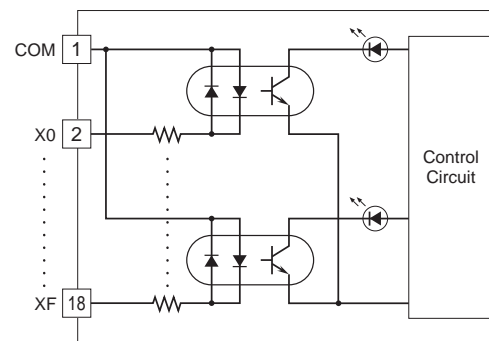

Input Connection Examples

PNP Connection

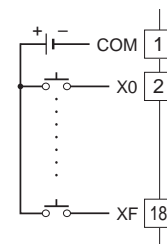

NPN Connection

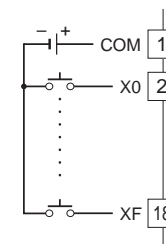

NPN TRANSISTOR OUTPUT EXTENSION MODULE, 8 points

CIRCUIT DIAGRAM

MODEL: R7C-EC8A

SPECIFICATIONS

- Common:** Negative common (NPN) per 8 points
- Number of I/O:** Output, 8 points
- Maximum outputs applicable at once:** No limit (at 24 V DC)
- I/O status indicator:** LED turns on with closed contact.
- Isolation:** Output to internal circuits
- Rated load voltage:** 24 V DC $\pm 10\%$
- Rated output current:** 0.25 A per point, 2.0 A per common
- Residual voltage:** ≤ 1.2 V
- Leakage current:** ≤ 0.1 mA
- ON delay:** ≤ 0.5 msec.
- OFF delay:** ≤ 1.5 msec.

TERMINAL ASSIGNMENTS

6	7	8	9	10
+24 V	Y1	Y3	Y5	Y7
1	2	3	4	5
0 V	Y0	Y2	Y4	Y6

NO.	ID	FUNCTION	NO.	ID	FUNCTION
1	0 V	0 V (common)	6	+24 V	24 V DC
2	Y0	Output 0	7	Y1	Output 1
3	Y2	Output 2	8	Y3	Output 3
4	Y4	Output 4	9	Y5	Output 5
5	Y6	Output 6	10	Y7	Output 7

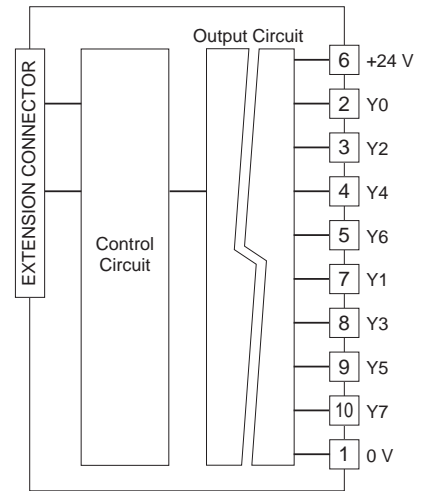

Output Circuit

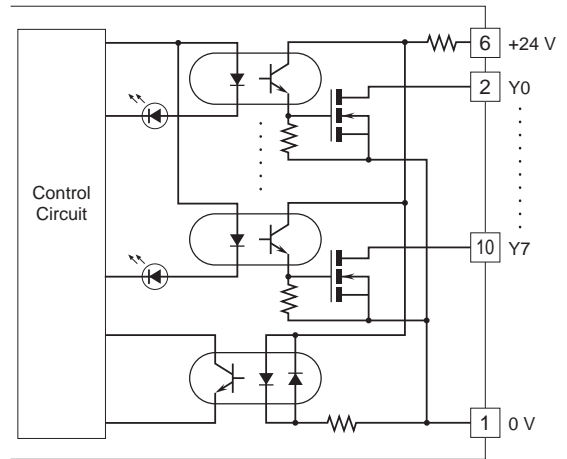

Output Connection Example

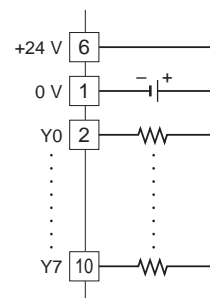

NPN TRANSISTOR OUTPUT EXTENSION MODULE, 16 points

CIRCUIT DIAGRAM

MODEL: R7C-EC16A

SPECIFICATIONS

- Common:** Negative common (NPN) per 16 points
- Number of I/O:** Output, 16 points
- Maximum outputs applicable at once:** No limit (at 24 V DC)
- I/O status indicator:** LED turns on with closed contact.
- Isolation:** Output to internal circuits
- Rated load voltage:** 24 V DC $\pm 10\%$
- Rated output current:** 0.25 A per point, 2.0 A per common
- Residual voltage:** ≤ 1.2 V
- Leakage current:** ≤ 0.1 mA
- ON delay:** ≤ 0.5 msec.
- OFF delay:** ≤ 1.5 msec.

TERMINAL ASSIGNMENTS

10	11	12	13	14	15	16	17	18
+24 V	Y1	Y3	Y5	Y7	Y9	YB	YD	YF
1	2	3	4	5	6	7	8	9
0 V	Y0	Y2	Y4	Y6	Y8	YA	YC	YE

NO.	ID	FUNCTION	NO.	ID	FUNCTION
1	0 V	0 V (common)	10	+24 V	24 V DC
2	Y0	Output 0	11	Y1	Output 1
3	Y2	Output 2	12	Y3	Output 3
4	Y4	Output 4	13	Y5	Output 5
5	Y6	Output 6	14	Y7	Output 7
6	Y8	Output 8	15	Y9	Output 9
7	YA	Output 10	16	YB	Output 11
8	YC	Output 12	17	YD	Output 13
9	YE	Output 14	18	YF	Output 15

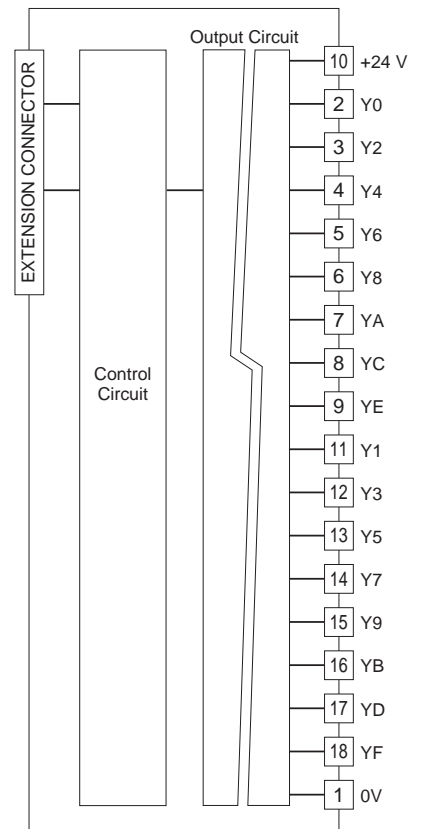

Output Circuit

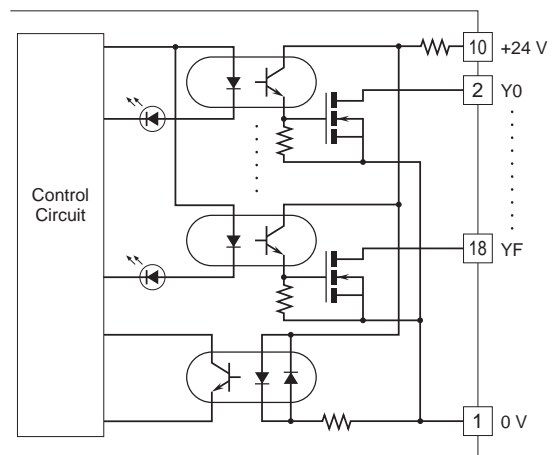

Output Connection Example

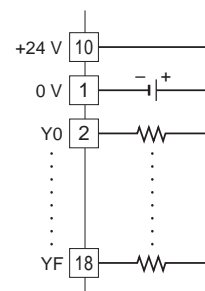

PNP TRANSISTOR OUTPUT EXTENSION MODULE, 8 points

CIRCUIT DIAGRAM

MODEL: R7C-EC8B

SPECIFICATIONS

- Common:** Positive common (PNP) per 8 points
- Number of I/O:** Output, 8 points
- Maximum outputs applicable at once:** No limit (at 24 V DC)
- I/O status indicator:** LED turns on with closed contact.
- Isolation:** Output to internal circuits
- Rated load voltage:** 24 V DC $\pm 10\%$
- Rated output current:** 0.25 A per point, 2.0 A per common
- Residual voltage:** ≤ 1.2 V
- Leakage current:** ≤ 0.1 mA
- ON delay:** ≤ 0.5 msec.
- OFF delay:** ≤ 1.5 msec.

TERMINAL ASSIGNMENTS

6	7	8	9	10
+24 V	Y1	Y3	Y5	Y7
1	2	3	4	5
0 V	Y0	Y2	Y4	Y6

NO.	ID	FUNCTION	NO.	ID	FUNCTION
1	0 V	0 V	6	+24 V	24 V DC (common)
2	Y0	Output 0	7	Y1	Output 1
3	Y2	Output 2	8	Y3	Output 3
4	Y4	Output 4	9	Y5	Output 5
5	Y6	Output 6	10	Y7	Output 7

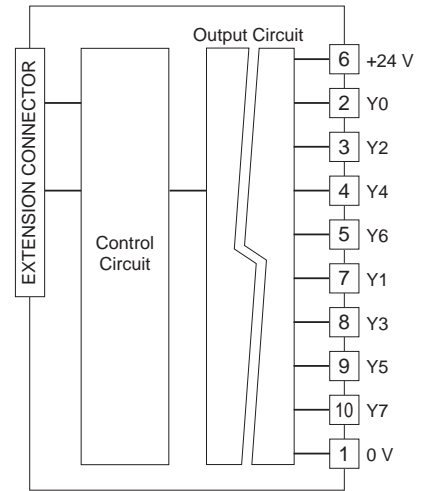

Output Circuit

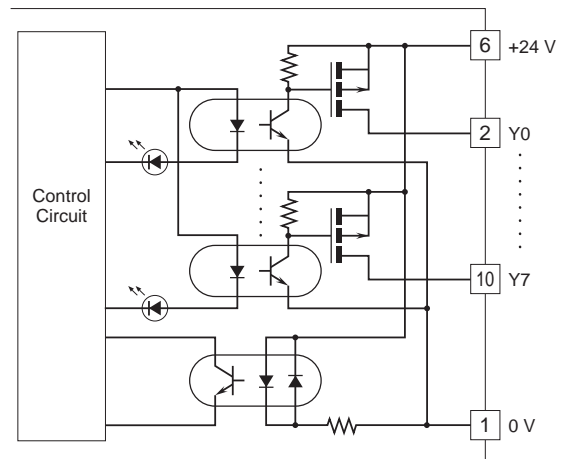

Output Connection Example

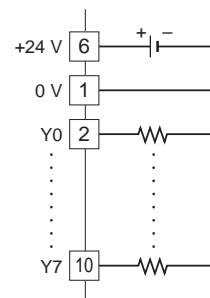

PNP TRANSISTOR OUTPUT EXTENSION MODULE, 16 points

CIRCUIT DIAGRAM

MODEL: R7C-EC16B

SPECIFICATIONS

- Common:** Positive common (PNP) per 16 points
- Number of I/O:** Output, 16 points
- Maximum outputs applicable at once:** No limit (at 24 V DC)
- I/O status indicator:** LED turns on with closed contact.
- Isolation:** Output to internal circuits
- Rated load voltage:** 24 V DC $\pm 10\%$
- Rated output current:** 0.25 A per point, 2.0 A per common
- Residual voltage:** ≤ 1.2 V
- Leakage current:** ≤ 0.1 mA
- ON delay:** ≤ 0.5 msec.
- OFF delay:** ≤ 1.5 msec.

TERMINAL ASSIGNMENTS

10	11	12	13	14	15	16	17	18
+24 V	Y1	Y3	Y5	Y7	Y9	YB	YD	YF
1	2	3	4	5	6	7	8	9
0 V	Y0	Y2	Y4	Y6	Y8	YA	YC	YE

NO.	ID	FUNCTION	NO.	ID	FUNCTION
1	0 V	0 V	10	+24 V	24 V DC (common)
2	Y0	Output 0	11	Y1	Output 1
3	Y2	Output 2	12	Y3	Output 3
4	Y4	Output 4	13	Y5	Output 5
5	Y6	Output 6	14	Y7	Output 7
6	Y8	Output 8	15	Y9	Output 9
7	YA	Output 10	16	YB	Output 11
8	YC	Output 12	17	YD	Output 13
9	YE	Output 14	18	YF	Output 15

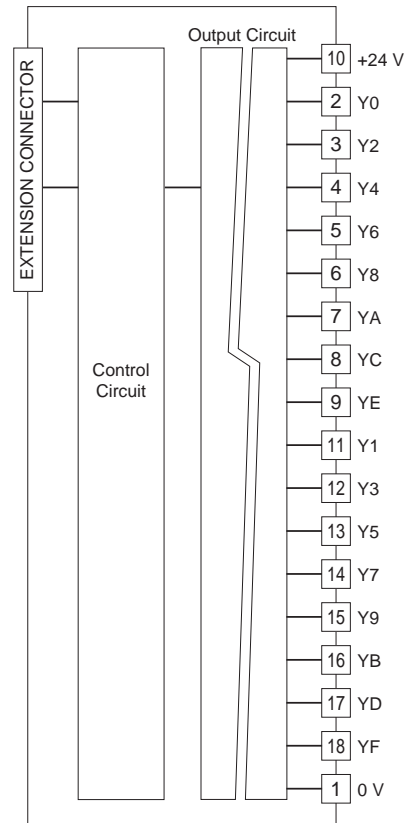

Output Circuit

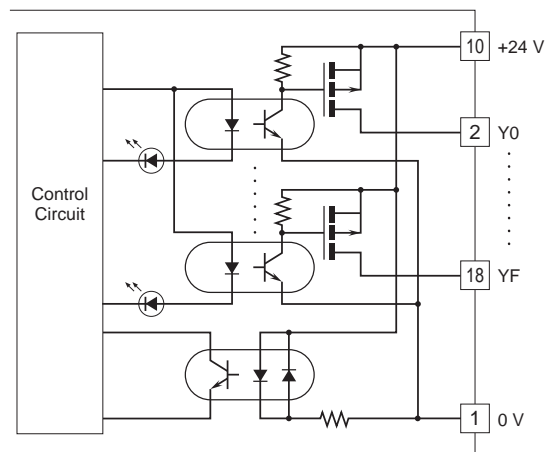

Output Connection Example

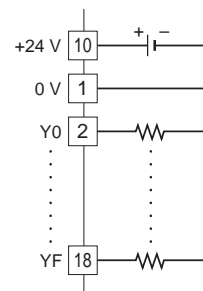

RELAY CONTACT OUTPUT EXTENSION MODULE

CIRCUIT DIAGRAM

MODEL: R7C-EC8C

SPECIFICATIONS

- Common:** 1 common per 4 points (4 terminals)
 - Common current:** Max. 8 A (4 terminals)
 - Number of I/O:** Relay contact output, 8 points
 - Maximum outputs applicable at once:** No limit (at 24 V DC)
 - I/O status indicator:** LED turns on with closed contact.
 - Isolation:** Output to internal circuits
 - Relay driving power:** 24 V DC $\pm 10\%$, ≥ 60 mA
 - Rated load:** 250 V AC* @2 A ($\cos \phi = 1$)
30 V DC @2 A (resistive load)
 - Electrical life 10^5 cycles (rate 30/min.)
 - *When it is used as a product relevant to EC directive, it should be used under the Installation Category I, 125 V AC or less.
 - Maximum switching voltage:** 250 V AC or 30 V DC
 - Maximum switching power:** 500 VA or 60 W
 - Minimum load:** 24 V DC @5 mA
 - Mechanical life:** 2×10^7 cycles (rate 300/min.)
- When driving an inductive load, external contact protection and noise quenching are recommended.
- ON delay:** ≤ 10 msec.
 - OFF delay:** ≤ 10 msec.

TERMINAL ASSIGNMENTS

10	11	12	13	14	15	16	17	18
+24 V	Y0	Y1	Y2	Y3	Y4	Y5	Y6	Y7
1	2	3	4	5	6	7	8	9
0 V	COM0	COM0	COM0	COM0	COM1	COM1	COM1	COM1

NO.	ID	FUNCTION	NO.	ID	FUNCTION
1	0 V	0 V	10	+24 V	24 V DC
2	COM0	Common 0	11	Y0	Output 0
3	COM0	Common 0	12	Y1	Output 1
4	COM0	Common 0	13	Y2	Output 2
5	COM0	Common 0	14	Y3	Output 3
6	COM1	Common 1	15	Y4	Output 4
7	COM1	Common 1	16	Y5	Output 5
8	COM1	Common 1	17	Y6	Output 6
9	COM1	Common 1	18	Y7	Output 7

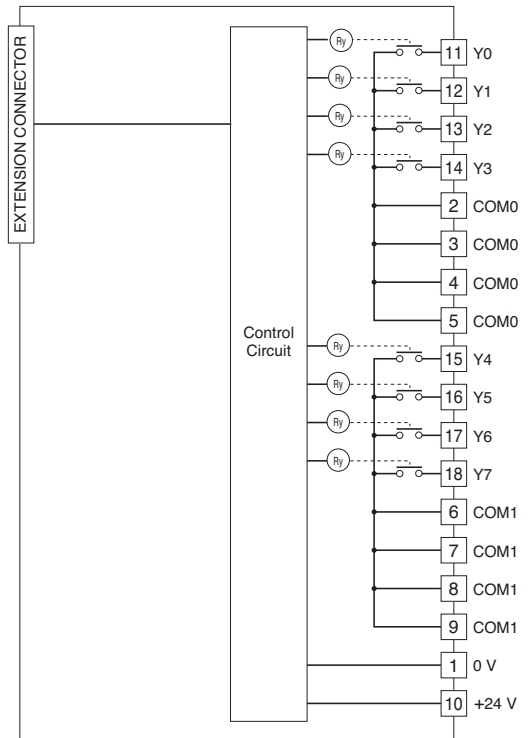

Output Connection Example

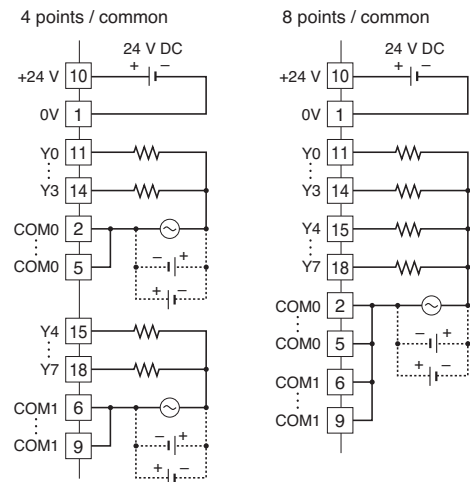



Specifications are subject to change without notice.

