

Remote I/O R5 Series

PULSE OUTPUT MODULE

(screw terminal block; photo MOSFET relay output, 2 points)

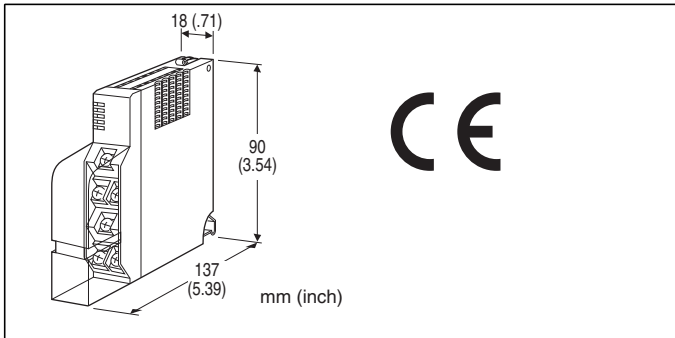

MODEL: R5T-PC2[1][2]

ORDERING INFORMATION

- Code number: R5T-PC2[1][2]
Specify a code from below for each [1] and [2].
(e.g. R5T-PC2W/Q)
- Specify the specification for option code /Q
(e.g. /C01/S01)

[1] COMMUNICATION MODE

S: Single
W: Dual

[2] OPTIONS

blank: none
/Q: With options (specify the specification)

SPECIFICATIONS OF OPTION: Q (multiple selections)

COATING (For the detail, refer to M-System's web site.)

- /C01: Silicone coating
- /C02: Polyurethane coating
- /C03: Rubber coating

TERMINAL SCREW MATERIAL

/S01: Stainless steel

GENERAL SPECIFICATIONS

Connection

- Internal bus:** Via the Installation Base
(model: R5-BSx)
- Output:** M3.5 screw terminal block (torque 0.8 N·m)
- Power supply:** Via the base (model: R5-BSx)
- Screw terminal:** Nickel-plated steel (standard) or stainless steel
- Isolation:** Po 1 to Po 2 to internal power

- RUN indicator:** Bi-color (red/green) LED;
Red when the bus A operates normally;
Green when the bus B operates normally;
Amber when both buses operate normally.
- Output status indicator:** Red LED; turns on with the relays energized.
- Pulse width adjustment:** 5 msec., 10 msec., 50 msec., 100 msec., 500 msec., 1 sec., 1.5 sec., 2 sec. (Side DIP SW)
- Count reset:** Via DIP switches on the side

OUTPUT SPECIFICATIONS

- Output:** Photo MOSFET relay contact, 2 points
- Common:** Each point independent
- Rated load:** 125 V AC/DC @ 50 mA (resistive load)
- Maximum ON resistance:** 50 Ω
- Maximum frequency:** 100 Hz (DIP SW selectable)
- Totalized pulse range:** 1 - 10000 ('0' at reset)
(Max. pulse range selectable from 100 to 60000 using the R5CON PC Configurator Software. Refer to the R5CON Users Manual for detailed information.)
- Count at overflow:** Reset and restart at '1.'

INSTALLATION

- Operating temperature:** -10 to +55°C (14 to 131°F)
- Operating humidity:** 30 to 90 %RH (non-condensing)
- Atmosphere:** No corrosive gas or heavy dust
- Mounting:** Installation Base (model: R5-BSx)
- Weight:** 110 g (0.24 lb)

PERFORMANCE

- Data allocation:** 2
- Response time:** ≤ 0.1 sec.
- Insulation resistance:** ≥ 100 MΩ with 500 V DC
- Dielectric strength:** 1500 V AC @ 1 minute
(Po 1 to Po 2 to internal power)
2000 V AC @ 1 minute (power input to FG;
isolated on the power supply module)

STANDARDS & APPROVALS

- CE conformity:**
EMC Directive (2004/108/EC)
EMI EN 61000-6-4: 2007
EMS EN 61000-6-2: 2005
Low Voltage Directive (2006/95/EC)
EN 61010-1: 2001
Measurement Category II
Pollution Degree 2
Contact output to internal power - Basic insulation
(300 V)



FUNCTIONS

■ Counter reset

- 1) Remove Network Module or its cables and interrupt communication with other devices.
- 2) Turn ON the Counter Reset SW (DIP SW8) on R5-PC2 module.
- 3) Return the module to the base and turn the power supply on.
- 4) Red RUN LED turns on and the module starts resetting its counter. When the resetting is complete, the LED light turns to green. DO NOT remove the power while the red light is on.
- 5) After the green LED is confirmed, turn the power supply off.
- 6) Turn OFF the Counter Reset SW (DIP SW8).
- 7) Return the Network module onto the base and turn the power supply on.

Note: Counter Reset SW must be turned OFF after this procedure because the module does not start counting with ON state.

EXTERNAL VIEW

■ SIDE VIEW

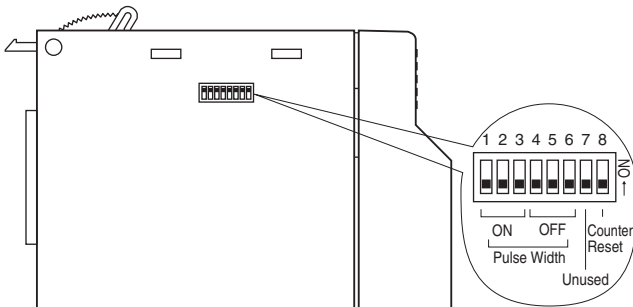

Counter Reset SW is normally OFF during operation.

■ FRONT VIEW

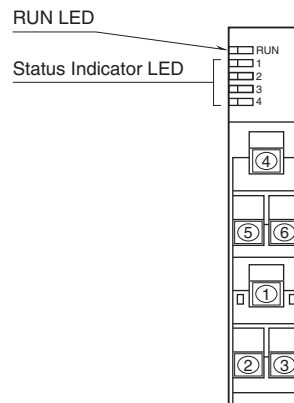

EXTERNAL DIMENSIONS & TERMINAL ASSIGNMENTS unit: mm (inch)

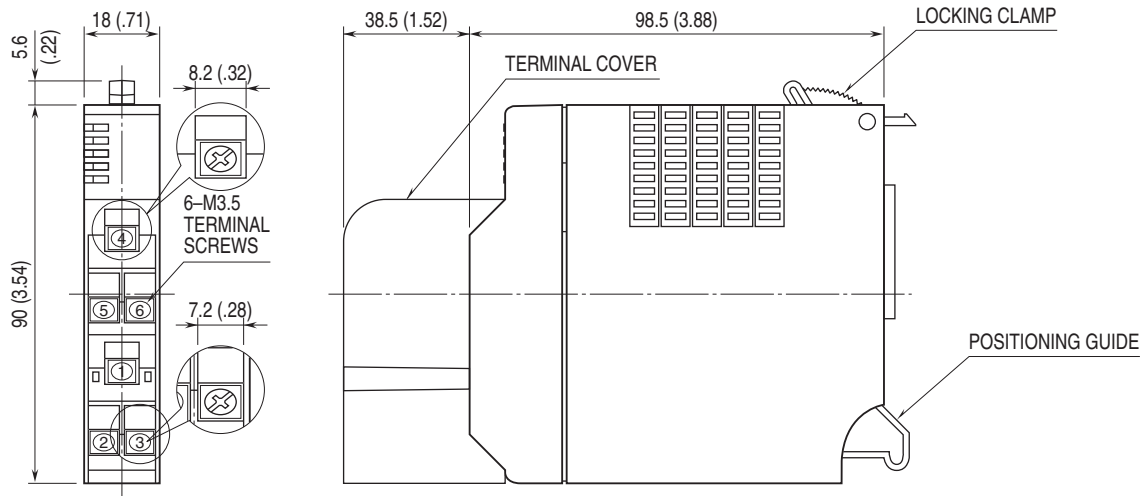

SCHEMATIC CIRCUITRY & CONNECTION DIAGRAM

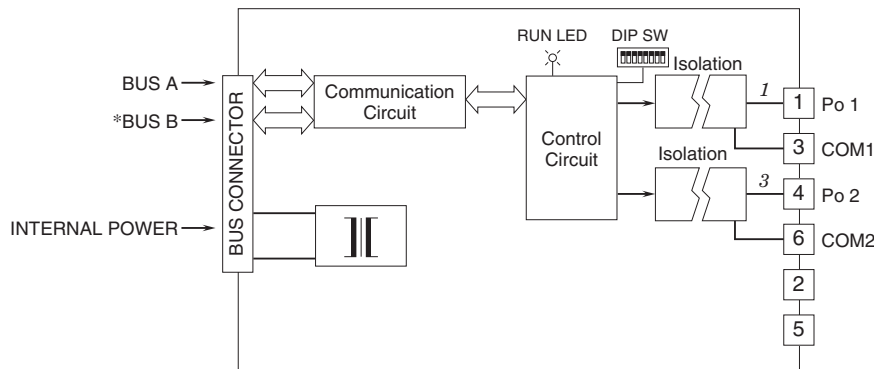

*For dual redundant communication.

NOTE: Italic typed numbers correspond to the LEDs on the front panel.



Specifications are subject to change without notice.