

Remote I/O R5 Series

RTD INPUT MODULE

(re-transmitted output)

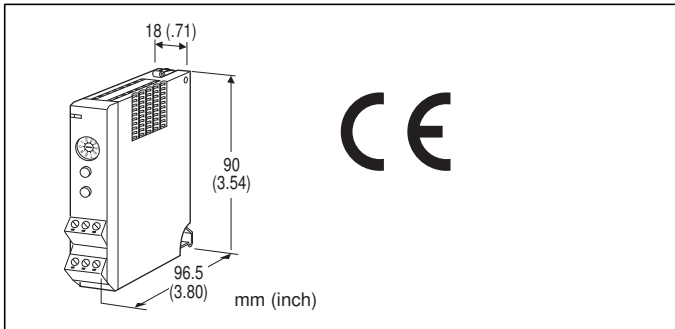

MODEL: R5-RS1A[1][2]

ORDERING INFORMATION

- Code number: R5-RS1A[1][2]
Specify a code from below for each [1] and [2].
(e.g. R5-RS1AW/Q)
- Specify the specification for option code /Q
(e.g. /C01)

NO. OF CHANNELS

1: 1 channel

OUTPUT

Current

A: 4 - 20 mA DC (Load resistance 600 Ω max.)

[1] COMMUNICATION MODE

S: Single

W: Dual

[2] OPTIONS

blank: none

/Q: With options (specify the specification)

SPECIFICATIONS OF OPTION: Q

COATING (For the detail, refer to M-System's web site.)

/C01: Silicone coating

/C02: Polyurethane coating

/C03: Rubber coating

GENERAL SPECIFICATIONS

Connection

Internal bus: Via the Installation Base

(model: R5-BS)

I/O: Euro type connector terminal

Wire size AWG24-12 (0.2 - 2.5 mm²), stripped length 7 mm

Internal power: Via the base (model: R5-BS)

Isolation: Input to output to internal bus or internal power

Zero/Span adj. mode selector: Rotary switch; monitor mode, adj. mode and simulated output mode selectable

Sensor type: Selectable with the side DIP SW

Temperature unit: °C, °F or absolute temperature selectable with the side DIP SW

Burnout detection: Upscale or downscale selectable with the side DIP SW

Linearization: Standard

RUN indicator: Bi-color (red/green) LED;

Red when the bus A operates normally;

Green when the bus B operates normally;

Amber when both buses operate normally.

INPUT SPECIFICATIONS

Maximum leadwire resistance: 200 Ω per wire (3-wire)

Sensing current: ≤ 1 mA

Temperature range

RTD	°C	
	USABLE RANGE	CONFORMANCE RANGE
Cu 10 @25°C	-212 to +312	-50 to +250
Cu 50	-100 to +200	-50 to +150
JPt 100 (JIS '89)	-236 to +560	-200 to +510
Pt 100 (JIS '89)	-240 to +900	-200 to +660
Pt 100 (JIS '97, IEC) (*)	-240 to +900	-200 to +850
Pt 1000	-240 to +900	-200 to +850
Pt 50Ω (JIS '81)	-236 to +700	-200 to +649
Ni 100	-100 to +252	-80 to +250
Ni 508.4Ω	-100 to +332	-50 to +200
RTD	°F	
	USABLE RANGE	CONFORMANCE RANGE
Cu 10 @25°C	-350 to +594	-58 to +482
Cu 50	-148 to +392	-58 to +302
JPt 100 (JIS '89)	-393 to +1040	-328 to +950
Pt 100 (JIS '89)	-400 to +1652	-328 to +1220
Pt 100 (JIS '97, IEC)	-400 to +1652	-328 to +1562
Pt 1000	-400 to +1652	-328 to +1562
Pt 50Ω (JIS '81)	-393 to +1292	-328 to +1200
Ni 100	-148 to +486	-112 to +482
Ni 508.4Ω	-148 to +630	-58 to +392

(*) Factory setting. Set the input range within 0-1000°C corresponding to the output range 0-10000.

Max. (upscale) or min. (downscale) value of the usable range when a burnout is detected.

OUTPUT SPECIFICATIONS

Operational range: Approx. 0 - 24 mA DC



INSTALLATION

Operating temperature: -10 to +55°C (14 to 131°F)
Operating humidity: 30 to 90 %RH (non-condensing)
Atmosphere: No corrosive gas or heavy dust
Mounting: Installation Base (model: R5-BS)
Weight: 100 g (3.53 oz)

- 1) Start up in Monitor Mode (SW position = 0) and wait for 2 or 3 seconds.
- 2) Switch to another mode and go through the adjustments.
- 3) Reset the switch to the position '0' so that the new setting is stored in the internal memory.

PERFORMANCE

Conversion accuracy

Input: $\pm 0.4^{\circ}\text{C}$ ($\pm 3.0^{\circ}\text{C}$ for Cu 10)

Output: $\pm 0.1\%$ of the retransmitted range + input

conversion accuracy

(May exceed $\pm 0.1\%$ depending upon the input temperature range.)

Conversion data: Temperature data scaled and converted into 0 - 100 % data and supplied to the internal network bus

Data allocation: 1

Temp. coefficient

Input: $\pm 0.015\%/^{\circ}\text{C}$ ($\pm 0.008\%/^{\circ}\text{F}$)

Output: $\pm 0.02\%/^{\circ}\text{C}$ ($\pm 0.01\%/^{\circ}\text{F}$)

Response time: ≤ 0.4 sec. (0 - 90 %)

Burnout response time: ≤ 2 sec.

Insulation resistance: $\geq 100\ \text{M}\Omega$ with 500 V DC

Dielectric strength: 1500 V AC @ 1 minute (input to output to internal bus or internal power)

2000 V AC @ 1 minute (power input to FG; isolated on the power supply module)

STANDARDS & APPROVALS

CE conformity:

EMC Directive (2004/108/EC)

EMI EN 61000-6-4: 2007/A1: 2011

EMS EN 61000-6-2: 2005

FUNCTIONS

• Zero/Span Adjustment Modes

Monitor Mode

Re-transmits the input signal as output in proportion.

Output 0 % Adjustment Mode

Adjusts the 0 % output signal using the front UP/DOWN buttons, in monitoring the output value with a multimeter. SW1 through SW3 switch the internal increments by 1, 5 and 10.

Output 100 % Adjustment Mode

Adjusts the 100 % output signal using the front UP/DOWN buttons, in monitoring the output value with a multimeter. SW4 through SW6 switch the internal increments by 1, 5 and 10.

Simulated Output Mode

Outputs the simulated signals of 0 %, 50 % and 100 %.

• How to Operate



EXTERNAL VIEW

■ SIDE VIEW

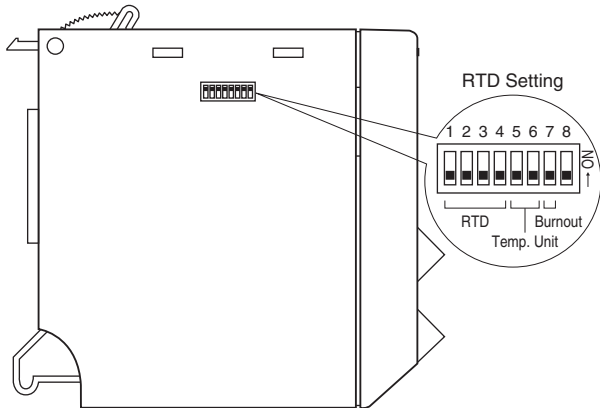

■ FRONT VIEW

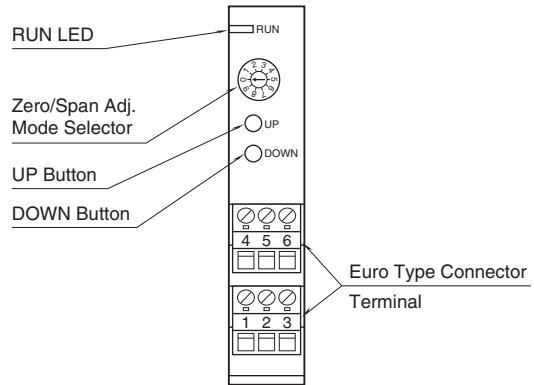

EXTERNAL DIMENSIONS & TERMINAL ASSIGNMENTS unit: mm (inch)

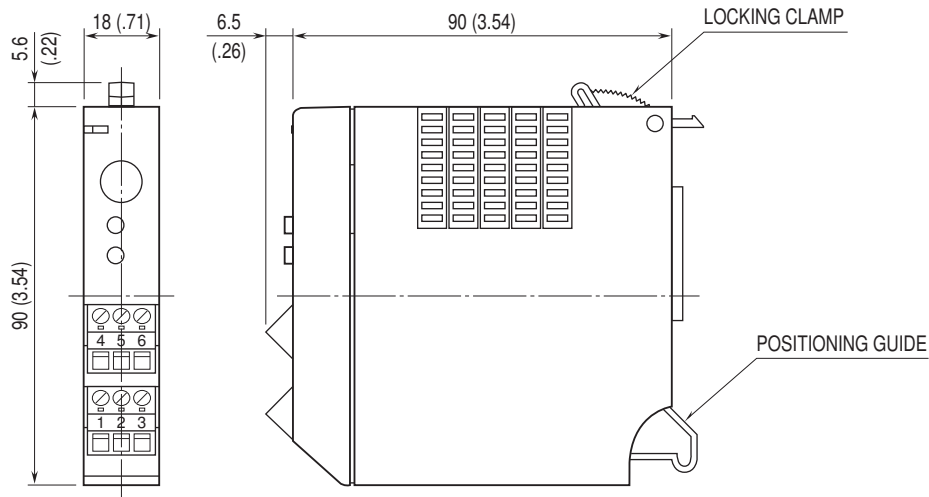

SCHEMATIC CIRCUITRY & CONNECTION DIAGRAM

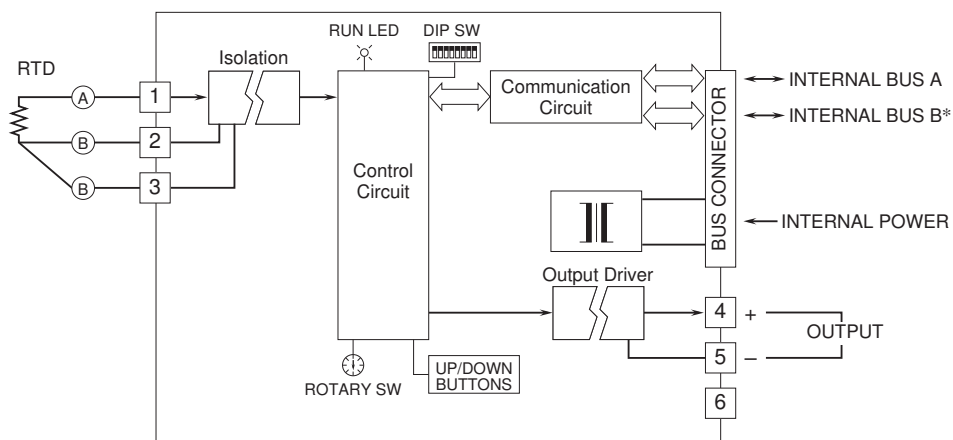

*For dual redundant communication.



Specifications are subject to change without notice.



幸託有限公司
XIN TOP CORPORATION

TEL : (02)2598-1199
FAX : (02)2596-2331

E-mail : info@xintop.com
Website : www.xintop.com