

Remote I/O R5 Series

TOTALIZED PULSE INPUT MODULE

(Pi 2 points)

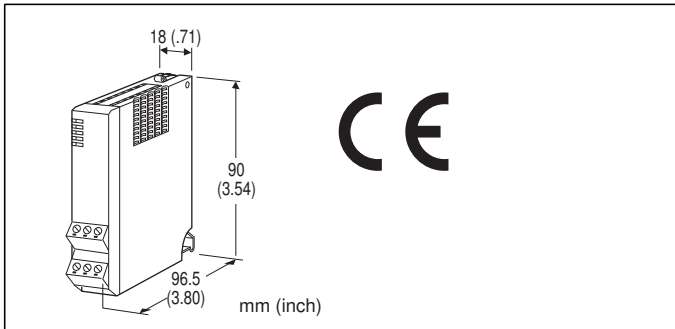

MODEL: R5-PA2[1][2]

ORDERING INFORMATION

- Code number: R5-PA2[1][2]
Specify a code from below for each [1] and [2].
(e.g. R5-PA2W/Q)
- Specify the specification for option code /Q
(e.g. /C01)

[1] COMMUNICATION MODE

S: Single
W: Dual

[2] OPTIONS

blank: none
/Q: With options (specify the specification)

SPECIFICATIONS OF OPTION: Q

COATING (For the detail, refer to M-System's web site.)

- /C01: Silicone coating
- /C02: Polyurethane coating
- /C03: Rubber coating

GENERAL SPECIFICATIONS

Connection

Internal bus: Via the Installation Base
(model: R5-BS)
Input: Euro type connector terminal
Wire size AWG24-12 (0.2 - 2.5 mm²), stripped length 7 mm
Internal power: Via the base (model: R5-BS)
Isolation: Pi 1 to Pi 2 to internal bus or internal power
RUN indicator: Bi-color (red/green) LED;
Red when the bus A operates normally;
Green when the bus B operates normally;

Amber when both buses operate normally.

Input status indicator: Red LED; turns on with the inputs supplied.

Count reset: Via DIP switches on the side

INPUT SPECIFICATIONS

Input: Dry contact, 2 points

Common: All negatives

Contact detecting: Max. 24 V DC

ON current/resistance: ≥ 2.5 mA, ≤ 1 k Ω

OFF current/resistance: ≤ 1 mA, ≥ 10 k Ω

Maximum frequency: 100 Hz (duty ratio 30 - 70 %)

Totalized pulse range: 1 - 10000 ('0' at reset)

Max. pulse range selectable from 100 to 60000 using the R5CON PC Configurator Software. Refer to the R5CON Users Manual for detailed information.

Count at overflow: Reset and restart at '1.'

INSTALLATION

Operating temperature: -10 to +55°C (14 to 131°F)

Operating humidity: 30 to 90 %RH (non-condensing)

Atmosphere: No corrosive gas or heavy dust

Mounting: Installation Base (model: R5-BS)

Weight: 100 g (3.53 oz)

PERFORMANCE

Data allocation: 2

Response time: ≤ 0.1 sec.

Insulation resistance: ≥ 100 M Ω with 500 V DC

Dielectric strength: 1500 V AC @ 1 minute

(Pi 1 to Pi 2 to internal bus or internal power)

2000 V AC @ 1 minute (power input to FG; isolated on the power supply module)

STANDARDS & APPROVALS

CE conformity:

EMC Directive (2004/108/EC)

EMI EN 61000-6-4: 2007/A1: 2011

EMS EN 61000-6-2: 2005

FUNCTIONS

■ Counter Reset

- 1) Remove Network Module or its cables and interrupt communication with other devices.
- 2) Turn ON the Counter Reset SW (DIP SW8) on R5-PA2 module.
- 3) Return the module to the base and turn the power supply on.
- 4) Red RUN LED turns on and the module starts resetting its counter. When the resetting is complete, the LED light turns



to green. DO NOT remove the power while the red light is on.

5) After the green LED is confirmed, turn the power supply off.

6) Turn OFF the Counter Reset SW (DIP SW8).

7) Return the Network module onto the base and turn the power supply on.

Note: Counter Reset SW must be turned OFF after this procedure because the module does not start counting with ON state.

EXTERNAL VIEW

■ SIDE VIEW

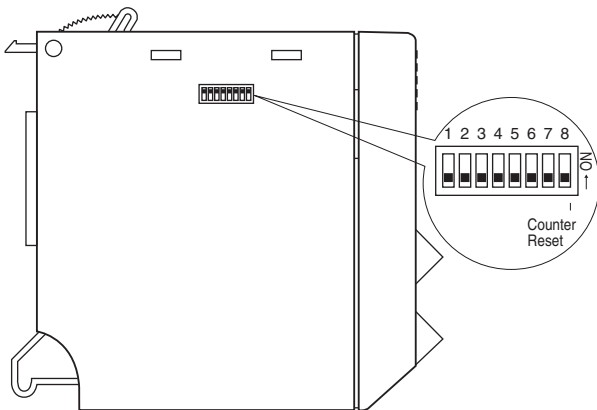

Counter Reset SW is normally OFF during operation.

■ FRONT VIEW

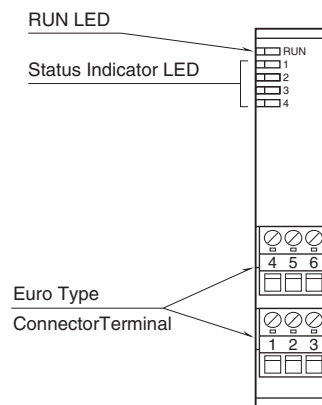

EXTERNAL DIMENSIONS & TERMINAL ASSIGNMENTS unit: mm (inch)

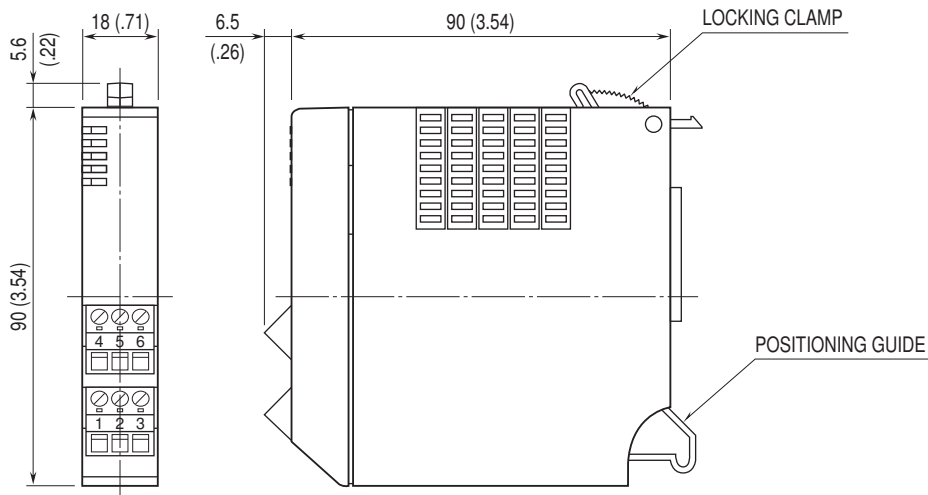

SCHEMATIC CIRCUITRY & CONNECTION DIAGRAM

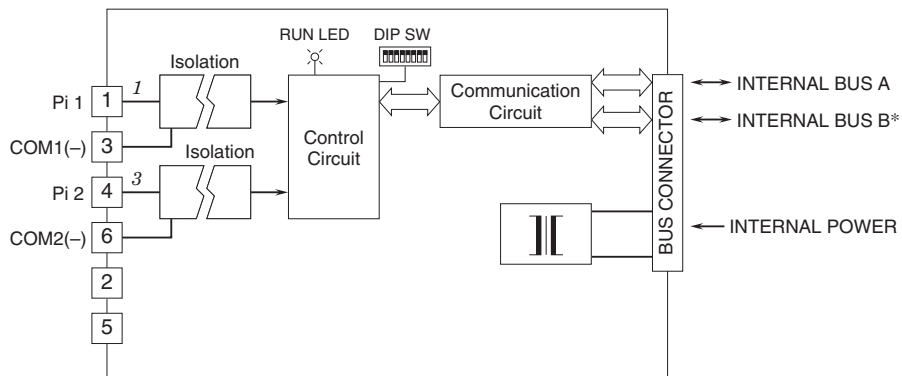

*For dual redundant communication.
NOTE: Italic typed numbers correspond to the LEDs on the front panel.



Specifications are subject to change without notice.

