

Remote I/O R5 Series

T-Link INTERFACE MODULE

(Fuji Electric T-Link use)

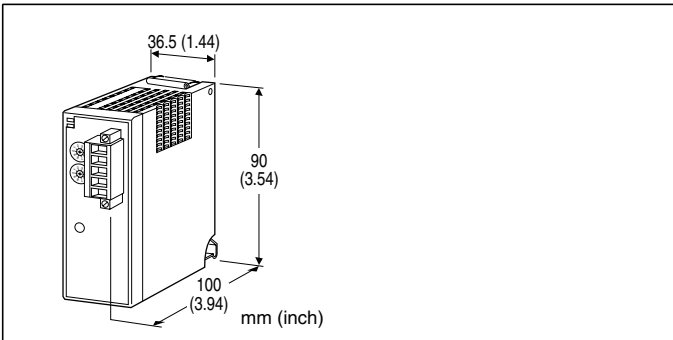

MODEL: R5-NF1[1]

ORDERING INFORMATION

- Code number: R5-NF1[1]

Specify a code from below for [1].

- (e.g. R5-NE1/Q)
- Specify the specification for option code /Q (e.g. /C01)

[1] OPTIONS

blank: none

/Q: With options (specify the specification)

SPECIFICATIONS OF OPTION: Q

COATING (For the detail, refer to M-System's web site.)

- /C01: Silicone coating
- /C02: Polyurethane coating
- /C03: Rubber coating

GENERAL SPECIFICATIONS

Connection

T-Link: Euro type connector terminal

Wire size AWG24-12 (0.2 - 2.5 mm²), stripped length 7 mm

Internal bus: Via the Installation Base (model: R5-BS)

Internal Power: Via the base (model: R5-BS)

Isolation: T-Link to internal bus or internal power

RUN indicator: Bi-color (green/red) LED; green in normal communications; red when receiving (Function selected with DIP SW3)

ERR indicator: Bi-color (green/red) LED; the green ON/blinks in communication errors; red when transmitting (Function selected with DIP SW3)

Data allocation: Mode 1 or 2 set with the side DIP switch

DIP SW other functions

- I/O points
 - Input or output or I/O mixed
- Refer to the instruction manual for details.

T-LINK SPECIFICATIONS

Node address: Rotary switch; 00 - 99

Configuration: Multi-drop

Communication: Half-duplex

Baud rate: 500 kbps

Transmission media/distance:

KPEV-SB, 0.75 mm² × 1 pair, 700 m

T-KPEV-SB, 1.25 mm² × 1 pair, 1000 m

INSTALLATION

Operating temperature: -10 to +55°C (14 to 131°F)

Operating humidity: 30 to 90 %RH (non-condensing)

Atmosphere: No corrosive gas or heavy dust

Mounting: Installation Base (model: R5-BS)

Weight: 150 g (0.33 lb)

PERFORMANCE

Insulation resistance: ≥ 100 MΩ with 500 V DC

Dielectric strength: 500 V AC @ 1 minute (T-Link to internal bus or internal power)



EXTERNAL VIEW

■ SIDE VIEW

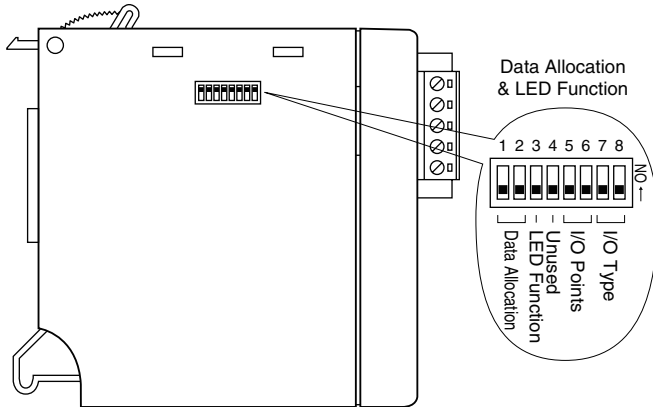

■ FRONT VIEW

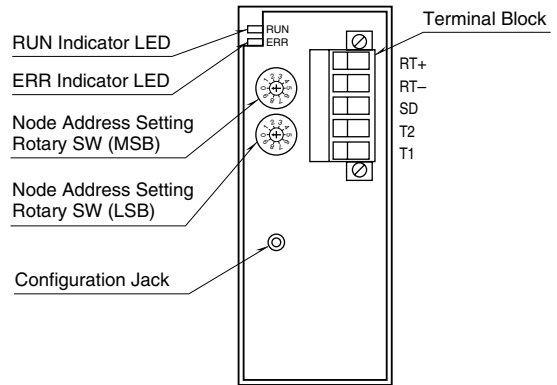

TRANSMISSION DATA DESCRIPTIONS

The DIP SW located at the side of the module switches the unit's data allocation mode.

The Data Allocation Mode 1 is used when all analog I/O modules are single-channel types. In this mode, one (1) word is assigned for one I/O module. The second channel on the dual-channel modules cannot be used.

The Data Allocation Mode 2 is used when one or more analog I/O modules are dual-channel types. In this mode, two (2) words are assigned for one I/O module regardless of whether the second word area is required or not. For example, discrete I/O modules require only one (1) word, but two (2) words are automatically assigned to these modules.



SW	DATA ALLOCATION MODE	
	2	1
1	OFF	ON
2	OFF	OFF

DATA ALLOCATION MODE 1

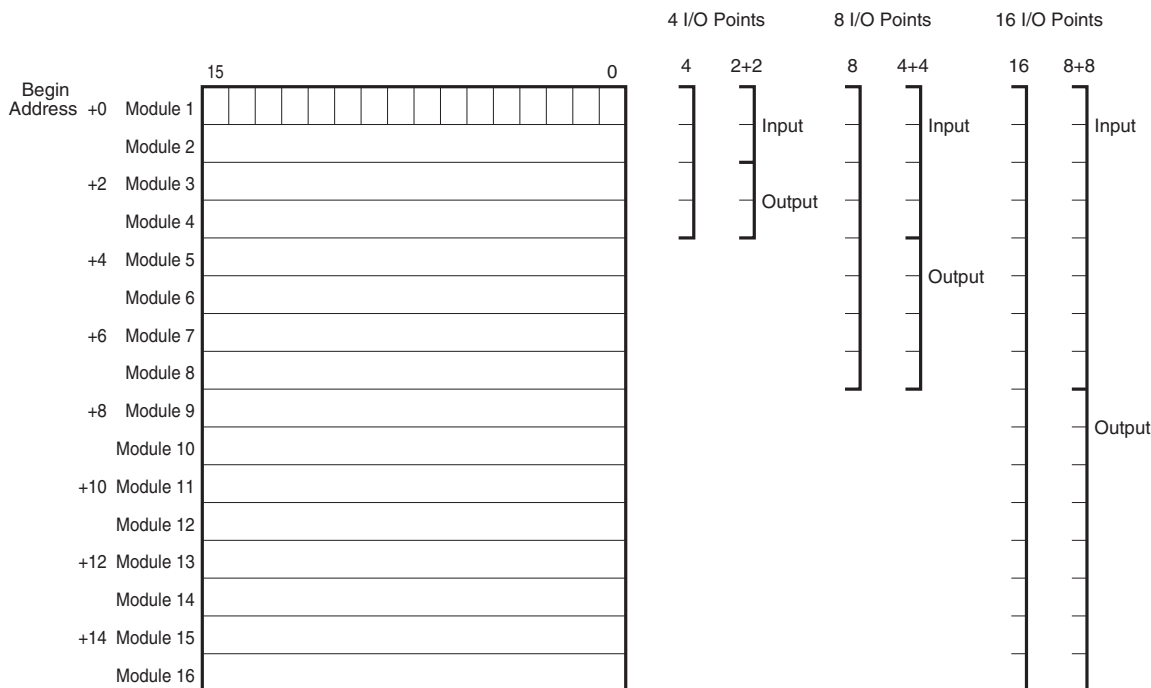

Total number of modules equal the assigned I/O points with Data Allocation Mode 1. I/O modules can be allocated from I/O Module Slot No. 1.

When I/O signals are to be mixed, the former half slots are assigned to the inputs and the latter half are to the outputs. For example, if you have selected '8' I/O points and 'mixed' I/O type, the inputs must be located among I/O Module Slot No. 1 through 4, and the output among No. 5 through 8.

Assigned I/O Points	No. of Modules	Input Modules Only	Output Modules Only	I/O Modules Mixed
4	4	4	4	2 + 2
8	8	8	8	4 + 4
16	16	16	16	8 + 8
64	Not selectable			



DATA ALLOCATION MODE 2

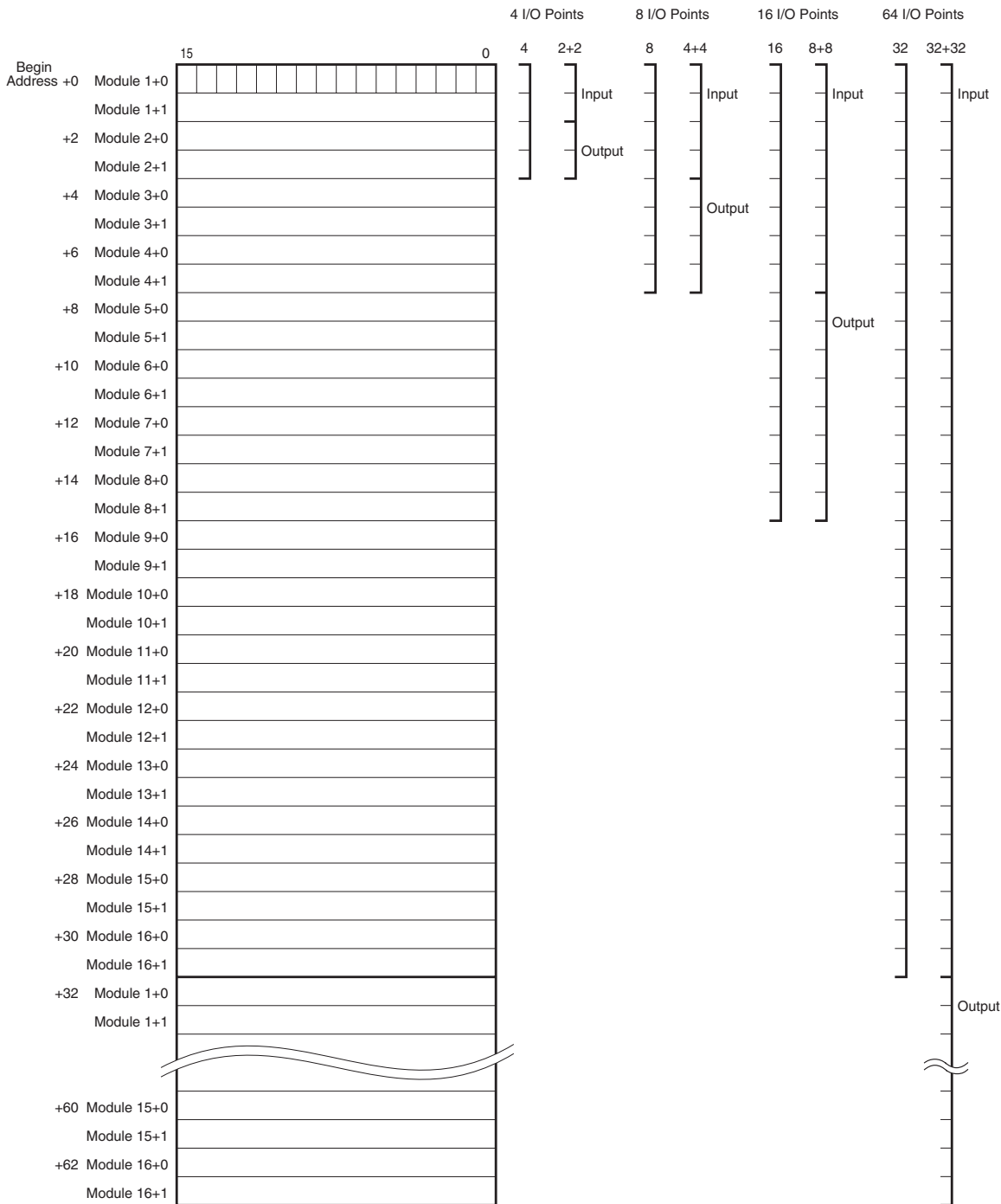

Total number of I/O modules are half the assigned I/O points with Data Allocation Mode 2. I/O modules can be allocated from I/O Module Slot No. 1.

When I/O signals are to be mixed, the former half slots are assigned to the inputs and the latter half are to the outputs. For example, if you have selected '8' I/O points and 'mixed' I/O type, the inputs must be located among I/O Module Slot No. 1 through 2, and the output among No. 3 through 4.

With 64 I/O points assigned, the latter half (32 points) is not used with 'Input Modules Only' or 'Output Modules Only' type, even though these areas are reserved in the PLC's data area.

With '64 I/O points' assigned and 'I/O Modules Mixed' type, the former 32 points (32 words) are assigned to the input and the latter 32 points (32 words) are to the outputs. Only with this setting, I/O modules can be mixed and located in any slots.

Assigned I/O Points	No. of Modules	Input Modules Only	Output Modules Only	I/O Modules Mixed
4	2	4	4	2 + 2
8	4	8	8	4 + 4
16	8	16	16	8 + 8
64	16	32	32	32 + 32



I/O DATA DESCRIPTIONS

■ ANALOG DATA

0 to 100% of the selected I/O range is converted into 0 to 10000 (binary).

With °C temperature unit, raw data is multiplied by 10. For example, 25.5°C is converted into 255.

With °F temperature unit, the integer section of raw data is directly converted into the data. For example, 135.4°F is converted into 135.

Negative values are represented in 2's complements.

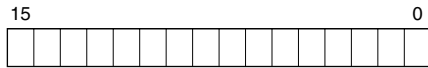

■ 16-POINT DISCRETE DATA

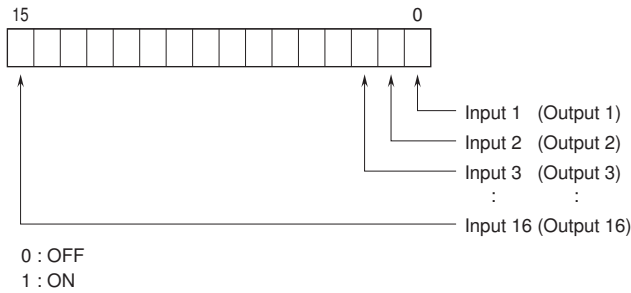

■ 4-POINT DISCRETE DATA

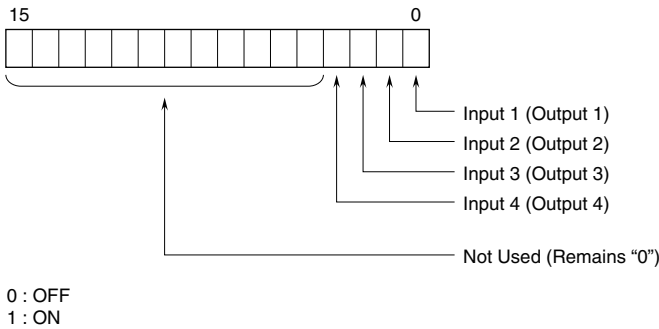

DIMENSIONS unit: mm (inch)

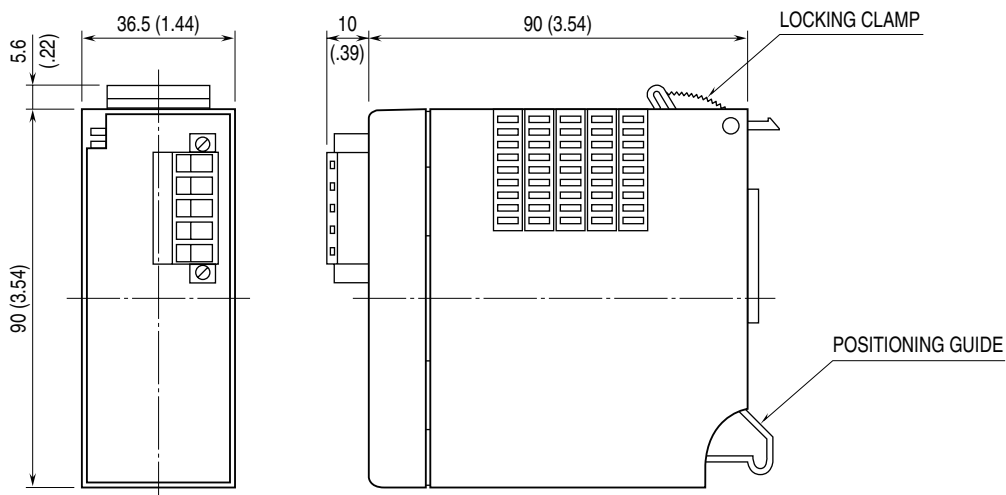

SCHEMATIC CIRCUITRY & CONNECTION DIAGRAM

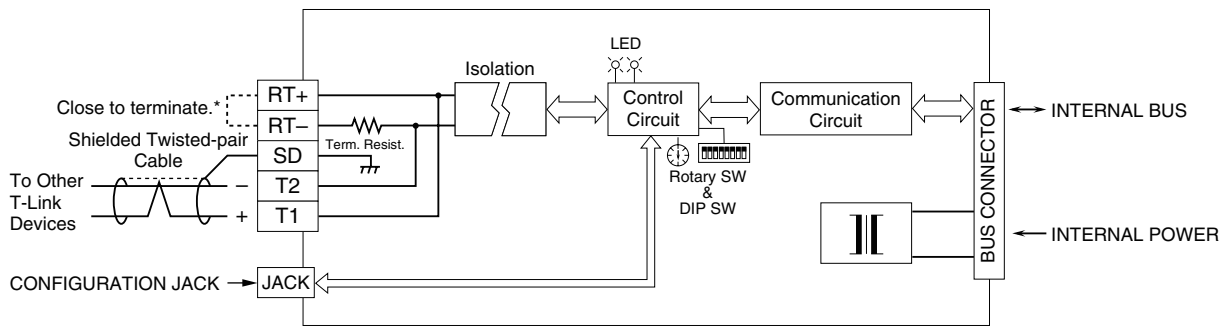

*When the module is at an end of the transmission line via twisted-pair cable (= when there is no cross wiring), close across the RT+ and RT- terminals with the jumper included in the product package. Remove the jumper for all other locations.



Specifications are subject to change without notice.

