

Remote I/O R5 Series

(internal power or internal bus to ground)

EXTENDER POWER MODULE BASE

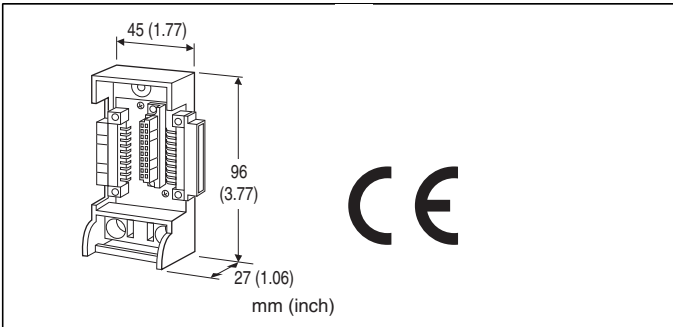

STANDARDS & APPROVALS

CE conformity:

EMC Directive (2004/108/EC)

EMI EN 61000-6-4: 2007

EMS EN 61000-6-2: 2005

MODEL: R5-EX1[1]

ORDERING INFORMATION

- Code number: R5-EX1[1]

Specify a code from below for [1].

(e.g. R5-EX1/Q)

- Specify the specification for option code /Q
(e.g. /C01)

[1] OPTIONS

blank: none

/Q: With options (specify the specification)

SPECIFICATIONS OF OPTION: Q

COATING (For the detail, refer to M-System's web site.)

Only solder side of the main PWB is coated.

/C01: Silicone coating

/C02: Polyurethane coating

/C03: Rubber coating

GENERAL SPECIFICATIONS

Connection: 20-pin connector

Housing material: Flame-resistant resin (gray)

INSTALLATION

Operating temperature: -10 to +55°C (14 to 131°F)

Operating humidity: 30 to 90 %RH (non-condensing)

Atmosphere: No corrosive gas or heavy dust

Mounting: Surface or DIN rail

Weight: 40 g (1.4 oz)

PERFORMANCE

Insulation resistance: $\geq 100 \text{ M}\Omega$ with 500 V DC

(internal power or internal bus to ground)

Dielectric strength: 2000 V AC @ 1 minute



DIMENSIONS unit: mm (inch)

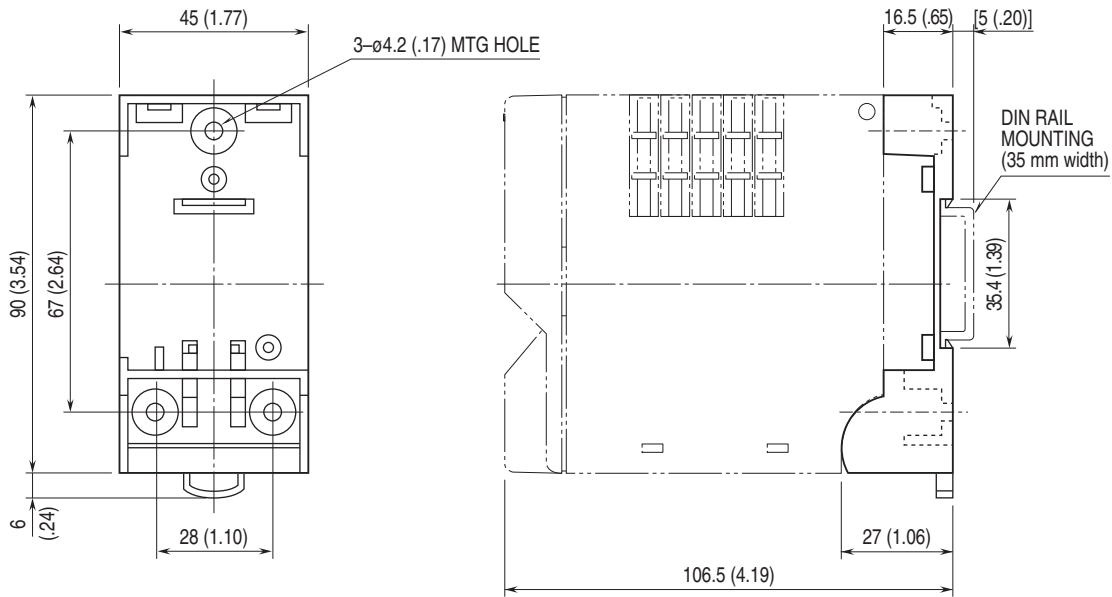

Use an end bracket to secure the connection of the extender base on a DIN rail.



Specifications are subject to change without notice.