

Remote I/O R5 Series

R5 SERIES GENERAL SPECIFICATIONS

Functions & Features

- Free combination of analog and discrete I/O
- Full-isolation between power - communication - I/O and between analog channels
- Various open field bus (DeviceNet, Modbus, etc.)
- Direct sensor inputs
- Dual redundancy in communication and power supply

Typical Applications

- Remote I/O for DCS and PLC
- Personal computer I/O

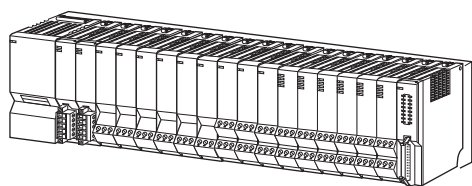

ORDERING INFORMATION

Refer to the specifications of each module for details.

- Network Module: R5-[1]

Specify a code from below for [1].

(e.g. R5-ND1)

- Base or blank filler: R5-[1]

Specify a code from below for [1].

(e.g. R5-BS16)

- I/O Module: R5-[1][2]

Specify a code from below for each [1] and [2].

(e.g. R5-MS2W)

- I/O module with screw terminal block: R5T-[1][2]

Specify a code from below for each [1] and [2].

(e.g. R5T-DC4S)

- Power supply module: R5-[1]

Specify a code from below for [1].

(e.g. R5-PSK)

- PWB coating option is available for model R5T, R5-NM1, R5-BSx, R5-EX and R5-PSx. Refer to the data sheets of each model for detail.

NETWORK MODULES: R5-[1]

[1] MODULE TYPE

NC1: CC-Link

NC2: CC-Link (32-point analog)

ND1: DeviceNet

ND2: DeviceNet (32-point analog)

NE1: Ethernet (Modbus/TCP)

NF1: T-Link

NM1: Modbus

NP1: PROFIBUS-DP

NP2: PROFIBUS-DP (32-point analog)

BASE OR BLANK FILLER: R5-[1]

[1] MODULE TYPE

- Base

BS04: 4 I/O modules

BS05: 5 I/O modules (single communication mode)

BS08: 8 I/O modules

BS09: 9 I/O modules (single communication mode)

BS16: 16 I/O modules

EX1: Extender base for Power Supply Module

- Blank Filler Module

DM: Blank filler module

I/O MODULE: R5-[1][2]

[1] MODULE TYPE

- I/O

TS1: Thermocouple input, 1 ch.

TS2: Thermocouple input, 2 ch.

RS1: RTD input, 1 ch.

RS2: RTD input, 2 ch.

RSA1: RTD input, 1 ch. (high resolution)

RSA2: RTD input, 2 ch. (high resolution)

SS1: DC current input, 1 ch.

SS2: DC current input, 2 ch.

SV1: DC voltage input, 1 ch.

SV2: DC voltage input, 2 ch.

DS1: 4 - 20mA input with excitation, 1 ch.

DS2: 4 - 20mA input with excitation, 2 ch.

MS1: Potentiometer input, 1 ch.

MS2: Potentiometer input, 2 ch.

YS1: 4 - 20mA output, 1 ch.

YS2: 4 - 20mA output, 2 ch.

YV1: DC voltage output, 1 ch.

YV2: DC voltage output, 2 ch.

DA4: Optical isolation discrete input, 4 ch.

DA16: Optical isolation discrete input, 16 ch.

PA2: Totalized pulse input, 2 ch.

DC4: Relay output, 4 ch.

DC16: Open collector output, 16 ch.

PC2: Pulse output, 2 ch.

- I/O Module with Re-transmitted Output

TS1A: Thermocouple input, 1 ch.

RS1A: RTD input, 1 ch.



SS1A: DC current input, 1 ch.
 SV1A: DC voltage input, 1 ch.
 DS1A: 4 - 20 mA input with excitation, 1 ch.
 MS1A: Potentiometer input, 1 ch.

[2] COMMUNICATION MODE

S: Single
 W: Dual

I/O MODULE WITH SCREW TERMINAL BLOCK: R5T-[1][2]

[1] MODULE TYPE

• I/O Module

TS1: Thermocouple input, 1 ch.
 TS2: Thermocouple input, 2 ch.
 RS1: RTD input, 1 ch.
 RS2: RTD input, 2 ch.
 SS1: DC current input, 1 ch.
 SS2: DC current input, 2 ch.
 SV1: DC voltage input, 1 ch.
 SV2: DC voltage input, 2 ch.
 DS1: 4 - 20mA input with excitation, 1 ch.
 DS2: 4 - 20mA input with excitation, 2 ch.
 YS1: 4 - 20mA output, 1 ch.
 YS2: 4 - 20mA output, 2 ch.
 YV1: DC voltage output, 1 ch.
 YV2: DC voltage output, 2 ch.
 DA4: Optical isolation discrete input, 4 ch.
 PA2: Totalized pulse input, 2 ch.
 DC4: Relay output, 4 ch.
 PC2: Pulse output, 2 ch.
 CT1: CT (AC current) input, 1 ch.
 CT2: CT (AC current) input, 2 ch.
 CTA1: AC current input (clamp-on current sensor), 1 ch.
 CTA2: AC current input (clamp-on current sensor), 2 ch.
 CTB1: AC current input (clamp-on current sensor), 1 ch.
 CTB2: AC current input (clamp-on current sensor), 2 ch.
 PT1: PT (AC voltage) input, 1 ch.
 PT2: PT (AC voltage) input, 2 ch.

[2] COMMUNICATION MODE

S: Single
 W: Dual

POWER SUPPLY MODULE: R5-[1]

[1] POWER INPUT

• DC power

PSR: 24 V DC
 PSK: 100 - 120 V AC

PSL: 200 - 240 V AC

DESCRIPTIONS

■ GENERAL

The R5 Series Remote I/O consists of a power supply module, network interface module(s), I/O module(s) and a backplane (base). An extender base for an additional power supply module is available.

• Power Supply Module

Converts AC or DC power inputs for use in the network modules, I/O modules and for exciting discrete I/O.

• Communication Module

Converts data between the open network fieldbus (DeviceNet, etc.) and the internal communication bus, functioning as a Gateway between two buses.

• I/O Module

Performs A/D conversion of field analog inputs; D/A conversion of data received through the internal bus into analog/discrete outputs.

Temperature input (T/C or RTD) is converted into signed binary data which equals 10 times its engineering unit value (°C). e.g. 25.5°C is converted to 255. The °F data is not multiplied.

0 - 100 % of a DC voltage or current signal is converted into hexadecimal 0000 - 2710 (0 - 10000).

• Base

Backplane with communications and power supply buses. An extender base is available for an additional power supply module for dual redundancy.

The R5-BS04, -BS08 and -BS16 can mount two network modules for either single or dual communication mode.

The R5-BS05 and -BS09 can mount only one network module, for single communication mode use.

■ SINGLE COMMUNICATION MODE

When the single communication mode is employed, the network module receives data from the field bus and sends it to analog/discrete output modules through the internal bus. The output modules convert the data into analog or discrete outputs.

The input modules send out via the internal bus analog or discrete inputs to the network module. The network module outputs the data to the field bus.

■ DUAL COMMUNICATION MODE

A dual redundant communication system can be easily achieved by employing two network modules and using dual communication type I/O modules (model suffix code 'W').

Each I/O module is equipped with two independent communication ports, which are connected to the separate network modules. In normal conditions, output modules receive data from both network modules and output the signal from the preferred communication bus A.

When an error is detected in the fieldbus wiring, network



module, or in the internal bus (comm. time error, data error, etc.), the output is switched to the data from the communication bus B. Then if the bus B is in error, the bus A is checked and used again if it is in normal conditions. If both are in error, the output modules hold the signal and stand by until one of the communications recovers. Input modules continuously respond to request-to-send from the both lines. This secures two independent communications.

Dual mode I/O modules can be used in single mode, while the communication bus B does not operate if single mode modules are used in dual mode.

■ HOT INSERTION/REMOVAL OF I/O MODULES

Each I/O and network module has an independent CPU. Data is renewed by serial communications between modules. Therefore no momentary lapse or bumping of analog output occurs when switching communication buses in the dual communication mode.

Furthermore, removing or replacing modules does not affect other modules on the same backplane. It is possible to replace them without removing the power supply. However, replacing multiple modules at once may greatly change line voltage levels. We recommend that you replace them one by one.

PROFIBUS Standard requires that all outputs be turned off when turning the power supply on. Therefore remove the power before replacing the PROFIBUS modules. (Outputs all OFF for discrete and '0' for analog signals.)

RELATED PRODUCTS

- PC configurator software (model: R5CON)

Downloadable at M-System's web site.

A dedicated cable is required to connect the module to the PC. Please refer to the internet software download site or the users manual for the PC configurator for applicable cable types.

GENERAL SPECIFICATIONS

Connection

Network: Euro type connector terminal

I/O: Terminal block

M3.5 screw terminals (R5T Series; torque 0.8 N·m)

20-pin connector (R5-DA16, R5-DC16)

Power input: M3.5 screw terminals (torque 0.8 N·m)

Housing material: Flame-resistant resin (gray)

■ INTERNAL COMMUNICATION BUS

Read rate: Approx. 50 msec.

■ DATA CONVERSION

Depends upon the type of I/O and ranges.

Temperature input (T/C or RTD) is converted into signed binary data which equals 10 times its engineering unit value

(°C). e.g. 25.5°C is converted to 255. The °F data is not multiplied.

Minus temperature is converted into negative value, represented in 2's complements.

0- 100% of a DC voltage or current signal is converted into hexadecimal 0000 - 2710 (0 - 10000). Within -15 - 0 %, the values are represented in 2's complements.

■ ZERO & SPAN SCALING

When the temperature range must be converted into 0 - 100 %, or when you need to scale 0 - 100 % data, use PC Configurator Software (model: R5CON).

INSTALLATION

Operating temperature: -10 to +55°C (14 to 131°F)

Operating humidity: 30 to 90 %RH (non-condensing)

Atmosphere: No corrosive gas or heavy dust



CURRENT CONSUMPTION

The network and I/O modules operates by the DC voltage (21V, 1.5A) supplied from the power module. Arrange these modules in order that the total current consumed by these modules be within this capacity. If the current consumption exceeds the limit, reduce the number of modules to be supplied from the power module.

R5 SERIES	R5T SERIES	MAX. CURRENT	
		2 CH.	1 CH.
R5-DS	R5T-DS	120mA	80mA
R5-SV	R5T-SV	50mA	50mA
R5-SS	R5T-SS	50mA	50mA
R5-YV	R5T-YV	50mA	50mA
R5-YS	R5T-YS	100mA	80mA
R5-YS/H	R5T-YS/H	---	110mA
R5-TS	R5T-TS	60mA	60mA
R5-RS	R5T-RS	60mA	60mA
R5-RSA	----	60mA	60mA
R5-MS	----	60mA	60mA
---	R5T-CT	50mA	50mA
---	R5T-CTA	50mA	50mA
---	R5T-CTB	50mA	50mA
---	R5T-PT	50mA	50mA
R5-PA2	R5T-PA2	30mA	---
R5-PC2	R5T-PC2	30mA	---
R5-SV1A	---	---	80mA
R5-SS1A	---	---	80mA
R5-DS1A	---	---	120mA
R5-TS1A	---	---	80mA
R5-RS1A	---	---	80mA
R5-MS1A	---	---	80mA

R5 SERIES	R5T SERIES	MAX. CURRENT
R5-DA4	R5T-DA4	50mA
R5-DA16	---	80mA
R5-DC4	R5T-DC4	90mA
R5-DC16	---	80mA
R5-NC1	---	100mA
R5-NC2	---	110mA
R5-ND1	---	40mA
R5-ND2	---	40mA
R5-NE1	---	75mA
R5-NM1	---	50mA
R5-NP1	---	100mA
R5-NP2	---	100mA
R5-NF1	---	100mA



BASIC CONFIGURATIONS

■ R5-BS04, -BS08, -BS16

• Single Communication Mode (one network module)

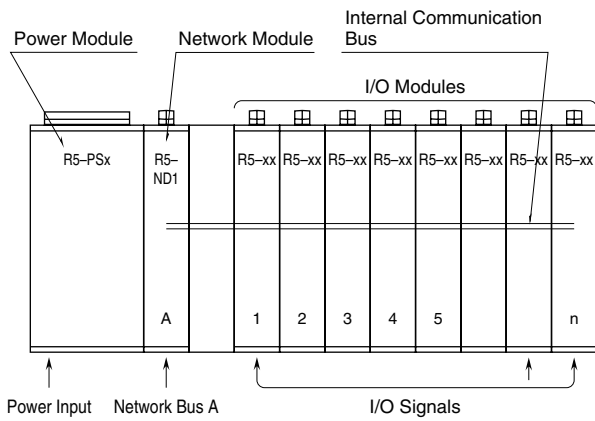

• Dual Communication Mode (two network modules)

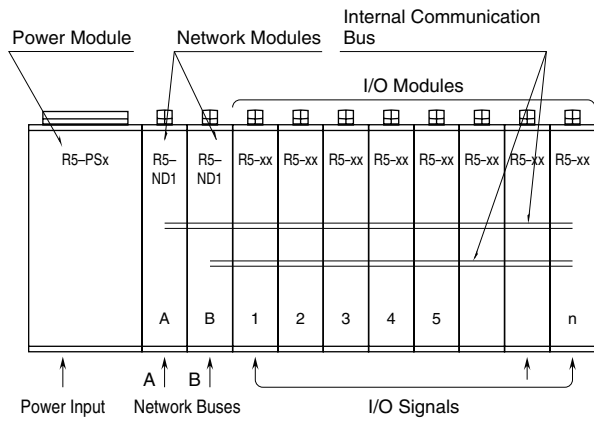

• Dual Redundant Power Supply

An extender base is available for an additional power supply module for dual redundancy.

■ R5-BS05, -BS09

• Single Communication Mode (one network module)

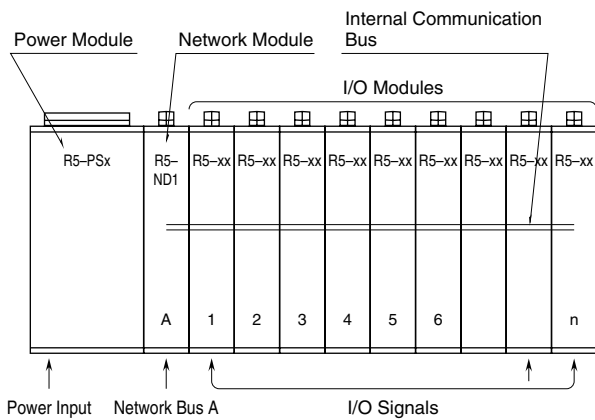

EXTERNAL DIMENSIONS unit: mm (inch)

■ 4 OR 5 I/O MODULE TYPE

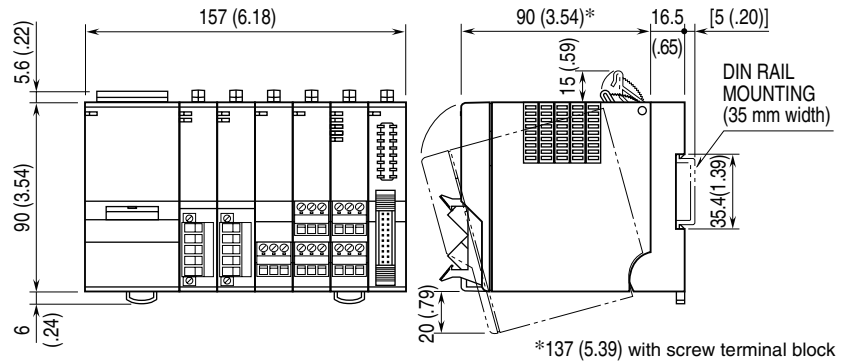

■ 8 OR 9 I/O MODULE TYPE

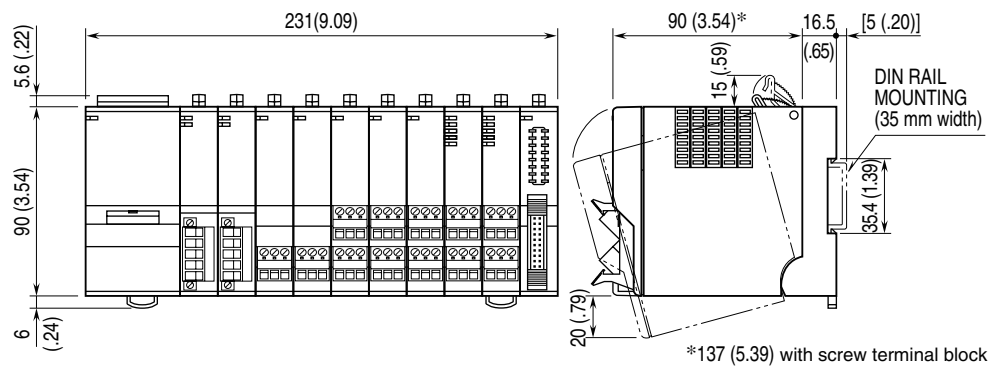

■ 16 I/O MODULE TYPE

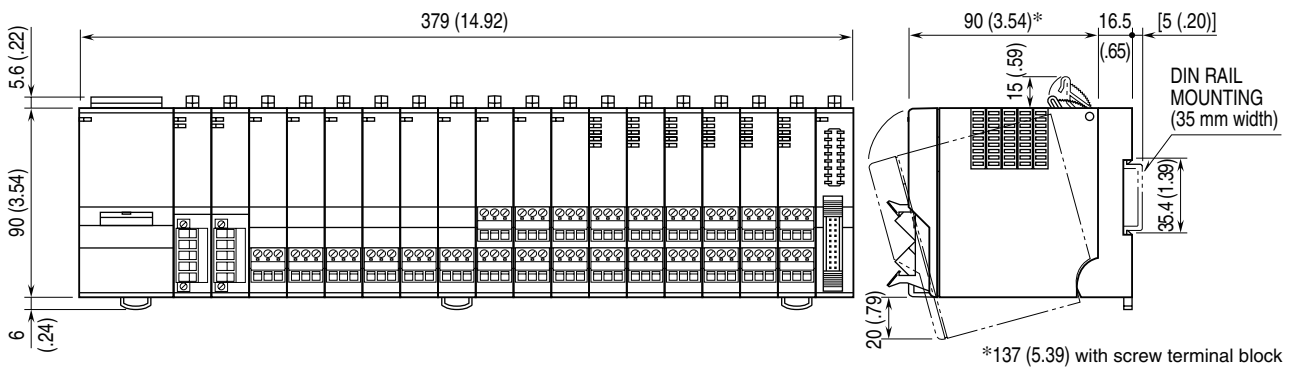

MOUNTING REQUIREMENTS unit: mm (inch)

■ MOUNTING DIRECTION

The unit must be mounted on a vertical panel. Mounting in any other angle will cause internal temperature to rise, may shorten the product's life expectation or deteriorate its performance.

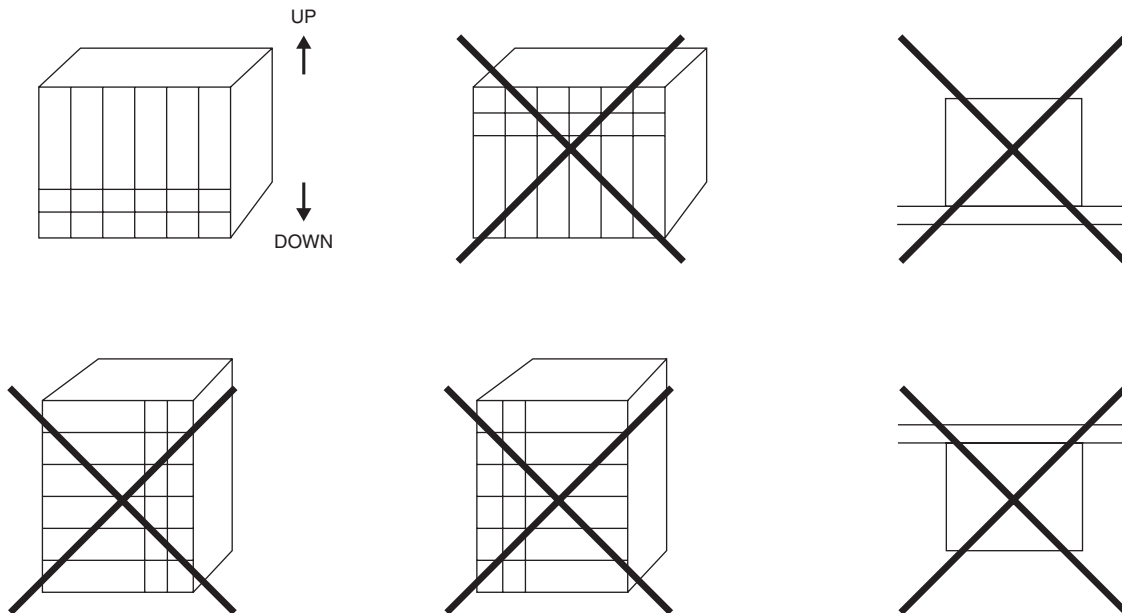

■ VENTILATION & MAINTENANCE SPACE

Maintain sufficient ventilation space. Do not mount the unit directly above devices which radiate great heat such as heaters, transformers or resistors.

Maintenance space is also required above and below the unit.

■ 4 OR 5 I/O MODULE TYPE

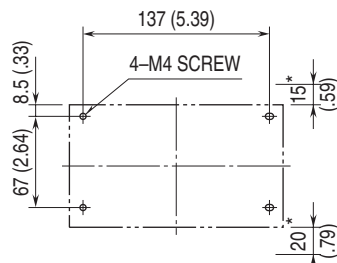

*Working space required for mounting/unmounting the modules.

■ 8 OR 9 I/O MODULE TYPE

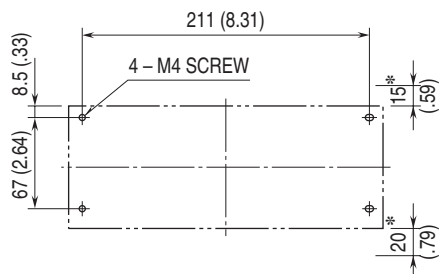

*Working space required for mounting/unmounting the modules.

■ 16 I/O MODULE TYPE

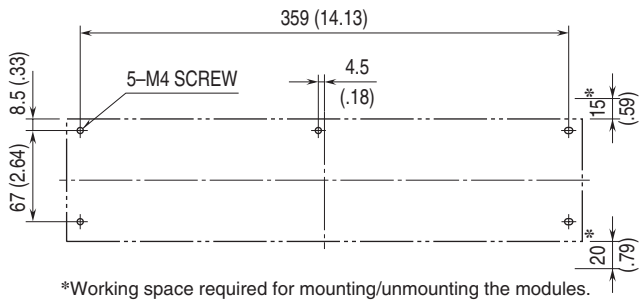

*Working space required for mounting/unmounting the modules.

SCHEMATIC CIRCUITRY & CONNECTION DIAGRAM

■ R5-BS04, -BS08, -BS16

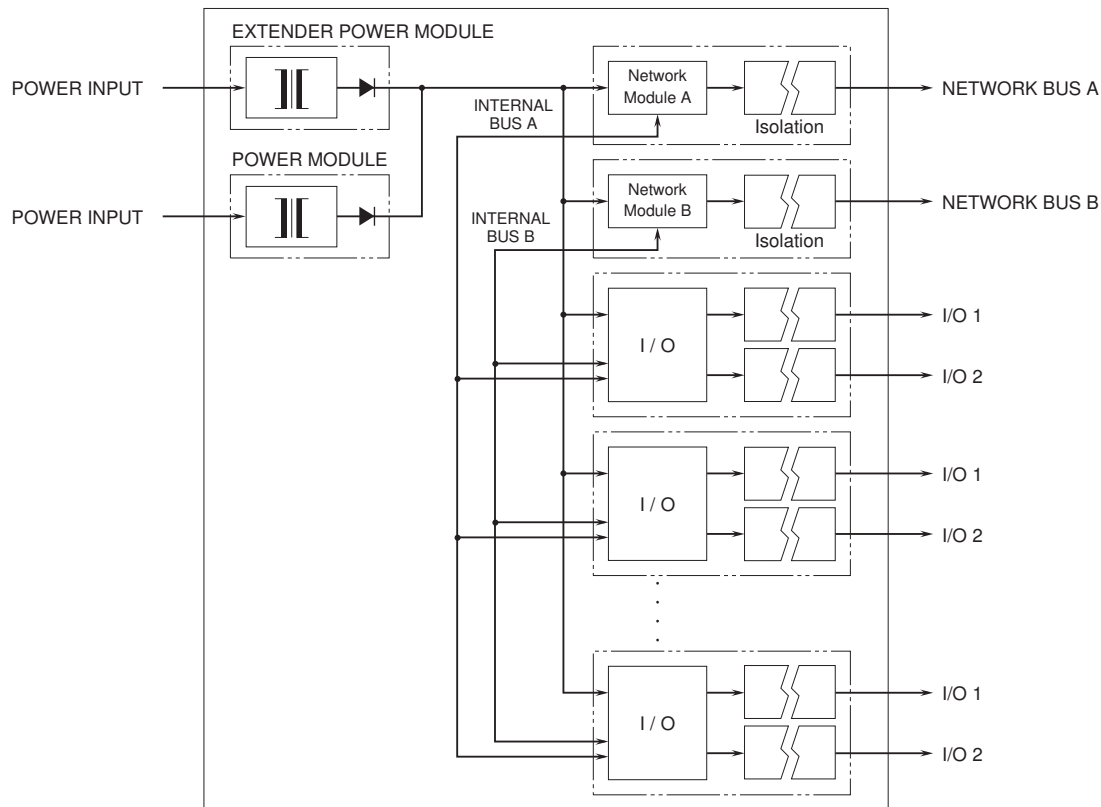

■ R5-BS05, -BS09

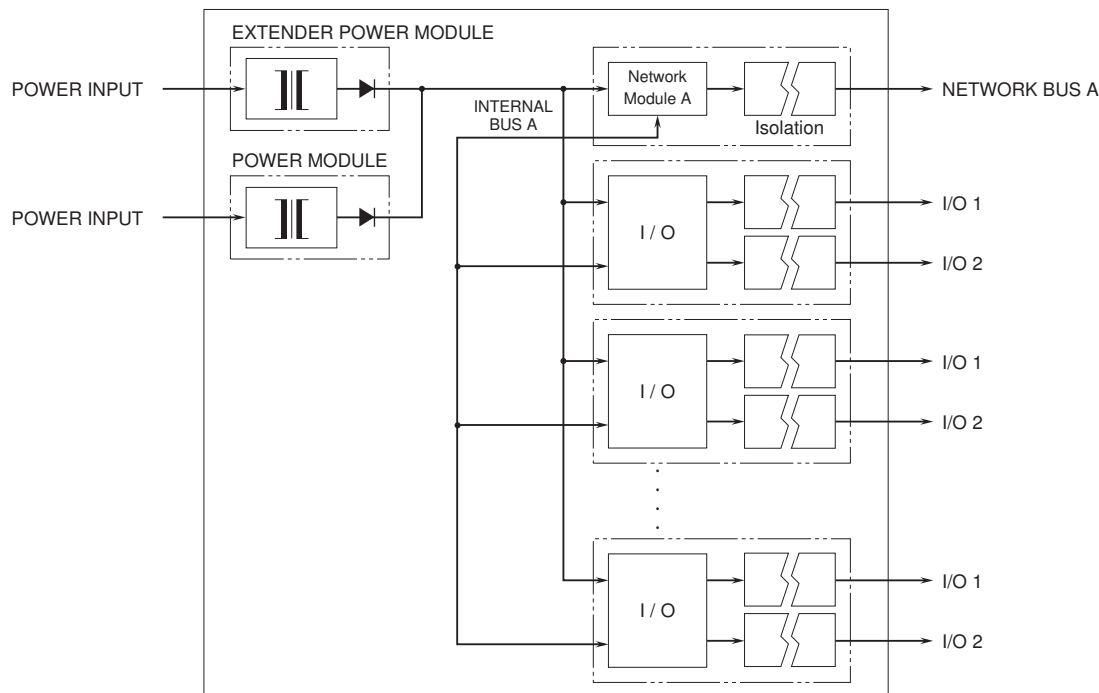

CONFORMITY WITH CE MARKING

■ CE MARKING

CE marking requires to integrate safety regulations existed in each country in EU territory and to secure smooth distribution of products of which safety is guaranteed. It is mandatory by law that products distributed and sold in EU territory to have CE mark which shows that the product conforms with the requirements of EC Directive. Each EC Directive describes the scope of apparatuses to which that EC Directive is applied. This product must conform with EMC Directive.

Each Directive states only basic requirements. In order to mark the CE on an assembled machinery equipment, its manufacturer needs to check the overall conformity with Directives applicable to it.

■ WARNINGS AND CAUTIONS WHEN INSTALLING

This product needs to be installed in a control panel. This is effective not only to ensure general safety but also to contain noise emissions by this product inside the control panel. We conduct a series of testing to see that the product conforms to EMC Directive while it is installed in the control panel.

Warning and cautions when installing are stated below.

- Use control panels with an internal panel plate, both made of metal, when installing.
- Make sure to adequately ground the control panel and the internal panel plate with a thick cable to maintain low impedance at high frequency.
- Use shielded cables for the signals taken out of the control panel.
- Choose a thick and short cable to ground the FG terminal of the Power Supply Module(s) and the Network Module(s) to the internal panel plate of the control panel.

Note: If electromagnetic radiation disturbance increases by grounding the FG terminal, remove the grounding.

- When painting the internal plate of the control panel, apply masking to expose metal surface to secure conductivity at the sections where the following parts are attached:
 - Bolts attaching the internal panel to the control panel
 - Ground for the FG of the Power Supply Module(s) and the Network Module(s)
 - Earth clamp on the shielded cable
- Noise emissions inside the control panel might leak through its openings. Design them as small as possible. Recommended diameter is 10 cm or less.



Supplement:

Additional measures may be taken depending upon actual installation sites. These points of cautions are illustrated below.

- Prevent noise leakage by wrapping cables using shield covers, shield tubes and flexible conduits etc. if noise leaks through the cable outlet.
- Use an electromagnetic shield gasket and block up the gap between the control panel cabinet and its cover, if noise leaks through it.
- Connecting the internal panel plate and the cover of the control panel to the main cabinet using an earth strap may be effective to strengthen the grounding.
- Electromagnetically shielded control panel cabinet is effective for shielding.

• Points of cautions applicable when installing the R5 Series

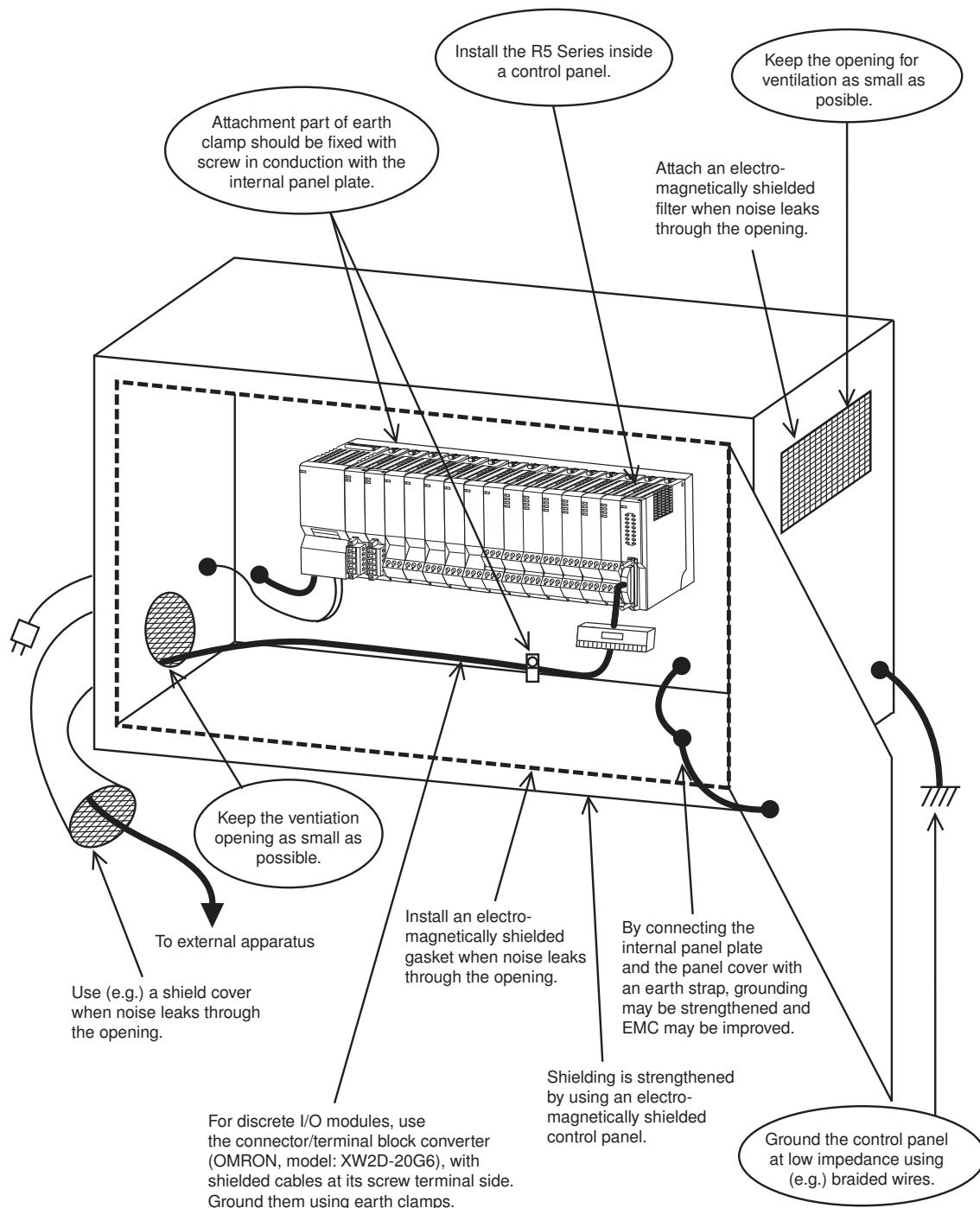

■ WARNINGS AND CAUTIONS WHEN LAYING CABLES

Signal cables connected to the R5 Series contain high-frequency components. Since these cables have the same effect as an antenna, they emit these high-frequency components to the external space as noise or overlap noise from the external space on themselves.

Cables with shielding should be used for the signal line due to the above reason.

EMC conformance test is conducted in the condition that shielded cables and earth clamps are used with the R5 Series.

Warning and cautions when laying cables are stated below. These points of cautions are illustrated in the next page.

- Use shielded cables for those signal cables installed out of the control panel and for thermocouple and RTD extension wires.
- All the network cables connected to R5 series should be shielded.
- Use STP cables, called either S/FTP or SF/UTP in ISO/IEC 11801 : 2002, for R5-NEx.
- Use exclusively designed cables for the CC-Link, DeviceNet or PROFIBUS-DP.
- Expose the shield at a part of the cable cover, clip it with an earth clamp, and ground it to the internal panel of the control panel. A drain wire connected to the panel in a pig-tail form cannot maintain low impedance against high-frequency noise, thus grounding (noise shielding) in this form will not be effective.

For DeviceNet, grounding should be taken at single point in the network.

Supplement:

Additional measures may be taken depending upon actual installation sites. These points of cautions are illustrated in the next page.

- Keep cables as short as possible. It prevents noise emissions from the cables and noise overlapping to the cables.
- Attach a ferrite core to reduce noise impact to the signal cables susceptible to the noise. Ferrite core can be attached close to the cable outlet of the control panel or close to the I/O terminal or connector, whichever is more effective. Also, the impact might be reduced by winding the cable around the ferrite core for extra turns or attaching multiple ferrite cores.
- Keep cables which are easily affected by noise away from those which can be a noise source.

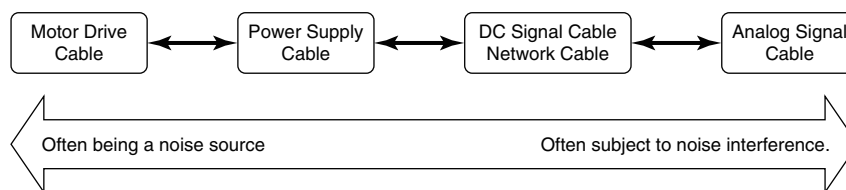

In the following are examples of effective ways to lay cables separately:

- Keeping physical distance (farther than 20 cm from motor drive cables, farther than 10 cm for other groups).
- Dividing off by a grounded metal plate
- Grouping into separate grounded metal pipes or cable shields.

Wires on each side of a filter should not be too close to each other. Noise could ride onto the other side of cable.

Extra attention needs to be paid at the following parts.

- Noise filter that is enclosed in power cables.
- Ferrite core that is attached to signal cables.
- Noise limiting circuit (surge quenching circuit, transient absorber circuit, etc.) that is enclosed in signal cables.



• Points of cautions applicable when wiring the R5 Series

