

Remote I/O R3 Series

AC POWER INPUT MODULE

(4 input circuits, clamp-on current sensor type CLSA use)

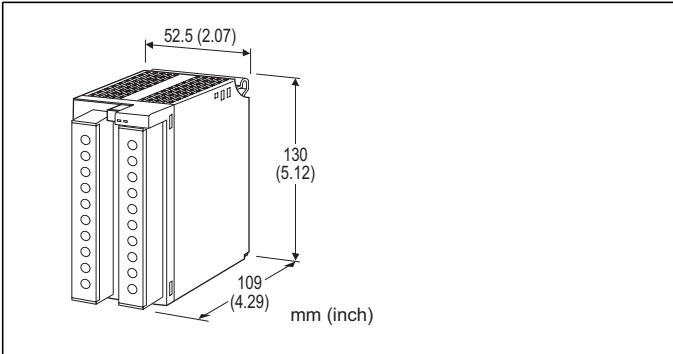

MODEL: R3-WT4A[1][2][3][4]

ORDERING INFORMATION

- Code number: R3-WT4A[1][2][3][4]
Specify a code from below for each [1] through [4].
(e.g. R3-WT4A11W/Q)
- Specify the specification for option code /Q
(e.g. /C01)

NO. OF CHANNELS

4A: 4 channels, Sensor type CLSA

[1] CONFIGURATION

- 1: 3-phase / 3-wire
- 2: Single-phase / 2-wire
- 3: Single-phase / 3-wire

[2] INPUT (unbalanced load)

- 1: 110 V AC / 80 A
- 2: 110 V AC / 120 A
- 5: 220 V AC / 80 A
- 6: 220 V AC / 120 A
- A: 200 V AC / 80 A (single-phase/3-wire)
- B: 200 V AC / 120 A (single-phase/3-wire)

[3] COMMUNICATION MODE

- S: Single
- W: Dual

[4] OPTIONS

- blank: none
- /Q: With options (specify the specification)

SPECIFICATIONS OF OPTION: Q

COATING (For the detail, refer to M-System's web site.)

- /C01: Silicone coating
- /C02: Polyurethane coating
- /C03: Rubber coating

RELATED PRODUCTS

- PC configurator software (model: R3CON)
The R3CON is used to set up the software setting of this module. Downloadable at M-System's web site.
 - Clamp-on current sensor (model: CLSA-08)
 - Clamp-on current sensor (model: CLSA-12)
 - Special cable (model: CLSA-08C)
- Note: The clamp-on current sensor, not included in the product package of the R3 module, must be ordered separately. Refer to the data sheet for the sensor for more information such as applicable wire diameter.

GENERAL SPECIFICATIONS

Connection

- Internal bus:** Via the Installation Base (model: R3-BSx)
- Input:** M3.5 screw terminals (torque 0.8 N·m)
- Internal power:** Via the Installation Base (model: R3-BSx)
- Screw terminal:** Nickel-plated steel
- Isolation:** Sensor core to sensor output or current input or internal bus or internal power to voltage input
- Computation:** Time division multiplication
- DIP switch settings:**

- Measuring variables
- Computation methods
- Count Reset (Disable/Enable)
- Others

Refer to the instruction manual for details.

- RUN indicator:** Bi-color (red/green) LED;
Red when the bus A operates normally;
Green when the bus B operates normally;
Amber when both buses operate normally.

- ERR indicator:** Bi-color (red/green) LED;
Red with the input abnormality;
Green in normal operating conditions.

Power ON timer: Starts conversion in 10 seconds after the power is turned on.

Low-end cutout: Converted data forced to 0 % for 2 % or less input. (Selectable by using R3CON)

INPUT SPECIFICATIONS

Frequency: 50 or 60 Hz

- **Voltage Input**
- Operational range:** 0 - 120 % of rating
- Overload capacity:** 150 % of rating for 10 sec., 120 % continuous



•Current Input

Range

CLSA-08: 0 - 80 A AC

CLSA-12: 0 - 120 A AC

Operational range: 0 - 115 % of rating

■ Active Power Input Range

Choose VT ratio so that the calibration range calculated by the following equation is within the usable range in the next table.

$$\text{Calibration Range [W]} = \text{Measuring Wattage [W]} \div [(\text{VT Ratio}) \times (\text{Current Rating})]$$

•Single-phase/2-wire

INPUT	USABLE RANGE	VT BURDEN (VA)
110V / 80A	±8800W	0.2/phase
110V / 120A	±13200W	
220V / 80A	±17600W	0.4/phase
220V / 120A	±26400W	

•Single-phase/3-wire

INPUT	USABLE RANGE	VT BURDEN (VA)
200V / 80A	±16000W	0.2/phase
200V / 120A	±24000W	

•3-phase/3-wire

INPUT	USABLE RANGE	VT BURDEN (VA)
110V / 80A	±15240W	0.2/phase
110V / 120A	±22860W	
220V / 80A	±30480W	0.4/phase
220V / 120A	±45730W	

INSTALLATION

Operating temperature: -10 to +55°C (14 to 131°F)

Operating humidity: 30 to 90 %RH (non-condensing)

Atmosphere: No corrosive gas or heavy dust

Mounting: Installation Base (model: R3-BSx)

Weight: 350 g (0.77 lb)

PERFORMANCE

Accuracy

(at 23°C ±10°C or 73.4°F ±18°F, 45 - 65 Hz)

Active power: ±2 %

Active energy: ±2 %

Magnetic field (ext. origin) effect: ± 0.5 % (400 A/m)

Conversion rate: 100 msec.

Conversion data: 16 bits / 32 bits

Data allocation: 4, 8 or 16 selectable

Current consumption: 150 mA

Response time: ≤ 2 sec. (0 - 100 % ±1 %)

Insulation resistance: ≥ 100 MΩ with 500 V DC (voltage input to current input or internal power)

≥ 100 MΩ with 500 V DC (sensor core to sensor output)

Dielectric strength: 2000 V AC @ 1 minute (voltage input to current input or internal bus or internal power)



EXTERNAL VIEW

■ FRONT VIEW

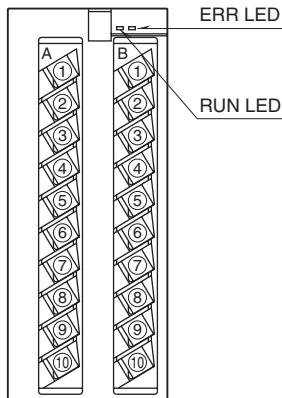

■ SIDE VIEW

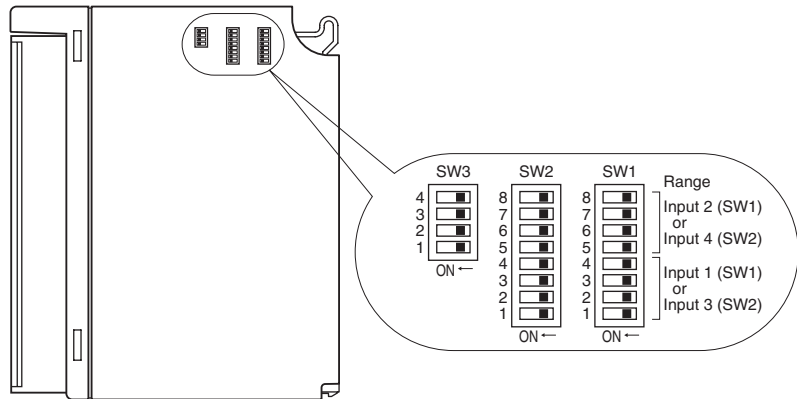

TRANSMISSION DATA DESCRIPTIONS

ADDRESS	VARIABLE A	active power 16 bits	active power 16 bits	incoming energy 16 bits	incoming energy 32 bits
	VARIABLE B	incoming energy 16 bits	incoming energy 32 bits	outgoing energy 16 bits	outgoing energy 32 bits
	VARIABLE C	outgoing energy 16 bits	----	----	----
n		active power ch.1	active power ch.1	incoming energy ch.1	incoming energy ch.1, lower digits
n + 1		active power ch.2	active power ch.2	incoming energy ch.2	incoming energy ch.1, upper digits
n + 2		active power ch.3	active power ch.3	incoming energy ch.3	incoming energy ch.2, lower digits
n + 3		active power ch.4	active power ch.4	incoming energy ch.4	incoming energy ch.2, upper digits
n + 4		incoming energy ch.1	incoming energy ch.1, lower digits	outgoing energy ch.1	incoming energy ch.3, lower digits
n + 5		incoming energy ch.2	incoming energy ch.1, upper digits	outgoing energy ch.2	incoming energy ch.3, upper digits
n + 6		incoming energy ch.3	incoming energy ch.2, lower digits	outgoing energy ch.3	incoming energy ch.4, lower digits
n + 7		incoming energy ch.4	incoming energy ch.2, upper digits	outgoing energy ch.4	incoming energy ch.4, upper digits
n + 8		outgoing energy ch.1	incoming energy ch.3, lower digits	0	outgoing energy ch.1, lower digits
n + 9		outgoing energy ch.2	incoming energy ch.3, upper digits	0	outgoing energy ch.1, upper digits
n + 10		outgoing energy ch.3	incoming energy ch.4, lower digits	0	outgoing energy ch.2, lower digits
n + 11		outgoing energy ch.4	incoming energy ch.4, upper digits	0	outgoing energy ch.2, upper digits
n + 12		0	0	0	outgoing energy ch.3, lower digits
n + 13		0	0	0	outgoing energy ch.3, upper digits
n + 14		0	0	0	outgoing energy ch.4, lower digits
n + 15		0	0	0	outgoing energy ch.4, upper digits
SW3-3 / SW3-4 setting		OFF / OFF	ON / OFF	OFF / ON	ON / ON
R3CON type ID		WT4A***0	WT4A***1	WT4A***2	WT4A***3
Network Module Data Allocation Mode*1		4, 8, 16	4, 8, 16	4, 8	4, 8, 16

n = I/O address on the installation base

Factory setting = 1 kWh per bit.

Data address depends upon the data allocation mode as indicated below:

4 (n thr. n+3)

8 (n thr. n+7)

16 (n thr. n+15)

*1. Fixed at 16 for the R3-NPx.



幸託有限公司
XIN TOP CORPORATION

TEL : (02)2598-1199

FAX : (02)2596-2331

E-mail : info@xintop.com

Website : www.xintop.com

I/O DATA DESCRIPTIONS

■ **16-BIT DATA**

16-bit binary data. Minus values are represented in 2's complements.



■ **32-BIT DATA**

32-bit binary data. Minus values are represented in 2's complements.

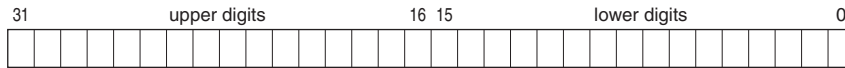

EXTERNAL DIMENSIONS & TERMINAL ASSIGNMENTS unit: mm (inch)

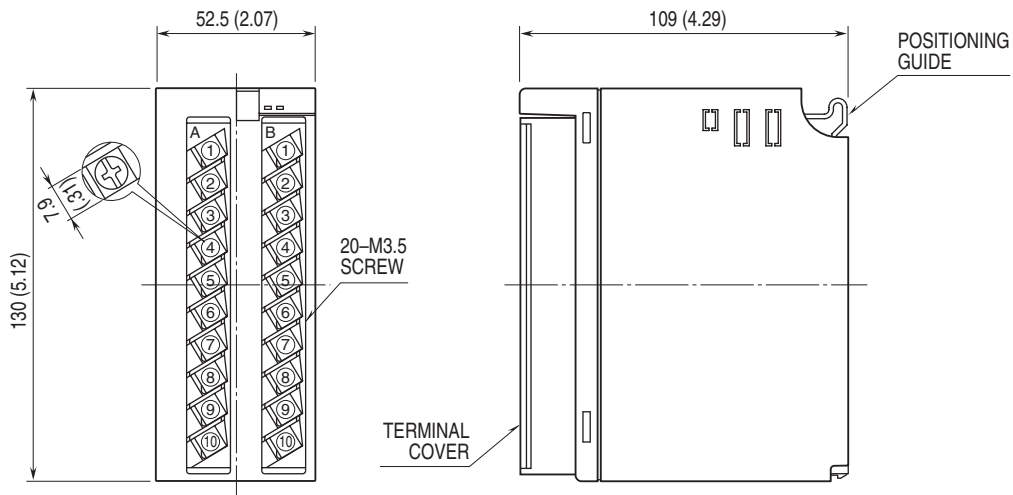

SCHEMATIC CIRCUITRY & CONNECTION DIAGRAM

■ 3-PHASE/3-WIRE

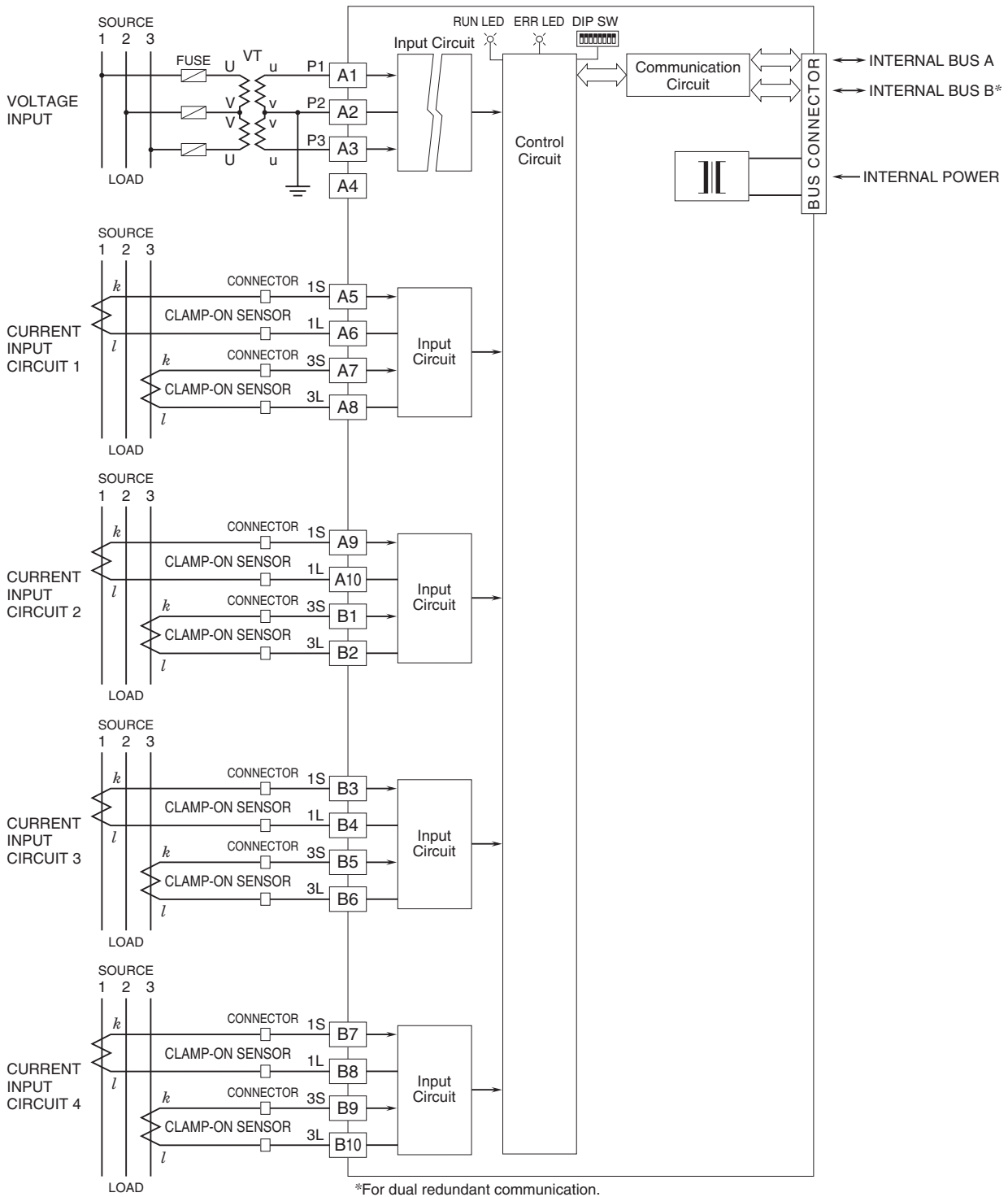

■ SINGLE-PHASE/2-WIRE

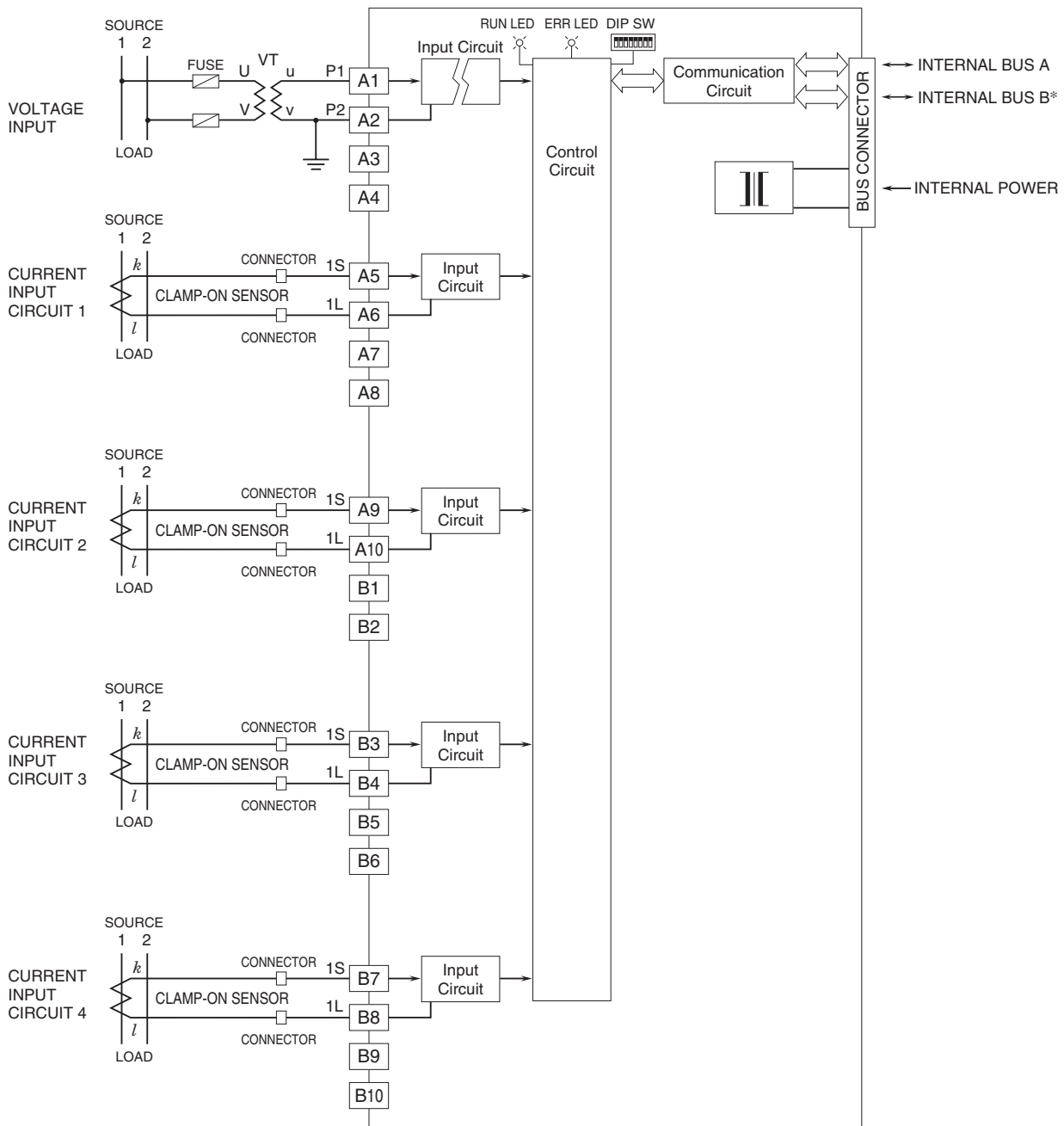

*For dual redundant communication.



■ SINGLE-PHASE/3-WIRE

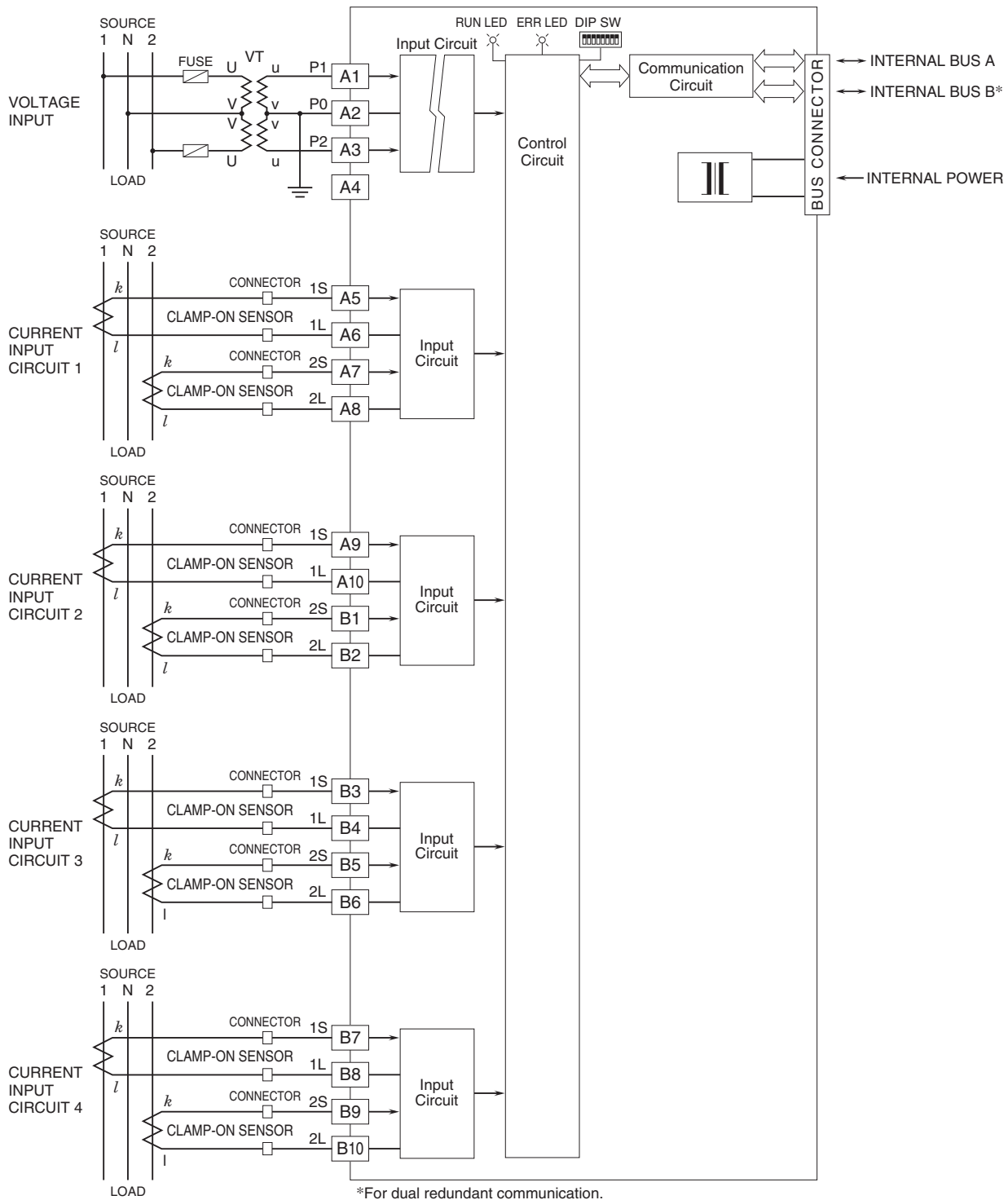

Specifications are subject to change without notice.

