

Remote I/O R3 Series

MULTI POWER INPUT MODULE

(clamp-on current sensor type CLSA use)

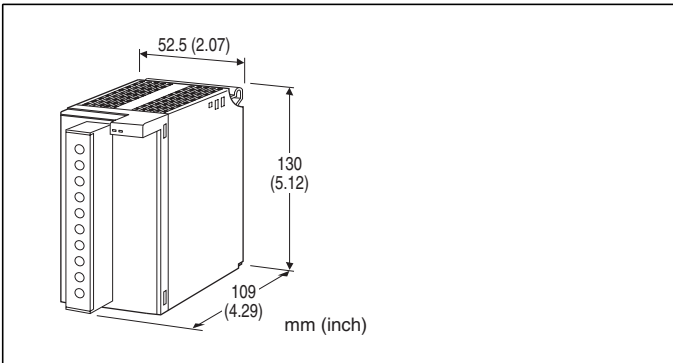

MODEL: R3-WT1A[1][2][3][4]

ORDERING INFORMATION

- Code number: R3-WT1A[1][2][3][4]
Specify a code from below for each [1] through [4].
(e.g. R3-WT1A11W/Q)
- Specify the specification for option code /Q
(e.g. /C01)

NO. OF SYSTEMS

1A: 1, Sensor type CLSA

[1] CONFIGURATION

- 1: 3-phase / 3-wire
- 2: Single-phase / 2-wire
- 3: Single-phase / 3-wire

[2] INPUT (unbalanced load)

- 1: 110 V AC / 80 A
 - 2: 110 V AC / 120 A
 - 5: 220 V AC / 80 A
 - 6: 220 V AC / 120 A
- A: 100 V / 200 V AC / 80 A (single-phase/3-wire)
B: 100 V / 200 V AC / 120 A (single-phase/3-wire)

[3] COMMUNICATION MODE

- S: Single
W: Dual

[4] OPTIONS

- blank: none
/Q: With options (specify the specification)

SPECIFICATIONS OF OPTION: Q

COATING (For the detail, refer to M-System's web site.)

- /C01: Silicone coating
- /C02: Polyurethane coating
- /C03: Rubber coating

RELATED PRODUCTS

- PC configurator software (model: R3CON)
The R3CON is used to set up the software setting of this module. Downloadable at M-System's web site.
 - Clamp-on current sensor (model: CLSA-08)
 - Clamp-on current sensor (model: CLSA-12)
 - Special cable (model: CLSA-08C)
- Note: The clamp-on current sensor, not included in the product package of the R3 module, must be ordered separately. Refer to the data sheet for the sensor for more information such as applicable wire diameter.

GENERAL SPECIFICATIONS

Connection

- Internal bus:** Via the Installation Base (model: R3-BSx)
- Input:** M3.5 screw terminals (torque 0.8 N·m)
- Internal power:** Via the Installation Base (model: R3-BSx)
- Screw terminal:** Nickel-plated steel
- Isolation:** Sensor core to sensor output or current input or internal bus or internal power to voltage input
- DIP switch settings:**
 - Computation methods
 - Count Reset (Disable/Enable)
 - Others

Refer to the instruction manual for details.

- RUN indicator:** Bi-color (red/green) LED;
Red when the bus A operates normally;
Green when the bus B operates normally;
Amber when both buses operate normally.

- ERR indicator:** Bi-color (red/green) LED;
Red with the input abnormality;
Green in normal operating conditions.

Power ON timer: Starts conversion in 10 seconds after the power is turned on.

Low-end cutout: Converted data forced to 0 % for 2 % or less input. (Selectable by using R3CON)

Computation

- Active power, reactive power:** Time division multiplication
- Power factor:** Calculated with active power (P) and reactive power (Q)

$$\frac{P}{\sqrt{P^2 + Q^2}}$$

Frequency: One-shot



INPUT SPECIFICATIONS

Frequency: 50 or 60 Hz

•Voltage Input

Operational range: 0 - 120 % of rating

Overload capacity: 150 % of rating for 10 sec., 120 % continuous

•Current Input

Range

CLSA-08: 0 - 80 A AC

CLSA-12: 0 - 120 A AC

Operational range: 0 - 115 % of rating

■ Power Factor Input Range:

-1 - lag 0 - 1 - lead 0 - -1

Data range: -1000 - 0 - 1000 - 0 - -1000 with SW2-1 set to OFF

A device which employs different measuring methods may show different outputs from that of M-System's.

■ Frequency Input Range: 45 - 65 Hz

Data range: 4500 - 6500

■ ACTIVE / REACTIVE POWER INPUT RANGE

•Single-phase/2-wire

INPUT	USABLE RANGE	VT BURDEN (VA)
110V / 80A	±8800W	0.2/phase
110V / 120A	±13200W	
220V / 80A	±17600W	0.4/phase
220V / 120A	±26400W	

•Single-phase/3-wire

INPUT	USABLE RANGE	VT BURDEN (VA)
200V / 80A	±16000W	0.2/phase
200V / 120A	±24000W	

•3-phase/3-wire

INPUT	USABLE RANGE	VT BURDEN (VA)
110V / 80A	±15240W / ^{lead} 15240 var / _{lag}	0.2/phase
110V / 120A	±22860W / ^{lead} 22860 var / _{lag}	
220V / 80A	±30480W / ^{lead} 30480 var / _{lag}	0.4/phase
220V / 120A	±45730W / ^{lead} 45730 var / _{lag}	

Reactive power data in Lead: Positive, Lag: Negative
Note: Reactive power is invalid in single-phase systems.

Choose VT ratio so that the calibration range calculated by the following equation is within the usable range in the above table.

$$\text{Calibration Range [W]} = \frac{\text{Measuring Wattage [W]}}{(\text{VT Ratio}) \times (\text{Current Rating})}$$

INSTALLATION

Operating temperature: -10 to +55°C (14 to 131°F)

Operating humidity: 30 to 90 %RH (non-condensing)

Atmosphere: No corrosive gas or heavy dust

Mounting: Installation Base (model: R3-BSx)

Weight: 300 g (0.66 lb)

PERFORMANCE

Accuracy

(at 23°C ±10°C or 73.4°F ±18°F, 45 - 65 Hz) (Except the sensor's accuracy.)

Active / reactive power: ±2 % (Add sensor's accuracy for overall performance)

Power factor: ±4 % (Add sensor's accuracy for overall performance)

Frequency: ±1 %

Active / reactive energy: ±2 % (Add sensor's accuracy for overall performance)

Magnetic field (ext. origin) effect: ± 0.5 % (400 A/m)

Conversion rate: 100 msec.

Conversion data: 16 bits / 32 bits

Data allocation: 4, 8 or 16 selectable

Current consumption: 150 mA

Response time: ≤ 2 sec. (0 - 100 % ±1 %)

Insulation resistance: ≥ 100 MΩ with 500 V DC

Dielectric strength: 2000 V AC @ 1 minute (voltage input to current input or internal bus or internal power)

2000 V AC @ 1 minute (power input to FG; isolated on the power supply module)



EXTERNAL VIEW

FRONT VIEW

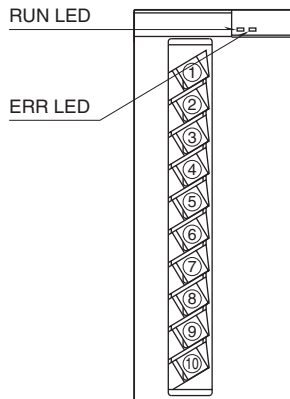

SIDE VIEW

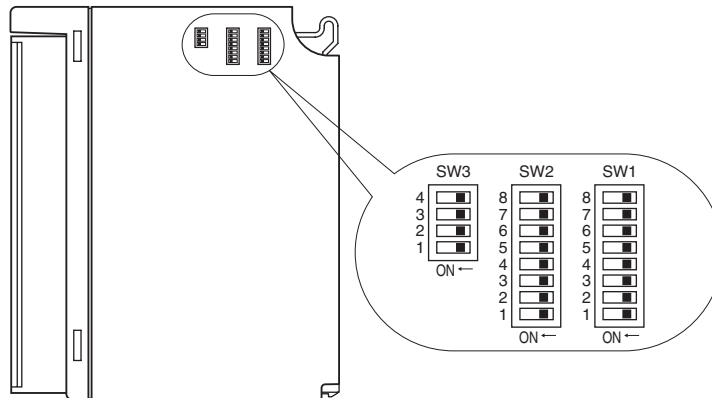

TRANSMISSION DATA DESCRIPTIONS

ADDRESS	CONTENTS
n	Active power *2
n + 1	Reactive power *2
n + 2	Power factor *2
n + 3	Frequency *2
n + 4	Incoming active energy (lower bits)]*3
n + 5	Incoming active energy (upper bits)]
n + 6	Outgoing active energy (lower bits)]*3
n + 7	Outgoing active energy (upper bits)]
n + 8	LAG reactive energy (lower bits)]*3
n + 9	LAG reactive energy (upper bits)]
n + 10	LEAD reactive energy (lower bits)]*3
n + 11	LEAD reactive energy (upper bits)]
n + 12	0
n + 13	0
n + 14	0
n + 15	0
R3CON type ID	WT1A***
Network module data allocation mode example *1	4, 8, 16

n = I/O address on the installation base
 Factory setting = 1 kWh and 1 kvarh per bit.
 Data address depends upon the data allocation mode as indicated below:

- 4 (n thr. n+3)
- 8 (n thr. n+7)
- 16 (n thr. n+15)

- *1. Fixed at 16 for the R3-NP_x.
- *2. 16-bit data
- *3. 32-bit data

I/O DATA DESCRIPTIONS

16-BIT DATA

16-bit binary data. Minus values are represented in 2's complements.



32-BIT DATA

32-bit binary data. Minus values are represented in 2's complements.

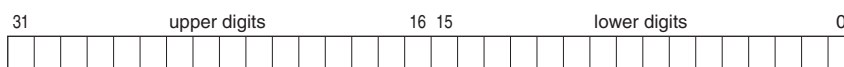

EXTERNAL DIMENSIONS & TERMINAL ASSIGNMENTS unit: mm (inch)

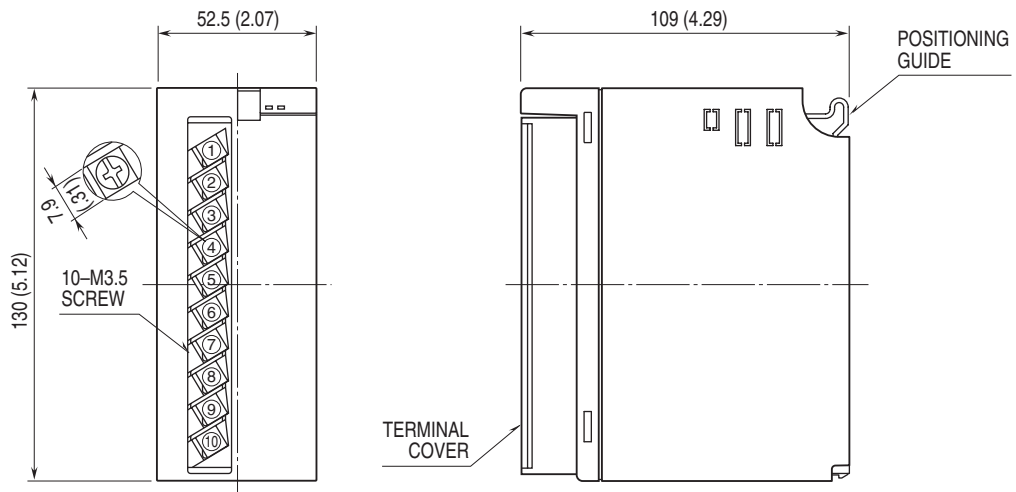

SCHEMATIC CIRCUITRY & CONNECTION DIAGRAM

■ 3-PHASE/3-WIRE

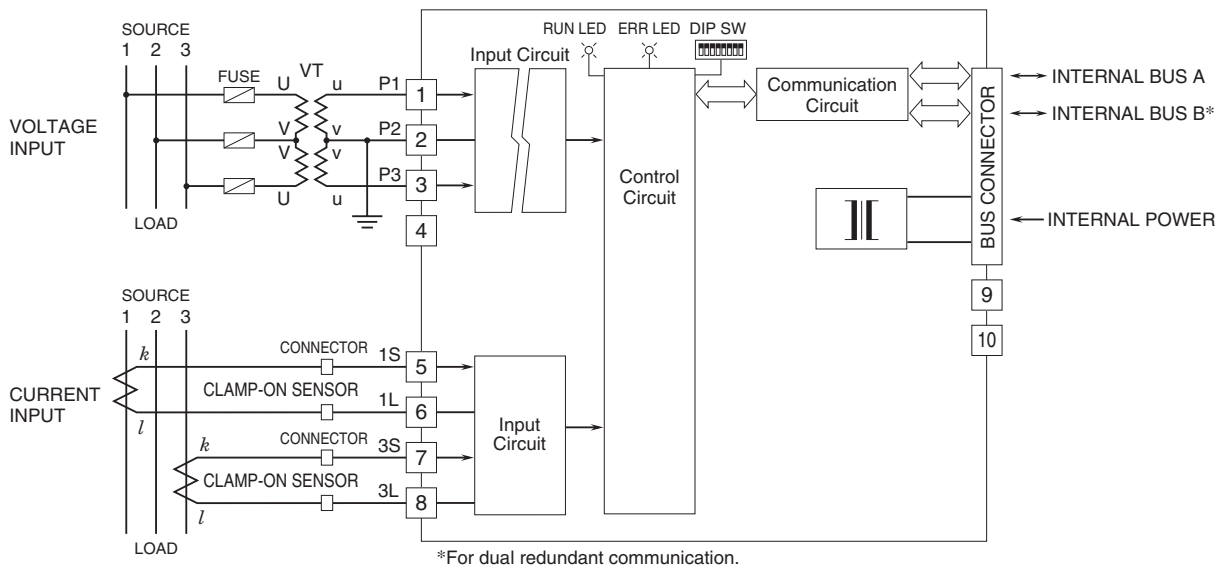

■ SINGLE-PHASE/2-WIRE

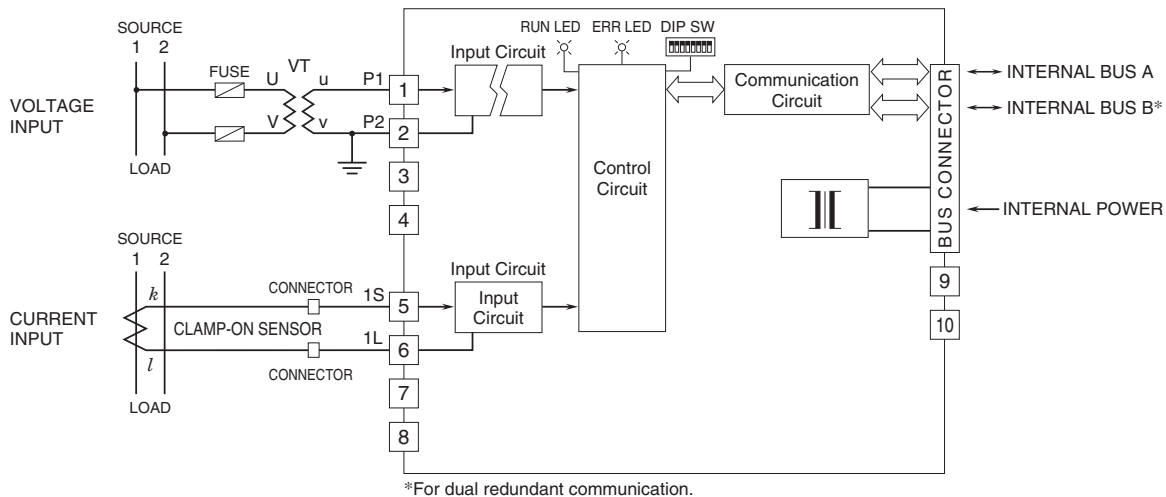

■ SINGLE-PHASE/3-WIRE

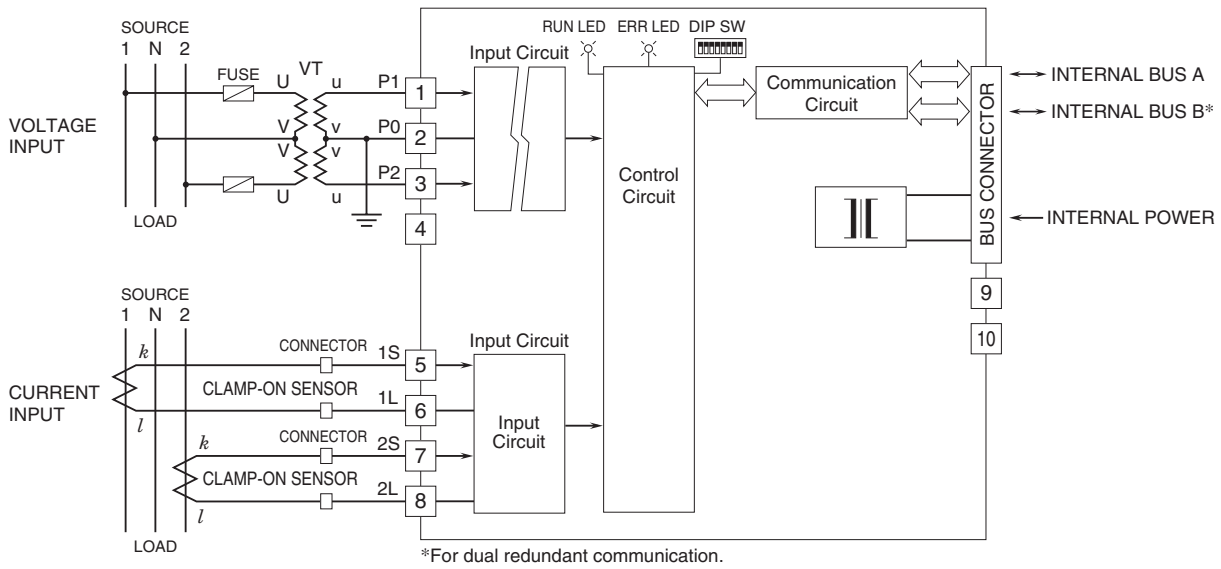

Specifications are subject to change without notice.

