

Remote I/O R3 Series

MULTI POWER INPUT MODULE

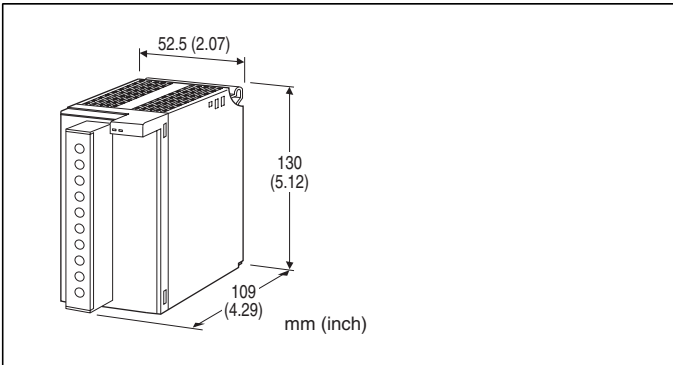

MODEL: R3-WT1[1][2]1[3][4]

ORDERING INFORMATION

- Code number: R3-WT1[1][2]1[3][4]
Specify a code from below for each [1] through [4].
(e.g. R3-WT1111W/Q)
- Specify the specification for option code /Q
(e.g. /C01)

NO. OF SYSTEMS

1: 1

[1] CONFIGURATION

- 1: 3-phase / 3-wire
- 2: Single-phase / 2-wire
- 3: Single-phase / 3-wire

[2] INPUT (unbalanced load)

- 1: 110 V / 5 A AC
- 2: 110 V / 1 A AC
- 3: 220 V / 1 A AC
- 4: 220 V / 5 A AC
- A: 100 V / 200 V / 1 A AC (single-phase / 3- wire)
- B: 100 V / 200 V / 5 A AC (single-phase / 3- wire)

MEASURING VARIABLE

1: Active power / reactive power / power factor / frequency / active energy / reactive energy

[3] COMMUNICATION MODE

- S: Single
- W: Dual

[4] OPTIONS

- blank: none
- /Q: With options (specify the specification)

SPECIFICATIONS OF OPTION: Q

COATING (For the detail, refer to M-System's web site.)

- /C01: Silicone coating
- /C02: Polyurethane coating
- /C03: Rubber coating

RELATED PRODUCTS

- PC configurator software (model: R3CON)
The R3CON is used to set up the software setting of this module. Downloadable at M-System's web site.

GENERAL SPECIFICATIONS

Connection

- Internal bus:** Via the Installation Base (model: R3-BSx)
- Input:** M3.5 screw terminals (torque 0.8 N·m)
- Internal power:** Via the Installation Base (model: R3-BSx)
- Screw terminal:** Nickel-plated steel
- Isolation:** Voltage input to current input to internal bus or internal power

DIP switch settings:

- Computation methods
- Count Reset (Disable/Enable)
- Others

Refer to the instruction manual for details.

- RUN indicator:** Bi-color (red/green) LED;
Red when the bus A operates normally;
Green when the bus B operates normally;
Amber when both buses operate normally.

- ERR indicator:** Bi-color (red/green) LED;
Red with the input abnormality;
Green in normal operating conditions.

Power ON timer: Starts conversion in 10 seconds after the power is turned on.

Low-end cutout: Converted data forced to 0 % for 2 % or less input. (Selectable by using R3CON)

Computation

Active power, reactive power: Time division multiplication

Power factor: Calculated with active power (P) and reactive power (Q)

$$\frac{P}{\sqrt{P^2 + Q^2}}$$

Frequency: One-shot



INPUT SPECIFICATIONS

Frequency: 50 or 60 Hz

•Voltage Input

Operational range: 0 - 120 % of rating

Overload capacity: 150 % of rating for 10 sec., 120 % continuous

•Current Input

Operational range: 0 - 120 % of rating

Overload capacity: 1000 % of rating for 3 sec., 200 % for 10 sec., 120 % continuous

■ Power Factor Input Range:

-1 - lag 0 - 1 - lead 0 - -1

Data range: -1000 - 0 - 1000 - 0 - -1000 with SW2-1 set to OFF

A device which employs different measuring methods may show different outputs from that of M-System's.

■ Frequency Input Range: 45 - 65 Hz

Data range: 4500 - 6500

■ACTIVE / REACTIVE POWER INPUT RANGE

•Single-phase/2-wire

INPUT	USABLE RANGE	BURDEN (VA)	
		VT	CT
110V / 1A	±100W	0.2	0.1
110V / 5A	±500W		0.5
220V / 1A	±200W	0.4	0.1
220V / 5A	±1000W		0.5

•Single-phase/3-wire

INPUT	USABLE RANGE	BURDEN (VA)	
		VT	CT
200V / 1A	±200W	0.2/phase	0.1/phase
200V / 5A	±1000W		0.5/phase

•3-phase/3-wire

INPUT	USABLE RANGE	BURDEN (VA)	
		VT	CT
110V / 1A	±200W / ^{lead} / _{lag} 200 var	0.2/phase	0.1/phase
110V / 5A	±1000W / ^{lead} / _{lag} 1000 var		0.5/phase
220V / 1A	±400W / ^{lead} / _{lag} 400 var	0.4/phase	0.1/phase
220V / 5A	±2000W / ^{lead} / _{lag} 2000 var		0.5/phase

Reactive power data in Lead: Positive, Lag: Negative
Reactive power is invalid in single-phase systems

Choose VT and CT ratios so that the calibration range calculated by the following equation is within the usable range in the above table.

$$\text{Calibration Range [W]} = \frac{\text{Measuring Wattage [W]}}{(\text{VT Ratio}) \times (\text{CT Ratio})}$$

INSTALLATION

Operating temperature: -10 to +55°C (14 to 131°F)

Operating humidity: 30 to 90 %RH (non-condensing)

Atmosphere: No corrosive gas or heavy dust

Mounting: Installation Base (model: R3-BSx)

Weight: 300 g (0.66 lb)

PERFORMANCE

Accuracy (at 23°C ±10°C or 73.4°F ±18°F, 45 - 65 Hz)

Active / reactive power: ±1 %

Power factor: ±2 %

Frequency: ±1 %

Active / reactive energy: ±2 %

Magnetic field (ext. origin) effect: ± 0.5 % (400 A/m)

Conversion rate: 100 msec.

Conversion data: 16 bits / 32 bits

Data allocation: 4, 8 or 16 selectable

Current consumption: 150 mA

Response time: ≤ 2 sec. (0 - 100 % ±1 %)

Insulation resistance: ≥ 100 MΩ with 500 V DC

Dielectric strength: 2000 V AC @ 1 minute (voltage input to current input to internal bus or internal power)

2000 V AC @ 1 minute (power input to FG; isolated on the power supply module)



EXTERNAL VIEW

FRONT VIEW

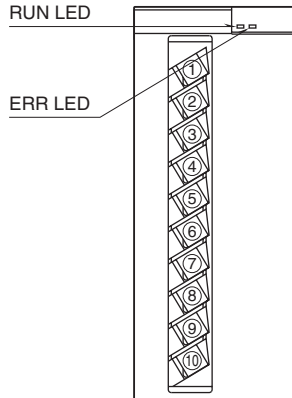

SIDE VIEW

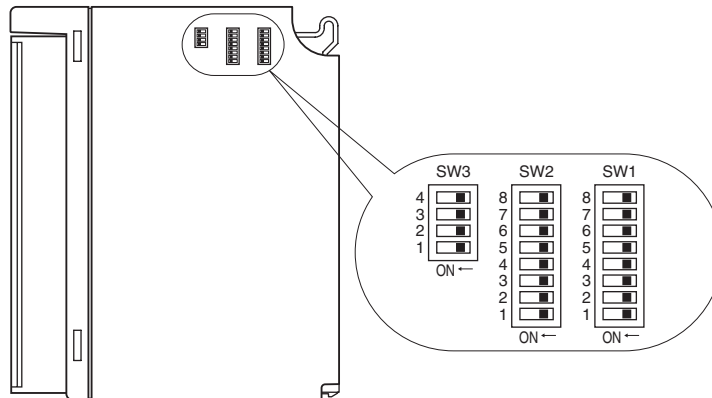

TRANSMISSION DATA DESCRIPTIONS

ADDRESS	CONTENTS
n	Active power *2
n + 1	Reactive power *2
n + 2	Power factor *2
n + 3	Frequency *2
n + 4	Incoming active energy (lower bits)]*3
n + 5	Incoming active energy (upper bits)]
n + 6	Outgoing active energy (lower bits)]*3
n + 7	Outgoing active energy (upper bits)]
n + 8	LAG reactive energy (lower bits)]*3
n + 9	LAG reactive energy (upper bits)]
n + 10	LEAD reactive energy (lower bits)]*3
n + 11	LEAD reactive energy (upper bits)]
n + 12	0
n + 13	0
n + 14	0
n + 15	0
R3CON type ID	WT1****
Network module data allocation mode example *1	4, 8, 16

n = I/O address on the installation base
 Factory setting = 1 kWh and 1 kvarh per bit.
 Data address depends upon the data allocation mode as indicated below:

- 4 (n thr. n+3)
- 8 (n thr. n+7)
- 16 (n thr. n+15)

- *1. Fixed at 16 for the R3-NPx.
- *2. 16-bit data
- *3. 32-bit data

I/O DATA DESCRIPTIONS

16-BIT DATA

16-bit binary data. Minus values are represented in 2's complements.



32-BIT DATA

32-bit binary data. Minus values are represented in 2's complements.

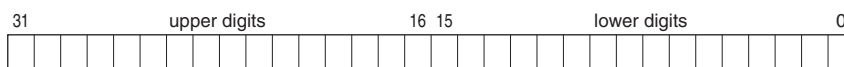

EXTERNAL DIMENSIONS & TERMINAL ASSIGNMENTS unit: mm (inch)

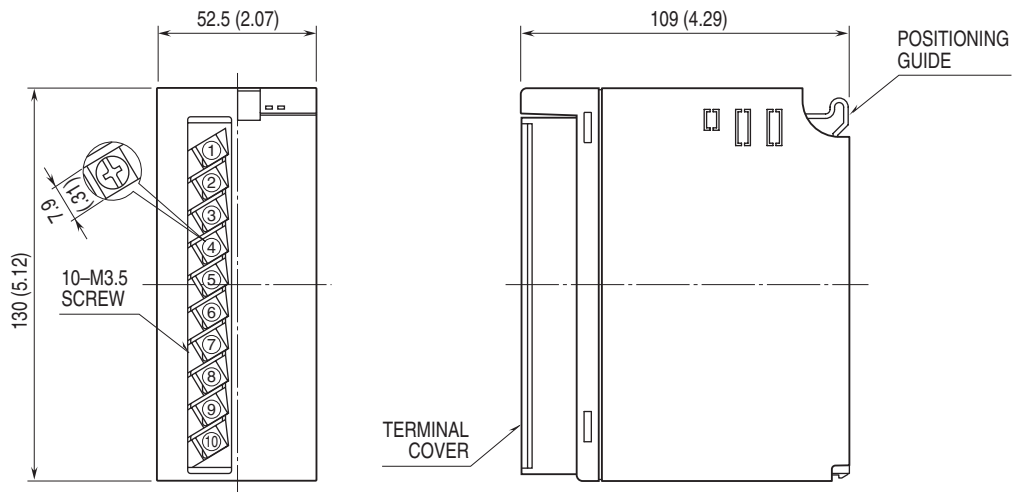

SCHEMATIC CIRCUITRY & CONNECTION DIAGRAM

3-PHASE/3-WIRE

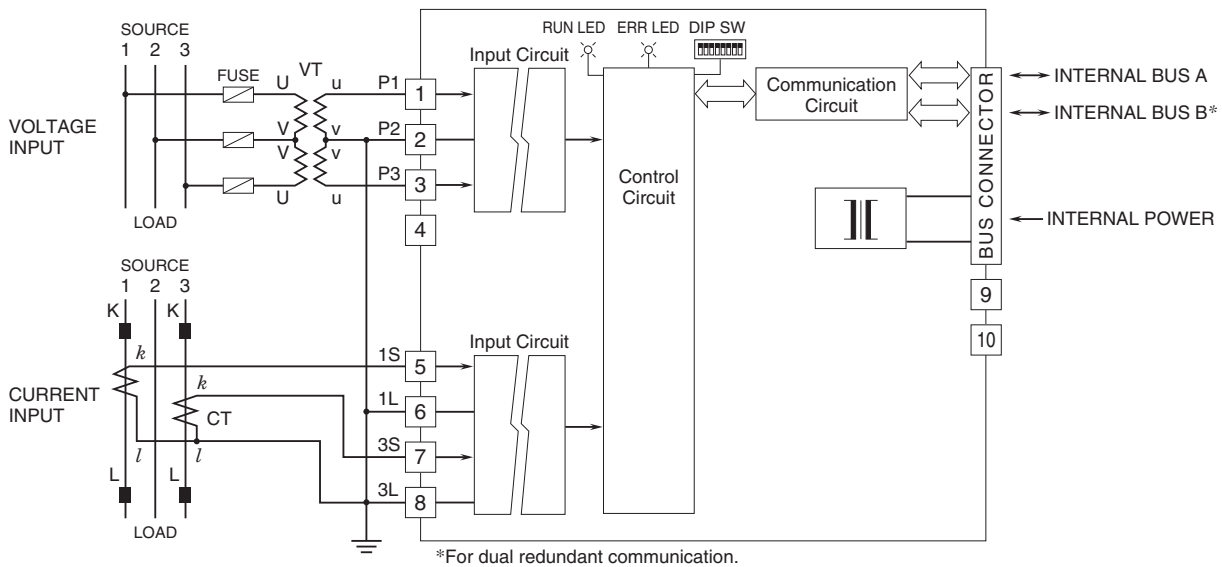

SINGLE-PHASE/2-WIRE

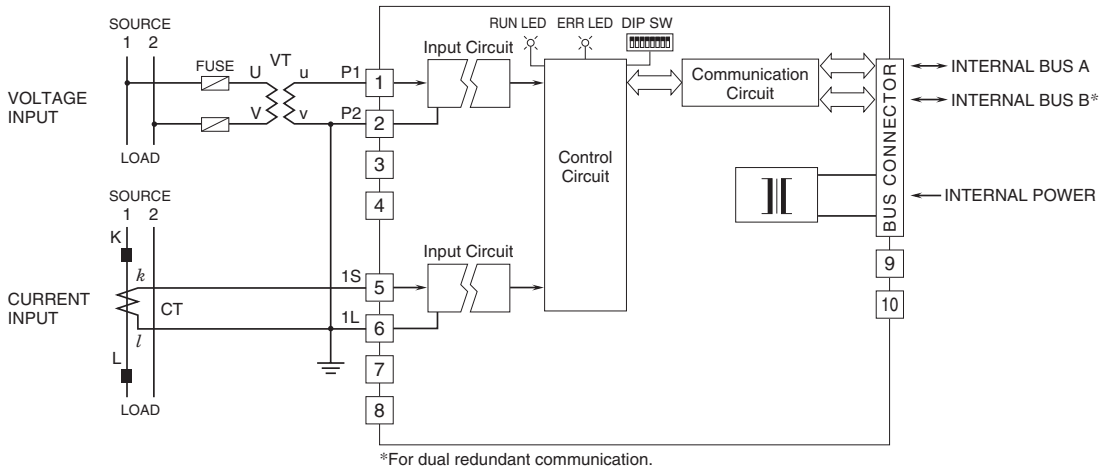

■ SINGLE-PHASE/3-WIRE

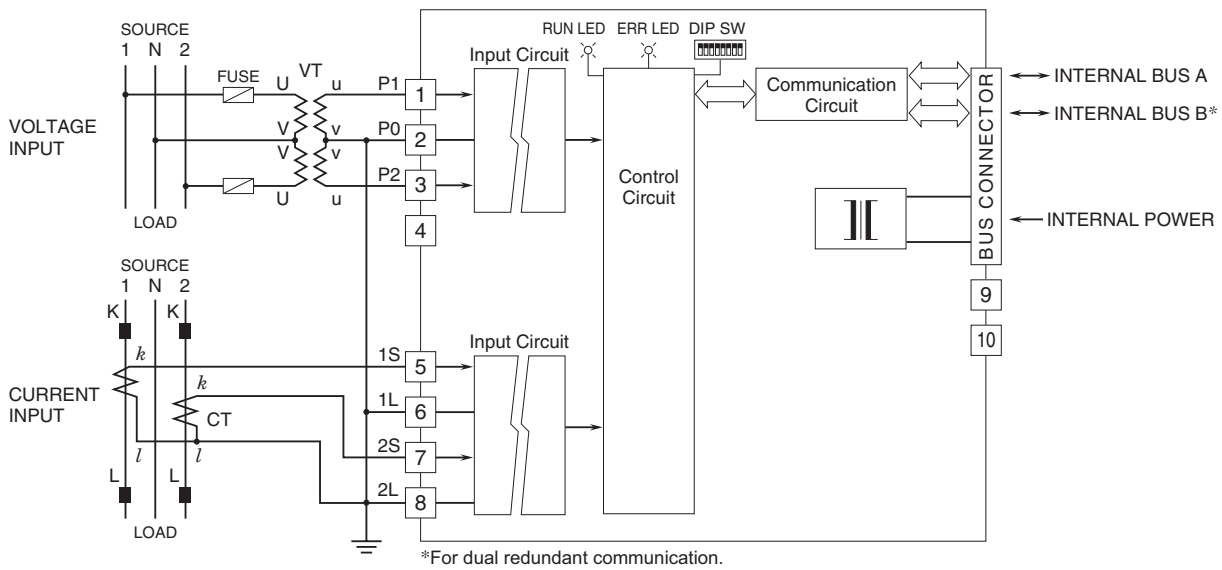

Specifications are subject to change without notice.

