

Remote I/O R3 Series

RTD INPUT MODULE

(8 points, isolated)

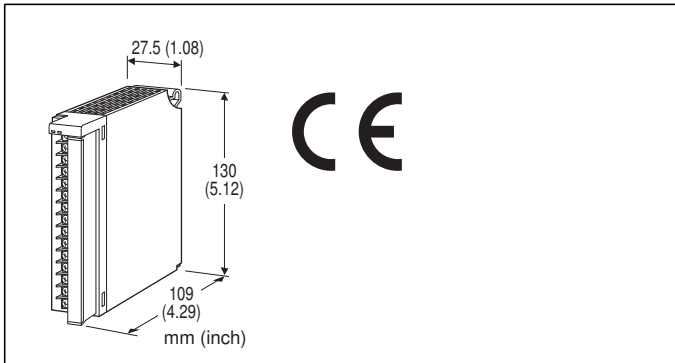

MODEL: R3-RS8A[1][2]

ORDERING INFORMATION

- Code number: R3-RS8A[1][2]
- Specify a code from below for each [1] and [2].
(e.g. R3-RS8AW/CE/Q)
- Specify the specification for option code /Q
(e.g. /C01)

NO. OF CHANNELS

8: 8

[1] COMMUNICATION MODE

S: Single
W: Dual

[2] OPTIONS (multiple selections)

Standards & Approvals

blank: Without CE
/CE: CE marking

Other Options

blank: none
/Q: Option other than the above (specify the specification)

SPECIFICATIONS OF OPTION: Q

COATING (For the detail, refer to M-System's web site.)

/C01: Silicone coating
/C02: Polyurethane coating
/C03: Rubber coating

GENERAL SPECIFICATIONS

Connection
Internal bus: Via the Installation Base (model: R3-BSx)

Input: M3 separable screw terminal (torque 0.5 N·m)
Internal power: Via the Installation Base (model: R3-BSx)
Screw terminal: Nickel-plated steel
Isolation: Input 1 to input 2 to input 3 to input 4 to input 5 to input 6 to input 7 to input 8 to internal bus or internal power
Sensor type: Selectable with the side DIP SW
(Independent types selectable per group of 4 channels.)
Temperature unit: °C or °F selectable with the side DIP SW
Conversion rate: Selectable with the side DIP SW
Burnout detection: Upscale or downscale selectable with the side DIP SW
Linearization: Standard
RUN indicator: Bi-color (red/green) LED;
Red when the bus A operates normally;
Green when the bus B operates normally;
Amber when both buses operate normally.
ERR indicator: Bi-color (red/green) LED;
Red with the burnout; Green in normal operating conditions.

INPUT SPECIFICATIONS

Maximum leadwire resistance: 10 Ω per wire
Sensing current: ≤ 1 mA
Temperature range

RTD	Conformance Range °C	Burnout Values °C × 100
Pt 100 (JIS '97, IEC)	-20 to +100	-24000, +32767
Pt 100 (JIS '89)	-20 to +100	-24000, +32767
JPt 100 (JIS '89)	-20 to +100	-23600, +32767
RTD	Conformance Range °F	Burnout Values °F × 10
Pt 100 (JIS '97, IEC)	-4 to +212	-4000, +16520
Pt 100 (JIS '89)	-4 to +212	-4000, +16520
JPt 100 (JIS '89)	-4 to +212	-3928, +10400

INSTALLATION

Operating temperature: -10 to +55°C (14 to 131°F)
Operating humidity: 30 to 90 %RH (non-condensing)
Atmosphere: No corrosive gas or heavy dust
Mounting: Installation Base (model: R3-BSx)
Weight: 250 g (0.55 lb)

PERFORMANCE

Conversion accuracy: ±0.2°C or ±0.4°F
Conversion rate: 250 msec. or 1 sec. selectable
Data range
°C: Engineering unit value × 100 (integer)
°F: Engineering unit value × 10 (integer)
Data allocation: 8
Current consumption: 100 mA
Temp. coefficient: ±0.015 %/°C (±0.008 %/°F)
Resolution: 0.03°C (0.1°F)



Burnout response time: ≤ 2 sec.

Insulation resistance: ≥ 100 M Ω with 500 V DC

Dielectric strength: 1000 V AC @ 1 minute (input 1 to input 2 to input 3 to input 4 to input 5 to input 6 to input 7 to input 8 to internal bus or internal power)

2000 V AC @ 1 minute (power input to FG; isolated on the power supply module)

STANDARDS & APPROVALS

CE conformity:

EMC Directive (2004/108/EC)

EMI EN 61000-6-4: 2007/A1: 2011

EMS EN 61000-6-2: 2005

EXTERNAL VIEW

■ SIDE VIEW

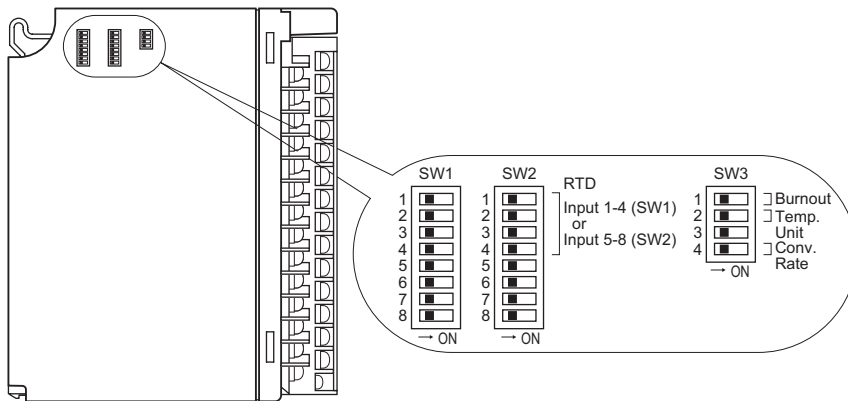

■ FRONT VIEW

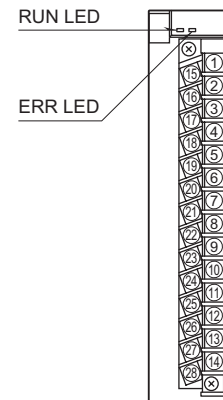

EXTERNAL DIMENSIONS & TERMINAL ASSIGNMENTS unit: mm (inch)

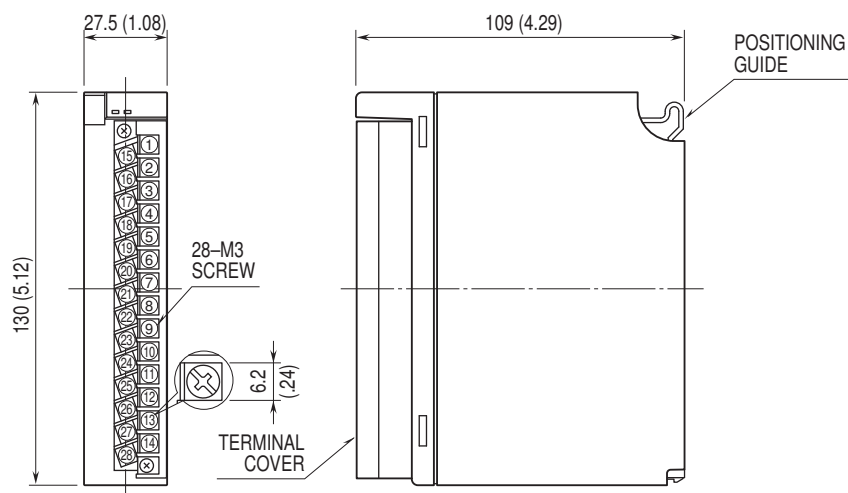

SCHEMATIC CIRCUITRY & CONNECTION DIAGRAM

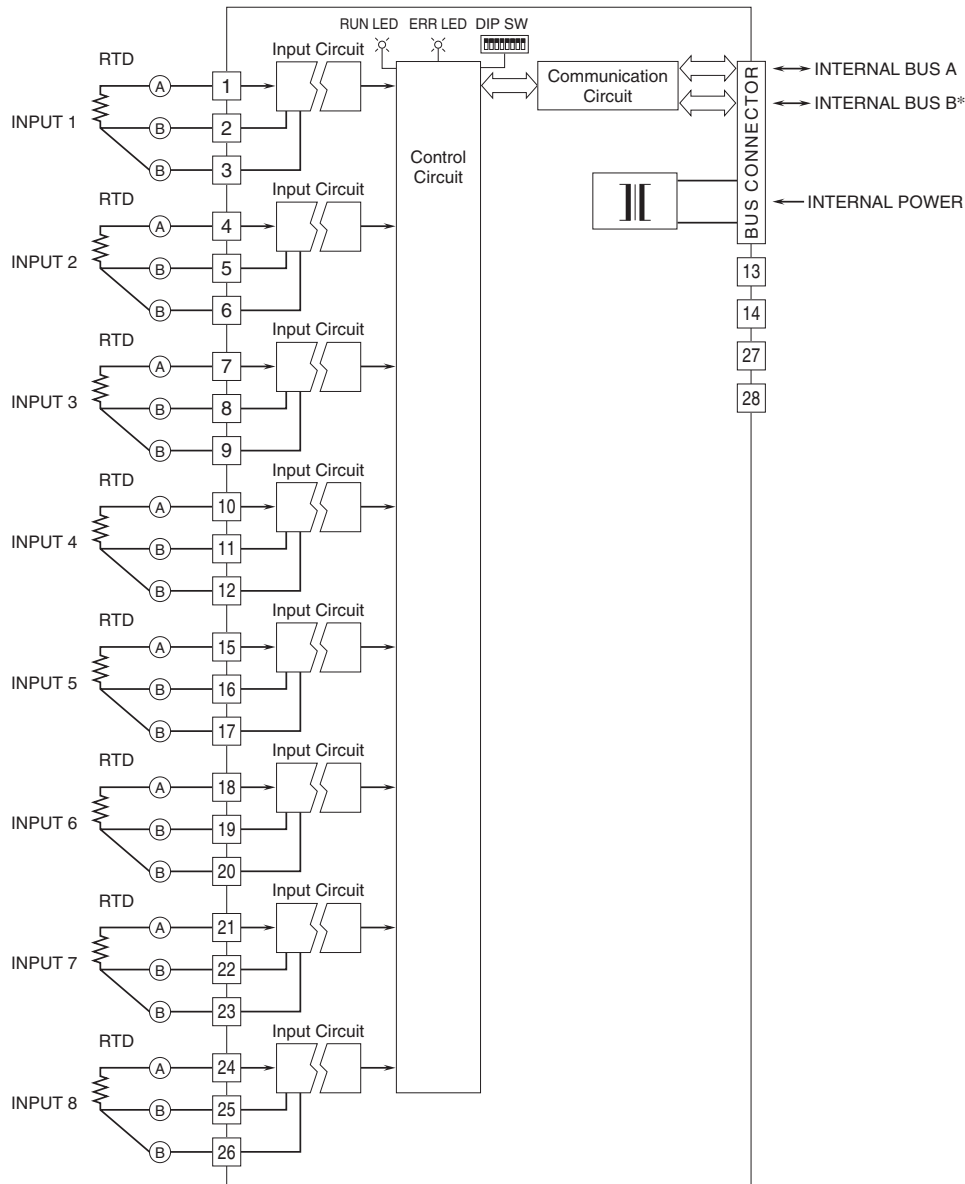

*For dual redundant communication.

• Unused Input Channels

Close across the unused input terminals with a resistor as shown below and set the DIP switch for an RTD. The resistance value must match the RTD type (100Ω for Pt 100).

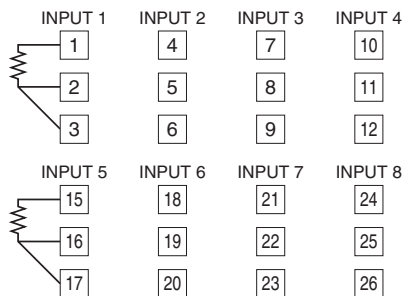

Unused channels left open are equal to the burnout, which turns the red ERR LED on and sets a burnout flag at the PLC or the host device.

Unused channels can be specified and set so on the PC Configurator Software (model: R3CON) without needing to connect resistors at the field terminals.





Specifications are subject to change without notice.

