

Remote I/O R3 Series

RTD INPUT MODULE

(high accuracy, 4 points, isolated)

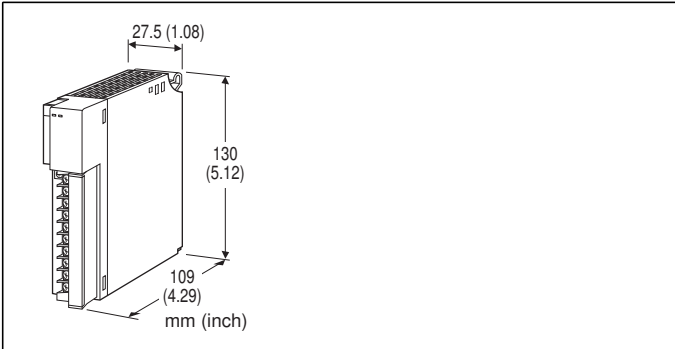

MODEL: R3-RS4A[1][2]

ORDERING INFORMATION

- Code number: R3-RS4A[1][2]
- Specify a code from below for each [1] and [2].
(e.g. R3-RS4AW/Q)
- Specify the specification for option code /Q
(e.g. /C01)

NO. OF CHANNELS

4: 4

[1] COMMUNICATION MODE

S: Single

W: Dual

[2] OPTIONS

blank: none

/Q: With options (specify the specification)

SPECIFICATIONS OF OPTION: Q

COATING (For the detail, refer to M-System's web site.)

/C01: Silicone coating

/C02: Polyurethane coating

/C03: Rubber coating

GENERAL SPECIFICATIONS

Connection

Internal bus: Via the Installation Base (model: R3-BSx)

Input: M3 separable screw terminal (torque 0.5 N·m)

Internal power: Via the Installation Base (model: R3-BSx)

Screw terminal: Nickel-plated steel

Isolation: Input 1 to input 2 to input 3 to input 4 to internal

bus or internal power

Sensor type: Selectable with the side DIP SW

Temperature unit: °C or °F selectable with the side DIP SW

Conversion rate: Selectable with the side DIP SW

Burnout detection: Upscale or downscale selectable with the side DIP SW

Linearization: Standard

RUN indicator: Bi-color (red/green) LED;

Red when the bus A operates normally;

Green when the bus B operates normally;

Amber when both buses operate normally.

ERR indicator: Bi-color (red/green) LED;

Red with the input abnormality;

Green in normal operating conditions.

INPUT SPECIFICATIONS

Maximum leadwire resistance: 10 Ω per wire

Sensing current: ≤ 0.5 mA

Temperature range

RTD	°C	
	CONFORMANCE RANGE (°C)	BURNOUT VALUE (°C × 100)
Pt 100 (JIS '97, IEC)	-50 to +200	-24000, +32767
Pt 100 (JIS '89)	-50 to +200	-24000, +32767
JPt 100 (JIS '89)	-50 to +200	-23600, +32767
Pt 1000	-50 to +200	-24000, +32767

RTD	°F	
	CONFORMANCE RANGE (°F)	BURNOUT VALUE (°F × 10)
Pt 100 (JIS '97, IEC)	-58 to +392	-4000, +6218
Pt 100 (JIS '89)	-58 to +392	-4000, +6218
JPt 100 (JIS '89)	-58 to +392	-3928, +6218
Pt 1000	-58 to +392	-4000, +6218

INSTALLATION

Operating temperature: -10 to +55°C (14 to 131°F)

Operating humidity: 30 to 90 %RH (non-condensing)

Atmosphere: No corrosive gas or heavy dust

Mounting: Installation Base (model: R3-BSx)

Weight: 200 g (0.44 lb)

PERFORMANCE

Conversion accuracy: ±0.2°C or ±0.4°F

Conversion rate: 250 msec. or 1 sec. selectable

Data range

°C: Engineering unit value × 100 (integer)

°F: Engineering unit value × 10 (integer)

Data allocation: 4

Current consumption: 70 mA

Temp. coefficient: ±0.015 %/°C (±0.008 %/°F)

Resolution: 0.03°C (0.1°F)

Burnout response time: ≤ 2 sec.



Insulation resistance: $\geq 100 \text{ M}\Omega$ with 500 V DC
Dielectric strength: 1500 V AC @ 1 minute (input 1 to input 2 to input 3 to input 4 to internal bus or internal power)
 2000 V AC @ 1 minute (power input to FG; isolated on the power supply module)

EXTERNAL VIEW

■ FRONT VIEW

■ SIDE VIEW

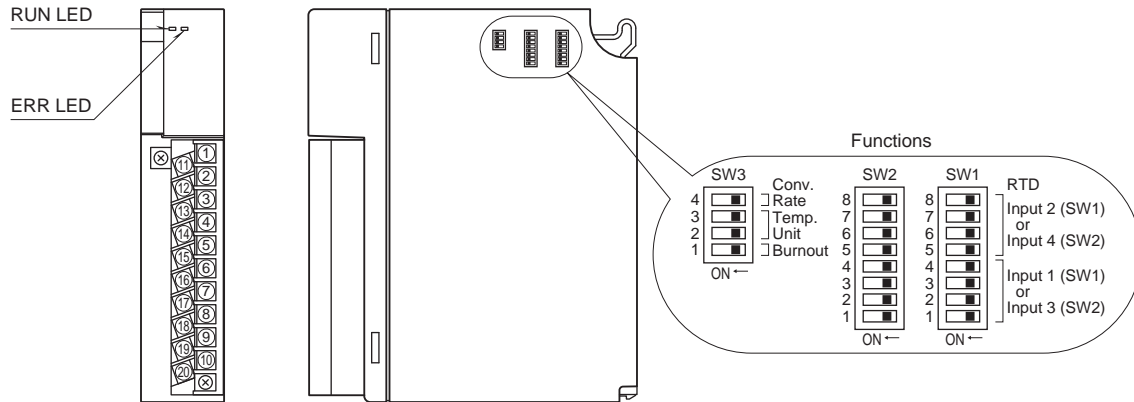

EXTERNAL DIMENSIONS & TERMINAL ASSIGNMENTS unit: mm (inch)

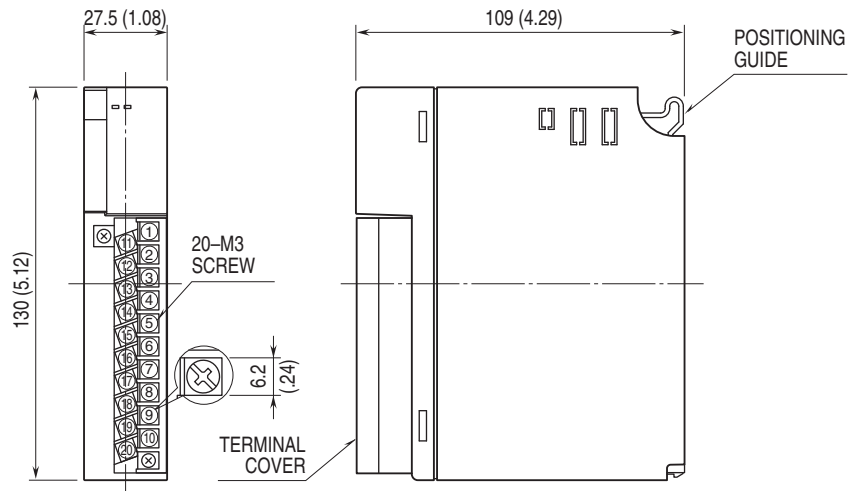

SCHEMATIC CIRCUITRY & CONNECTION DIAGRAM

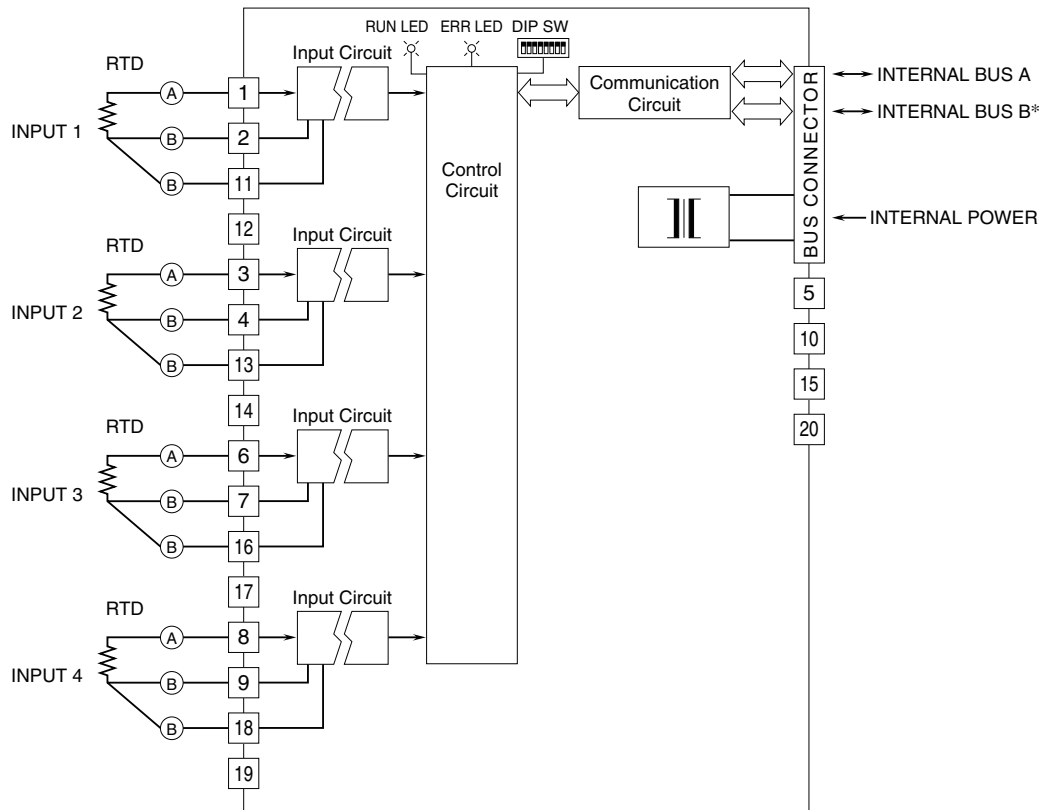

*For dual redundant communication.

• Unused Input Channels

Close across the unused input terminals with a resistor as shown below and set the DIP switch for Pt 100 input.

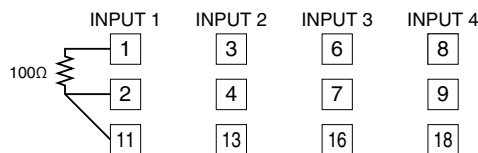

Unused channels left open are equal to the burnout, which turns the red ERR LED on and sets a burnout flag at the PLC or the host device.

Unused channels can be specified and set so on the PC Configurator Software (model: R3CON) without needing to connect resistors at the field terminals.



Specifications are subject to change without notice.