

## Remote I/O R3 Series

/C03: Rubber coating

### PROFIBUS-DP INTERFACE MODULE

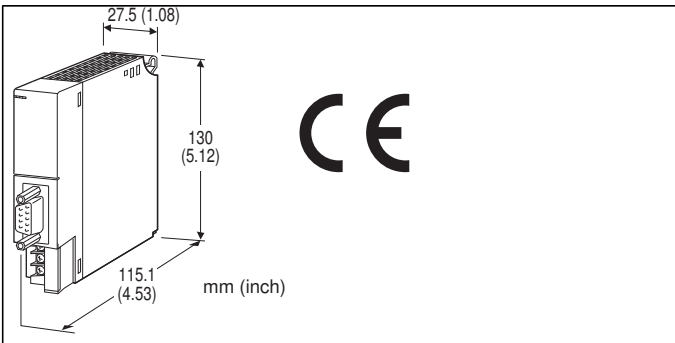

### MODEL: R3-NP1-[1][2]

#### ORDERING INFORMATION

Code number: R3-NP1-[1][2]

Specify a code from below for each [1] and [2].

(e.g. R3-NP1-R/CE/Q)

- Specify the specification for option code /Q (e.g. /C01)

#### [1] POWER INPUT

**N:** No power supply

##### AC Power

**K3:** 100 - 120 V AC

(Operational voltage range 85 - 132 V, 47 - 66 Hz) \*  
(CE not available)

**L3:** 200 - 240 V AC

(Operational voltage range 170 - 264 V, 47 - 66 Hz) \*  
(CE not available)

##### DC Power

**R:** 24 V DC

(Operational voltage 24 V  $\pm$ 10 %, ripple 10 %p-p max.) \*

\* Not selectable for use with independent power modules.  
Not selectable for dual network.

#### [2] OPTIONS (multiple selections)

##### Standards & Approvals

**blank:** Without CE

/CE: CE marking

##### Other Options

**blank:** none

/Q: Option other than the above (specify the specification)

#### SPECIFICATIONS OF OPTION: Q

**COATING (For the detail, refer to M-System's web site.)**

/C01: Silicone coating

/C02: Polyurethane coating

#### GENERAL SPECIFICATIONS

##### Connection

**Network:** 9-pin D-sub connector, female

**Internal bus:** Via the Installation Base

(model: R3-BSx)

**Internal power:** Via the Installation Base

(model: R3-BSx) or M3 separable screw terminal (torque 0.5 N·m)

**RUN contact output:** M3 separable screw terminal (torque 0.5 N·m)

**Screw terminal:** Nickel-plated steel

**Isolation:** PROFIBUS to internal bus or internal power to power supply to RUN contact output to FG

**Input error data:** Input value setting at input module error with side DIP SW

**Main/Sub setting:** Set with the side DIP switch

**RUN indicator:** Bi-color (green/Amber) LED

(Function selected with DIP SW)

**ERR indicator:** Bi-color (green/red) LED

(Function selected with DIP SW)

**RUN contact:** Turns ON while the green RUN LED is ON. (PROFIBUS in normal communication)

##### ■ RUN CONTACT OUTPUT

**Rated load:** 250 V AC @ 0.5 A ( $\cos \phi = 1$ )

30 V DC @ 0.5 A (resistive load)

(Max. 50 V AC to conform with EC Directive)

**Maximum switching voltage:** 250 V AC or 30 V DC

**Maximum switching power:** 250 VA or 150 W

**Minimum load:** 1 V DC @ 1 mA

**Mechanical life:**  $2 \times 10^7$  cycles (300 cycles/min.)

When driving an inductive load, external contact protection and noise quenching recommended.

#### PROFIBUS COMMUNICATION

**Interface:** PROFIBUS-DP, slave (RS-485 isolation)

**Max. baud rate:** 12 Mbps

**Protocol:** DPV1

**Station No. setting:** Rotary switch; 00 - 7D

(Address is 7D even setting greater value)

**GSD file:** Msys093F.GSD

GSD files are downloadable at M-System's web site or at PROFIBUS International site ([www.profibus.com](http://www.profibus.com)).

**Input data:** Max. 240 bytes

**Output data:** Max. 240 bytes

**Total I/O data:** Max. 480 bytes

**Diagnostics:** Module-related, Status (device-related),

Channel-related (max. 32 channels, maskable)

**Acyclic communication (MSAC2):** 2 channels



## INSTALLATION

### Power consumption

- AC: Approx. 20 VA
- DC: Approx. 12 W

**Current consumption (no power supply):** 130 mA

**Output current (power supply):** 220 mA continuous at 20 V

DC; 370 mA for 10 minutes

**Operating temperature:** -10 to +55°C (14 to 131°F)

**Operating humidity:** 30 to 90 %RH (non-condensing)

**Atmosphere:** No corrosive gas or heavy dust

**Mounting:** Installation Base (model: R3-BSx)

**Weight:** 200 g (0.44 lb)

## PERFORMANCE

**Insulation resistance:**  $\geq 100 \text{ M}\Omega$  with 500 V DC

**Dielectric strength:** 1500 V AC @ 1 minute (PROFIBUS to internal bus or internal power to power input to RUN output to FG)

## STANDARDS & APPROVALS

### CE conformity:

EMC Directive (2004/108/EC)

EMI EN 61000-6-4: 2007/A1: 2011

EMS EN 61000-6-2: 2005

## EXTERNAL VIEW

### FRONT VIEW

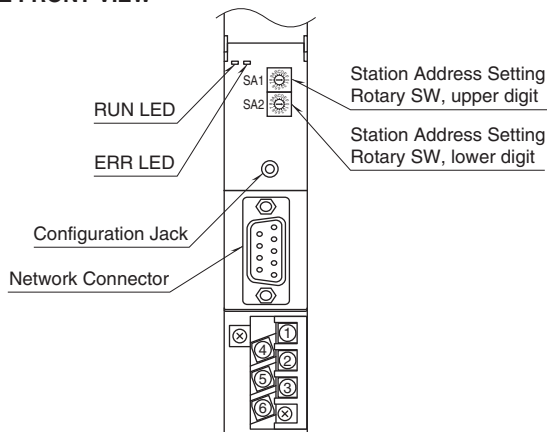

### SIDE VIEW

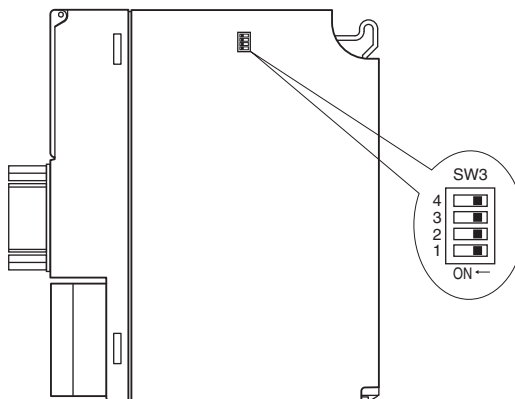

### PROFIBUS INTERFACE

PIN No.	SIGNAL	SIGNIFICANCE
1	NC	Not used
2	NC	Not used
3	B_line	Network, B-line
4	RTS	RTS signal
5	GND	0V
6	P5V	5V
7	NC	Not used
8	A_line	Network, A-line
9	NC	Not used

## I/O DATA DESCRIPTIONS

### ■ ANALOG DATA (models: R3-SV4, YV4, DS4, YS4, US4, etc.)

16-bit binary data.

Basically, 0 to 100% of the selected I/O range is converted into 0 to 10000 (binary). Negative percentage is represented in 2's complements.



### ■ TEMPERATURE DATA (models: R3-RS4, TS4, US4, etc.)

16-bit binary data.

With °C temperature unit, raw data is multiplied by 10. For example, 25.5°C is converted into 255.

With °F temperature unit, the integer section of raw data is directly converted into the data.

For example, 135.4°F is converted into 135.

Minus temperature is converted into negative values, represented in 2's complements.



### ■ 16-POINT DISCRETE DATA (models: R3-DA16, DC16, etc.)

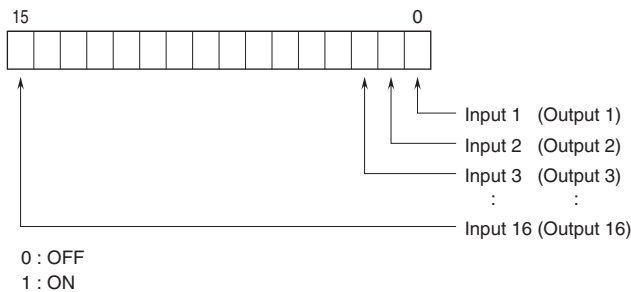

## EXTERNAL DIMENSIONS & TERMINAL ASSIGNMENTS unit: mm (inch)

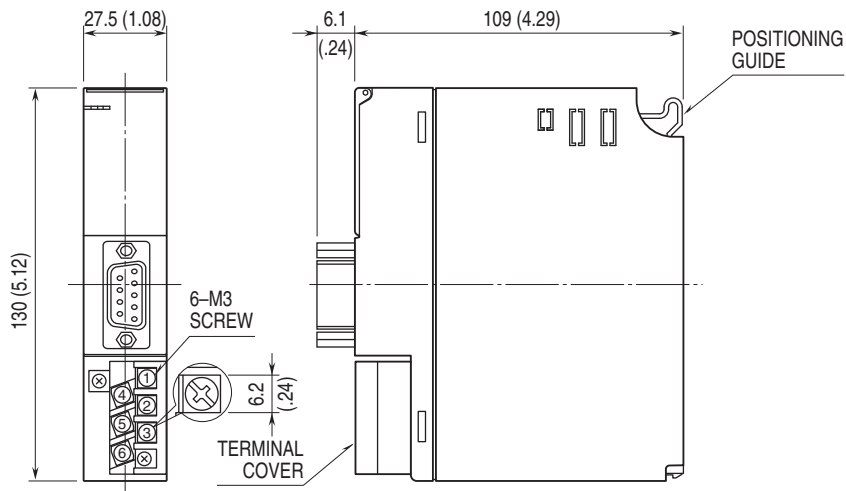

## SCHEMATIC CIRCUITRY & CONNECTION DIAGRAM

Note: In order to improve EMC performance, bond the FG terminal to ground.

Caution: FG terminal is NOT a protective conductor terminal.

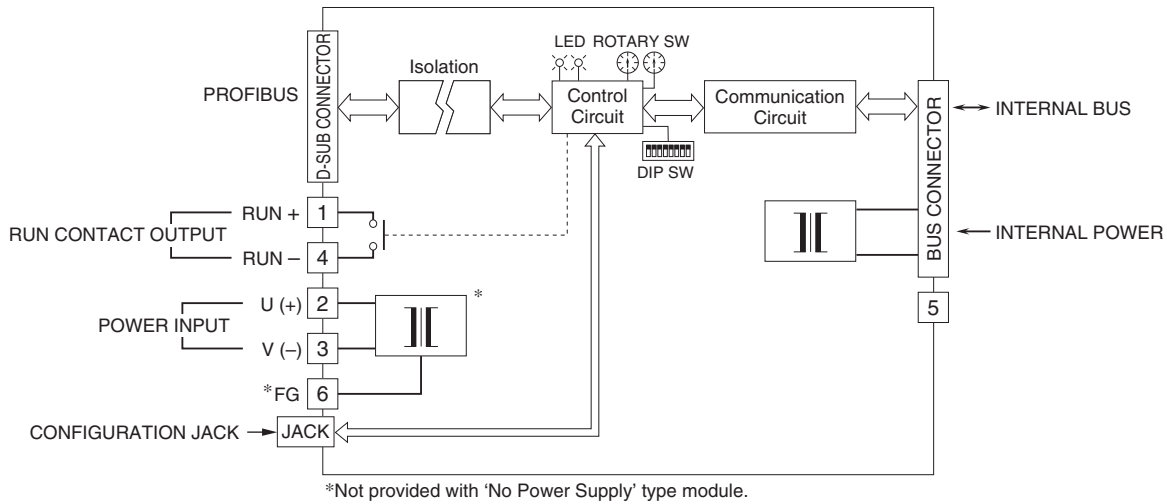

Specifications are subject to change without notice.