

## Remote I/O R3 Series

### MODBUS INTERFACE MODULE

(For temperature control module)

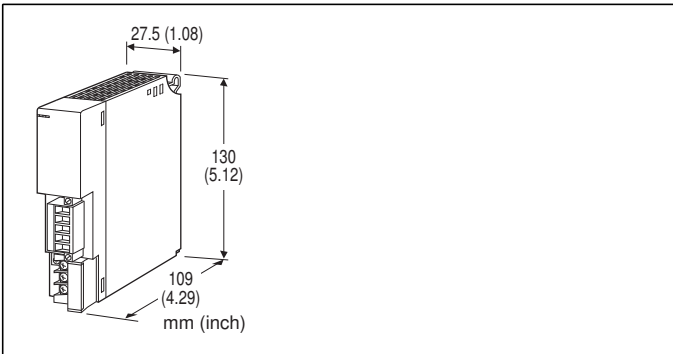

### MODEL: R3-NM3-[1][2]

#### ORDERING INFORMATION

- Code number: R3-NM3-[1][2]
- Specify a code from below for each [1] and [2].  
(e.g. R3-NM3-R/Q)
- Specify the specification for option code /Q  
(e.g. /C01/SET)

#### [1] POWER INPUT

**N:** No power supply

##### AC Power

**K3:** 100 - 120 V AC

(Operational voltage range 85 - 132 V, 47 - 66 Hz) \*

**L3:** 200 - 240 V AC

(Operational voltage range 170 - 264 V, 47 - 66 Hz) \*

##### DC Power

**R:** 24 V DC

(Operational voltage 24 V  $\pm$ 10 %, ripple 10 %p-p max.) \*

\* Not selectable for use with independent power modules.  
Not selectable for dual network.

#### [2] OPTIONS

blank: none

/Q: With options (specify the specification)

#### SPECIFICATIONS OF OPTION: Q (multiple selections)

##### COATING (For the detail, refer to M-System's web site.)

/C01: Silicone coating

/C02: Polyurethane coating

/C03: Rubber coating

##### EX-FACTORY SETTING

/SET: Preset according to the Ordering Information Sheet  
(No. ESU-8354)

#### PACKAGE INCLUDES...

- Terminating resistor (110  $\Omega$ , 0.25 W)

#### GENERAL SPECIFICATIONS

##### Connection

**Network:** Euro type connector terminal

**Internal bus:** Via the Installation Base  
(model: R3-BSx)

**Internal power:** Via the Installation Base (model: R3-BSx)

**Power input, RUN contact output:** M3 separable screw terminal (torque 0.5 N·m)

**Screw terminal:** Nickel-plated steel

**Isolation:** Modbus to internal bus or internal power to power input to RUN contact output to FG

**Input error data:** Input value setting at input module error with side DIP SW

**Main/Sub switching control in dual communication mode:** Selectable with the side DIP SW (refer to the manual)

**Main/Sub setting:** Set with the side DIP switch

**Slot assignment:** Set with the side DIP switch

**RUN indicator:** Bi-color (green/red) LED; Green ON in normal communication, Red ON when receiving  
(Function selected with DIP SW)

**ERR indicator:** Bi-color (green/red) LED; Green blinking / ON (0.1 sec.) in communication or setting error; Red when transmitting  
(Function selected with DIP SW)

##### ■ RUN CONTACT OUTPUT

• ON when RUN indicator is green (Modbus in normal communication)

**Rated load:** 250 V AC @ 0.5 A (cos  $\phi$  = 1)

30 V DC @ 0.5 A (resistive load)

**Maximum switching voltage:** 250 V AC or 30 V DC

**Maximum switching power:** 250 VA or 150 W

**Minimum load:** 1 V DC @ 1 mA

**Mechanical life:**  $2 \times 10^7$  cycles (300 cycles/min.)

When driving an inductive load, external contact protection and noise quenching recommended.

#### MODBUS COMMUNICATION

##### RS485

**Standard:** Conforms to RS-485, EIA

**Transmission distance:** 500 meters max.

**Transmission media:** Shielded twisted-pair cable (CPEV-S 0.9 dia.)

**Transmission setting:** DIP switch (front)

**Data:** RTU (Binary) or ASCII

**Parity:** None, even or odd

**Baud rate:** 4800, 9600, 19.2 k, 38.4 k (bps)

**Node address:** Rotary switch; 01 - F7



## INSTALLATION

### Power consumption

- AC: Approx. 20 VA
- DC: Approx. 12 W

**Current consumption (no power supply):** 100 mA

**Output current (power supply):** 250 mA continuous at 20 V

DC; 400 mA for 10 minutes

**Operating temperature:** -10 to +55°C (14 to 131°F)

**Operating humidity:** 30 to 90 %RH (non-condensing)

**Atmosphere:** No corrosive gas or heavy dust

**Mounting:** Installation Base (model: R3-BSx)

**Weight:** 200 g (0.44 lb)

## PERFORMANCE

**Insulation resistance:**  $\geq 100 \text{ M}\Omega$  with 500 V DC

**Dielectric strength:** 1500 V AC @ 1 minute (Modbus through internal bus or internal power to power input to RUN contact output to FG)

## EXTERNAL VIEW

### FRONT VIEW

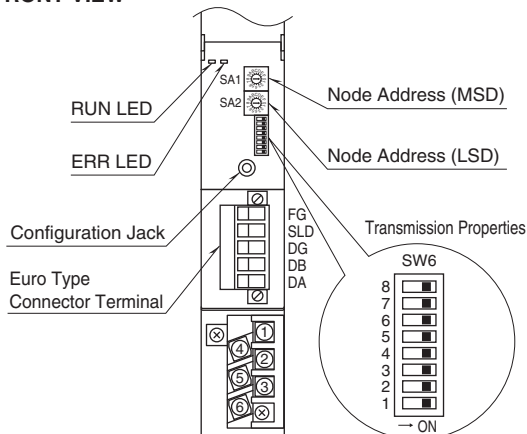

### SIDE VIEW

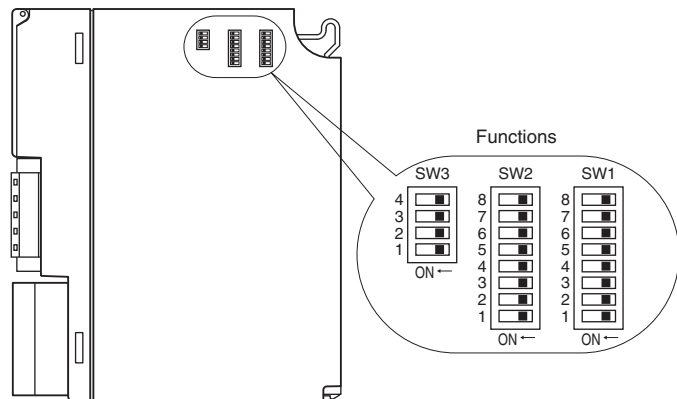

## COMMUNICATION CABLE CONNECTIONS

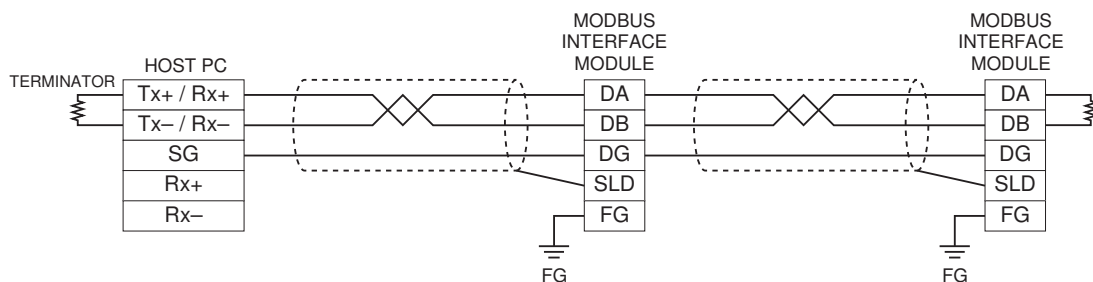

**MODBUS FUNCTION CODES & SUPPORTED CODES****■ DATA & CONTROL FUNCTIONS**

CODE	NAME		
01	Read Coil Status	X	Digital output from the slave (read/write)
02	Read Input Status	X	Status of digital inputs to the slave (read only)
03	Read Holding Registers	X	General purpose register within the slave (read/write)
04	Read Input Registers	X	Collected data from the field by the slave (read only)
05	Force Single Coil	X	Digital output from the slave (read/write)
06	Preset Single Registers	X	General purpose register within the slave (read/write)
07	Read Exception Status		
08	Diagnostics	X	
09	Program 484		
10	Poll 484		
11	Fetch Comm. Event Counter	X	Fetch a status word and an event counter
12	Fetch Comm. Event Log	X	A status word, an event counter, a message count and a field of event bytes
13	Program Controller		
14	Poll Controller		
15	Force Multiple Coils	X	Digital output from the slave (read/write)
16	Preset Multiple Registers	X	General purpose register within the slave (read/write)
17	Report Slave ID	X	Slave type/ 'RUN' Status
18	Program 884/M84		
19	Reset Comm. Link		
20	Read General Reference		
21	Write General Reference		
22	Mask Write 4X Register		
23	Read/Write 4X Register		
24	Read FIFO Queue		

**■ Exception Codes**

CODE	NAME		
01	Illegal Function	X	Function code is not allowable for the slave
02	Illegal Data Address	X	Address is not available within the slave
03	Illegal Data Value	X	Data is not valid for the function
04	Slave Device Failure	X	
05	Acknowledge	X	
06	Slave Device Busy	X	
07	Negative Acknowledge	X	
08	Memory Parity Error		

**■ DIAGNOSTIC SUBFUNCTIONS**

CODE	NAME		
00	Return Query Data	X	Loop back test
01	Restart Comm. Option	X	Reset the slave and clear all counters
02	Return Diagnostic Register	X	Contents of the diagnostic data (2 bytes)
03	Change ASCII Input Delimiter	X	Delimiter character of ASCII message
04	Force Listen Only Mode	X	Force the slave into Listen Only Mode



## MODBUS I/O ASSIGNMENTS

	ADDRESS	DATA FORMAT	NAME
Coil (0X)	1 – 1024		Digital Output (discrete output)
	1025		Main / Sub Switching Command (valid only with SW3-3 set to ON)
Inputs (1X)	1 – 1024		Digital Input (discrete input)
	1025 – 1040		Module Status
	1041 – 1056		Error Status
	1057 – 1072		Data Error Status
Input Registers (3X)	1 – 256	I	Analog Input
	257 – 768	F	Analog Input
Holding Registers (4X)	1 – 256	I	Analog Output
	257 – 768	F	Analog Output
	2001 – 50000		Extension I/O

I : Integer, 0 – 10000 (0 – 100%)

F : Floating (32-bit data cannot be accessed using floating addresses.)

Note: DO NOT access addresses other than mentioned above. Such access may cause problems such as inadequate operation.

- Module Status indicates whether individual I/O module are mounted or not. The bit corresponding to the mounted slots turns to “1,” and the unmounted slots to “0.”
- Error Status indicates error status for each module as described below. The bit corresponding to such modules turns to “1.”
  - R3-TSx, -RSx, -US4: Input burnout
  - R3-DA16A: Power input in error or disconnected
  - R3-YSx: Output current error (e.g. load unconnected)
- Data Error Status indicates overrange (R3-US4: out of -10% to +110%; the other types: out of -15% to +115%) status for each module. The bit corresponding to such modules turns to “1.”
- Main / Sub Switching Commands given to the network modules result as follows:

‘MAIN’ MODULE	‘SUB’ MODULE	OUTPUT MODE
1	0	Main bus is used; Red light turns on at RUN LED of the I/O modules.
0	1	Sub bus is used; Green light turns on at RUN LED of the I/O modules.
1	1	Main bus is used; Amber light turns on at RUN LED of the I/O modules.
0	0	Output is invalid; RUN LED of the I/O modules turns off.

- For Extension I/O, the mapping of 3000 words per each I/O module is available as shown in the table below. The mapping contents depends on each module characteristics; refer to each instruction manual.

SLOT	ADDRESS
1	200 1 – 5000
2	500 1 – 8000
3	800 1 – 11000
4	1100 1 – 14000
:	:
14	4400 1 – 47000
15	4700 1 – 50000



## TRANSMISSION DATA DESCRIPTIONS

The DIP SW located at the side of the module specifies each I/O module's data allocation (occupied data area).  
For example, when the data areas are assigned as shown below:

Module 1	4
Module 2	4
Module 3	4
Module 4	1
Module 5	1
Module 6	1
Module 7	1

Then the I/O data are assigned as in the table below:

	ADDRESS	POSITION
Input Registers (3X)	1 – 4, 257 – 264	Slot 1
Holding Registers (4X)	5 – 8, 265 – 272	Slot 2
	9 – 12, 273 – 280	Slot 3
	13, 281 – 282	Slot 4
	14, 283 – 284	Slot 5
	15, 285 – 286	Slot 6
	16, 287 – 288	Slot 7

	ADDRESS	POSITION
Coil (0X) Inputs (1X)	1 – 64	Slot 1
	65 – 128	Slot 2
	129 – 192	Slot 3
	193 – 208	Slot 4
	209 – 224	Slot 5
	225 – 240	Slot 6
	241 – 256	Slot 7

For Coil (0X) and Inputs (1X), addresses 16 times assigned data areas (Data Allocation Type) are allotted with the Data Allocation Type '1' and '4.' With '8' and '16,' 64 (4 × 16) are automatically assigned.

## I/O DATA DESCRIPTIONS

### ■ MODULE STATUS, ERROR STATUS, DATA ERROR STATUS

Shows each module's availability and error status.

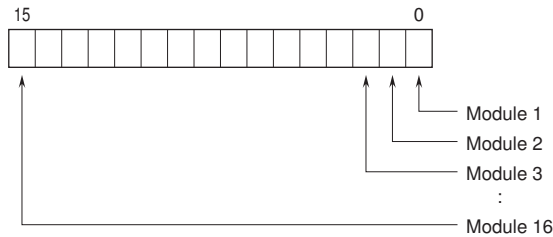

### ■ ANALOG DATA (models: R3-SV4, YV4, DS4, YS4, US4, etc.)

16-bit binary data.

Basically, 0 to 100% of the selected I/O range is converted into 0 to 10000 (binary). Negative percentage is represented in 2's complements.



### ■ TEMPERATURE DATA (models: R3-RS4, TS4, US4, etc.)

16-bit binary data.

With °C temperature unit, raw data is multiplied by 10. For example, 25.5°C is converted into 255.

With °F temperature unit, the integer section of raw data is directly converted into the data.

For example, 135.4°F is converted into 135.

Minus temperature is converted into negative values, represented in 2's complements.



## ■ ACCUMULATED COUNT DATA (32-bit data, models: R3-PA2, PA4A, WT1, WT4, etc.)

32-bit binary data is used for accumulated counts and encoder positions.  
 Lower 16 bits are allocated from the lowest address to higher ones, higher 16 bits in turn.  
 32-bit data cannot be accessed using floating addresses.

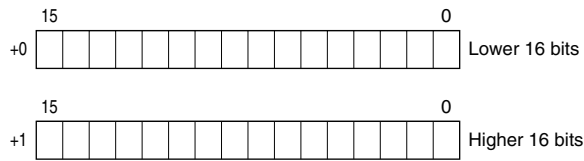

## ■ BCD DATA (32-bit data, models: R3-BA32A, BC32A, etc.)

32-bit binary data is used for BCD.  
 Lower 16 bits are allocated from the lowest address to higher ones, higher 16 bits in turn.  
 32-bit data cannot be accessed using floating addresses.



## ■ 16-POINT DISCRETE DATA (models: R3-DA16, DC16, etc.)

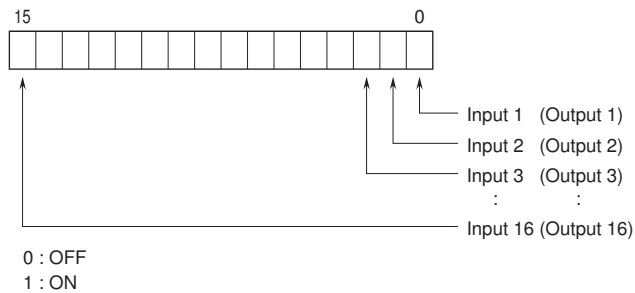

## EXTERNAL DIMENSIONS & TERMINAL ASSIGNMENTS unit: mm (inch)

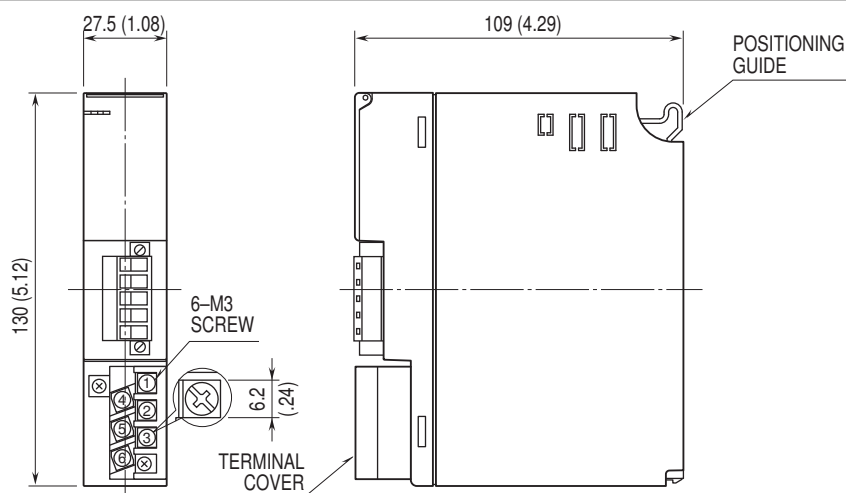

**SCHEMATIC CIRCUITRY & CONNECTION DIAGRAM**

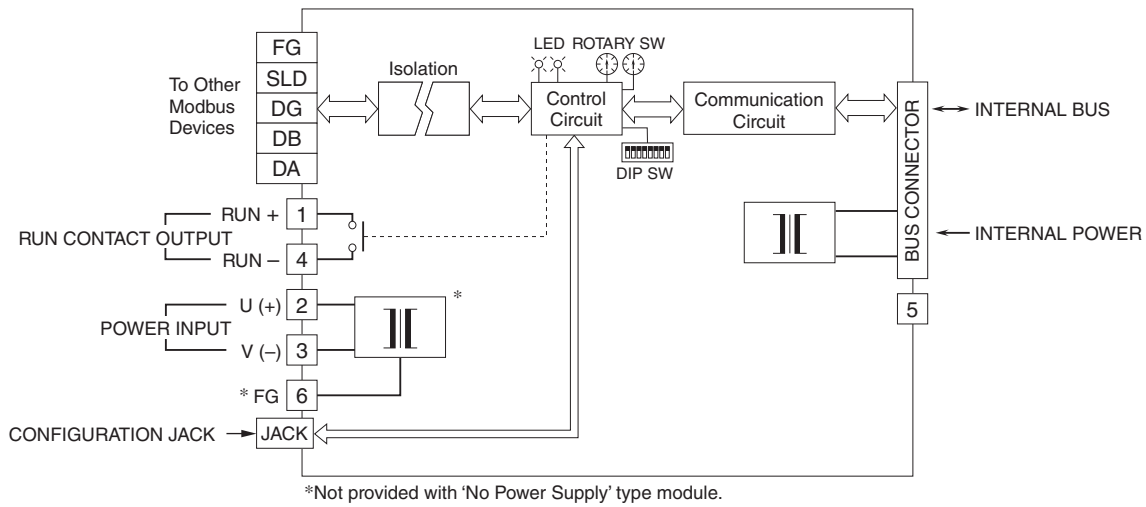

Specifications are subject to change without notice.

