

Remote I/O R3 Series

LonWorks INTERFACE MODULE

(I/O 56 points)

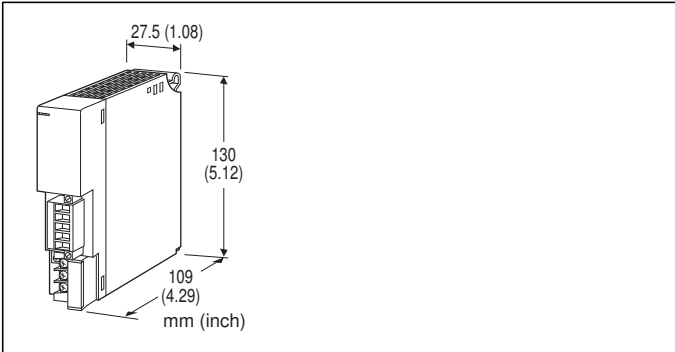

MODEL: R3-NL2-[1][2]

ORDERING INFORMATION

- Code number: R3-NL2-[1][2]
- Specify a code from below for each [1] and [2].
(e.g. R3-NL2-R/Q)
- Specify the specification for option code /Q
(e.g. /C01)

[1] POWER INPUT

N: No power supply

AC Power

K3: 100 - 120 V AC

(Operational voltage range 85 - 132 V, 47 - 66 Hz) *

L3: 200 - 240 V AC

(Operational voltage range 170 - 264 V, 47 - 66 Hz) *

DC Power

R: 24 V DC

(Operational voltage 24 V \pm 10 %, ripple 10 %p-p max.) *

* Not selectable for use with independent power modules.

[2] OPTIONS

blank: none

/Q: With options (specify the specification)

SPECIFICATIONS OF OPTION: Q

COATING (For the detail, refer to M-System's web site.)

/C01: Silicone coating

/C02: Polyurethane coating

/C03: Rubber coating

RELATED PRODUCTS

- XIF File (Device Interface File)

XIF file is used to define a LonWorks device when programmed on LonMaker.

GENERAL SPECIFICATIONS

Connection

Network: Euro type connector terminal

Internal bus: Via the Installation Base

(model: R3-BSx)

Internal power: Via the Installation Base (model: R3-BSx)

Power input, RUN contact output: M3 separable screw terminal (torque 0.5 N·m)

Screw terminal: Nickel-plated steel

Isolation: LonWorks to internal bus or internal power to power input to RUN contact output to FG

Input error data: Input value setting at input module error with side DIP SW

Slot assignment: Set with the side DIP switch

RUN indicator: Bi-color (green/red) LED; Green ON in communications with another device on-line or changing the output data

(turns off after 25 seconds of no communication)

ERR indicator: Bi-color (green/red) LED; Green ON in normal status; Green blinks when

the APB file is not adequately imported;

Green/Orange turn ON in turn in an abnormality.

RUN contact: Turns on while the green RUN LED is ON

(LonWorks in normal communication)

■ RUN CONTACT OUTPUT

Rated load: 250 V AC @ 0.5 A (cos ϕ = 1)

30 V DC @ 0.5 A (resistive load)

Maximum switching voltage: 250 V AC or 30 V DC

Maximum switching power: 250 VA or 150 W

Minimum load: 1 V DC @ 1 mA

Mechanical life: 2×10^7 cycles (rate 300 cycles/min.) When driving an inductive load, external contact protection and noise quenching recommended.

LonWorks COMMUNICATION

Neuron Chip: FT3120 (NeuronID printed in numbers and bar code [peel-off code 39 format])

Transceiver: FT-X1 (equivalent to FTT10A)

Transmission speed: 78 kbps

Twisted-pair cable

Distance, free topology: 500 meters

Max. 64 nodes/channel

LNS: Ver. 3.0 Service Pack 8 or higher

ONLINE indicator: Red LED

ON: Off-line or no network information (decommissioned)

Blinking in approx. 0.5 Hz: On-line



(ready to communicate network variables)

Blinking in approx. 5 Hz for 12 sec:

Wink message received

SERVICE indicator: Green LED

OFF: Normal operations

Blinking in approx. 0.5 Hz: No network information

ON: Internal program error

SERVICE switch: Used to identify the node in LonWorks network configuration

RESET switch: Resetting the Neuron Chip

Possible I/O combinations

Analog I/O

Input	Output	Network Variable Type
56	0	SNVT_lev_percent
0	56	SNVT_lev_percent
32	24	SNVT_lev_percent (factory default)

Temperature Input (°C input module use)

Input	Output	Network Variable Type
56	0	SNVT_temp
56	0	SNVT_temp_p

Discrete I/O (Usable with the R3-DA16x and the R3-DC16x)

Input	Output	Network Variable Type
56	0	SNVT_switch
0	56	SNVT_switch
32	24	SNVT_switch

Totalized Pulse I/O (Usable as analog I/O)

Input	Output	Network Variable Type
56	0	SNVT_count
0	56	SNVT_count
32	24	SNVT_count

Totalized Pulse Input, Discrete I/O (Totalized pulse usable as analog input) (Usable with the R3-DA16x and the R3-DC16x)

Totalized Pulse Input	Discrete		Network Variable Type
	Input	Output	
16	16	16	SNVT_count SNVT_switch

PERFORMANCE

Insulation resistance: $\geq 100 \text{ M}\Omega$ with 500 V DC

Dielectric strength: 1500 V AC @ 1 minute (LonWorks or internal bus or internal power to power input to RUN contact output to FG)

INSTALLATION

Power consumption

•AC: Approx. 20 VA

•DC: Approx. 12 W

Current consumption (no power supply): 100 mA

Output current (power supply): 250 mA continuous at 20 V

DC; 400 mA for 10 minutes

Operating temperature: -10 to +55°C (14 to 131°F)

Operating humidity: 30 to 90 %RH (non-condensing)

Atmosphere: No corrosive gas or heavy dust

Mounting: Installation Base (model: R3-BSx)

Weight: 200 g (0.44 lb)



EXTERNAL VIEW

FRONT VIEW

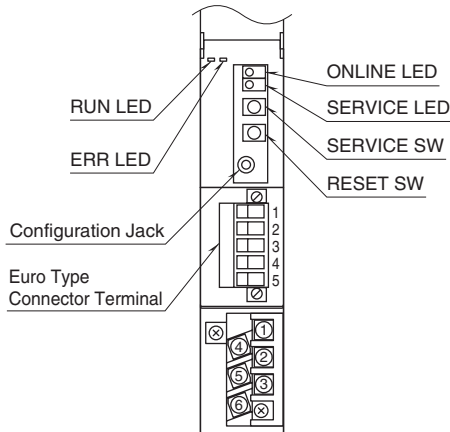

SIDE VIEW

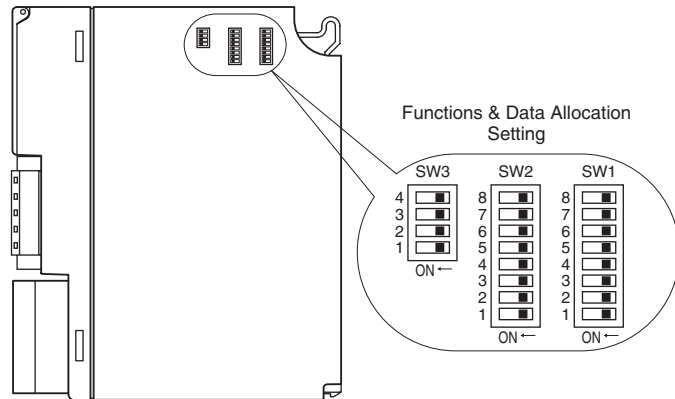

COMMUNICATION CABLE CONNECTIONS

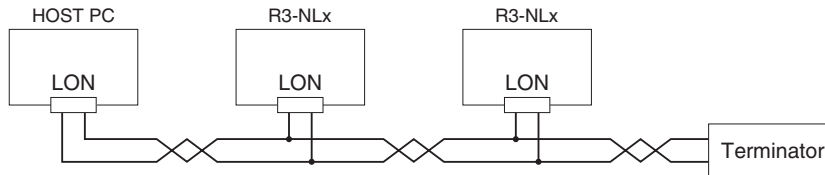

TRANSMISSION DATA DESCRIPTIONS

ANALOG INPUT / OUTPUT

The DIP SW located at the side of the module specifies each I/O module's data allocation (occupied data area).

[Example 1]

Seven (7) of 8-point analog input module:

Position	Module Type	Data Area	Network Variable
Module 1	R3-SV8S	8	nvoLV01 through nvoLV08
Module 2	R3-SV8S	8	nvoLV09 through nvoLV16
Module 3	R3-SV8S	8	nvoLV17 through nvoLV24
Module 4	R3-SV8S	8	nvoLV25 through nvoLV32
Module 5	R3-SV8S	8	nvoLV33 through nvoLV40
Module 6	R3-SV8S	8	nvoLV41 through nvoLV48
Module 7	R3-SV8S	8	nvoLV49 through nvoLV56
Module 8	R3-NL2-N		
Module 9	R3-PS3-R		

The same principle is applied to Analog Output (R3NL2-LVO56) or Temperature Input (R3NL2_T56, R3NL2_TP56).



■ DISCRETE INPUT / OUTPUT

One (1) data area can handle 16 points of discrete signals.

[Example 2]

Four (4) of 16-point discrete input module:

Position	Module Type	Data Area	Network Variable
Module 1	R3-DA16S	1	nvoSW01 through nvoSW16
Module 2	R3-DA16S	1	nvoSW17 through nvoSW32
Module 3	R3-DA16S	1	nvoSW33 through nvoSW48
Module 4	R3-DA16S	1	nvoSW49 through nvoSW56
Module 5	R3-NL2-N		
Module 6	R3-PS1-R		

Channels 9 through 16 of the Module 4 are not transmitted.

■ MIXED I/O

Network Variables for the input channels are assigned first, and then those for the output channels are assigned to the next module position.

[Example 3]

Four (4) of 8-point analog input module and three (3) of 8-point analog output:

Position	Module Type	Data Area	Network Variable
Module 1	R3-SV8S	8	nvoLV01 through nvoLV08
Module 2	R3-SV8S	8	nvoLV09 through nvoLV16
Module 3	R3-SV8S	8	nvoLV17 through nvoLV24
Module 4	R3-SV8S	8	nvoLV25 through nvoLV32
Module 5	R3-YV8S	8	nviLV01 through nviLV08
Module 6	R3-YV8S	8	nviLV09 through nviLV16
Module 7	R3-YV8S	8	nviLV17 through nviLV24
Module 8	R3-NL2-N		
Module 9	R3-PS3-R		

■ TOTALIZED PULSE INPUT / DISCRETE I/O

Network Variables for the discrete input channels are assigned first, and then those for the totalized pulse input channels are assigned to the next module position. Finally those for the discrete output channels are assigned to the following module position. The I/O modules must be assigned as in the following example. Adequate operation is not guaranteed in any other configuration.

[Example 4]

One (1) of 16-point totalized pulse input module, one (1) of 16-point discrete input module, and one (1) of 16-point discrete output:

Position	Module Type	Data Area	Network Variable
Module 1	R3-DA16S	1	nvoSW01 through nvoSW16
Module 2	R3-PA16S	16	nvoC01 through nvoC16
Module 3	R3-DC16S	1	nviSW01 through nviSW16
Module 4	R3-NL2-N		
Module 5	R3-PS1-R		



I/O COMBINATIONS

A dedicated Device File for each I/O device depending upon I/O combinations is required for the setting up using an integration tool such as Lon Maker.

On-line download is available for Device Image files at M-System's homepage.

Functional Blocks usable for respective files are not identical to all. Refer to the table below.

■ANALOG INPUT / OUTPUT

NO. of DATA		NETWORK VARIABLE	DEVICE IMAGE	USABLE FUNCTIONAL BLOCKS
INPUT	OUTPUT			
56	0	SNVT_lev_percent	R3NL2_LVI56_103.XIF R3NL2_LVI56_103.APB	NodeObject NL2LVIn
0	56	SNVT_lev_percent	R3NL2_LVO56_103.XIF R3NL2_LVO56_103.APB	NodeObject NL2LVOOut
32	24	SNVT_lev_percent	R3NL2_LVI32O24_104.XIF R3NL2_LVI32O24_104.APB	NodeObject NL2LVIO

■TEMPERATURE INPUT (°C)

NO. of DATA		NETWORK VARIABLE	DEVICE IMAGE	USABLE FUNCTIONAL BLOCKS
INPUT	OUTPUT			
56	0	SNVT_temp	R3NL2_TI56_103.XIF R3NL2_TI56_103.APB	NodeObject NL2TIIn
56	0	SNVT_temp_p	R3NL2_TPI56_103.XIF R3NL2_TPI56_103.APB	NodeObject NL2TPIIn

■DISCRETE INPUT / OUTPUT

NO. of DATA		NETWORK VARIABLE	DEVICE IMAGE	USABLE FUNCTIONAL BLOCKS
INPUT	OUTPUT			
56	0	SNVT_switch	R3NL2_SWI56_103.XIF R3NL2_SWI56_103.APB	NodeObject NL2SWIn
0	56	SNVT_switch	R3NL2_SWO56_103.XIF R3NL2_SWO56_103.APB	NodeObject NL2SWOut
32	24	SNVT_switch	R3NL2_SWI32O24_103.XIF R3NL2_SWI32O24_103.APB	NodeObject NL2SWIO

■TOTALIZED PULSE INPUT / OUTPUT

NO. of DATA		NETWORK VARIABLE	DEVICE IMAGE	USABLE FUNCTIONAL BLOCKS
INPUT	OUTPUT			
56	0	SNVT_count	R3NL2_CI56_103.XIF R3NL2_CI56_103.APB	NodeObject NL2CIn
0	56	SNVT_count	R3NL2_CO56_104.XIF R3NL2_CO56_104.APB	NodeObject NL2COut
32	24	SNVT_count	R3NL2_CI32CO24_103.XIF R3NL2_CI32CO24_103.APB	NodeObject NL2CInOut

■TOTALIZED PULSE INPUT / DISCRETE INPUT / DISCRETE OUTPUT

NO. of DATA			NETWORK VARIABLE	DEVICE IMAGE	USABLE FUNCTIONAL BLOCKS
TOTAL. PULSE	DISCRETE				
INPUT	INPUT	OUTPUT			
16	16	16	SNVT_count SNVT_switch	R3NL2_CI16SWI16SWO16_103.XIF R3NL2_CI16SWI16SWO16_103.APB	NodeObject NL2CISWIO

XIF File: Device Interface File (external interface)

APB File: Downloadable Application Image File (program for NeuronChip)



EXTERNAL DIMENSIONS & TERMINAL ASSIGNMENTS unit: mm (inch)

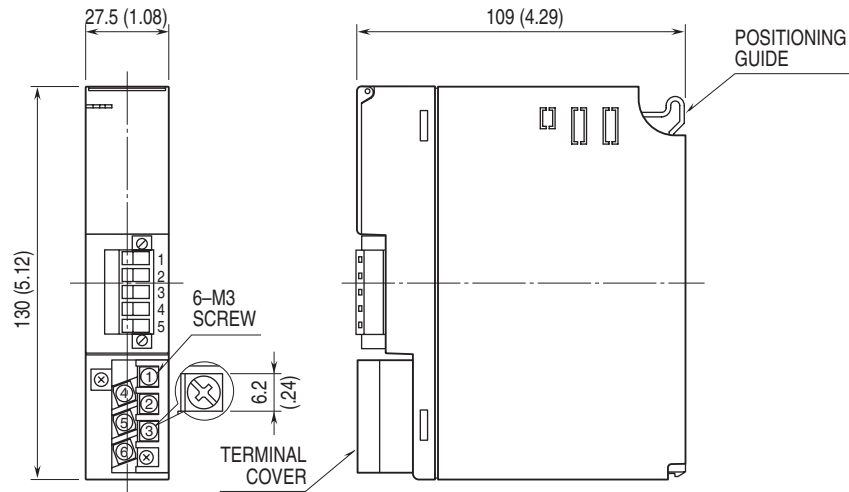

SCHEMATIC CIRCUITRY & CONNECTION DIAGRAM

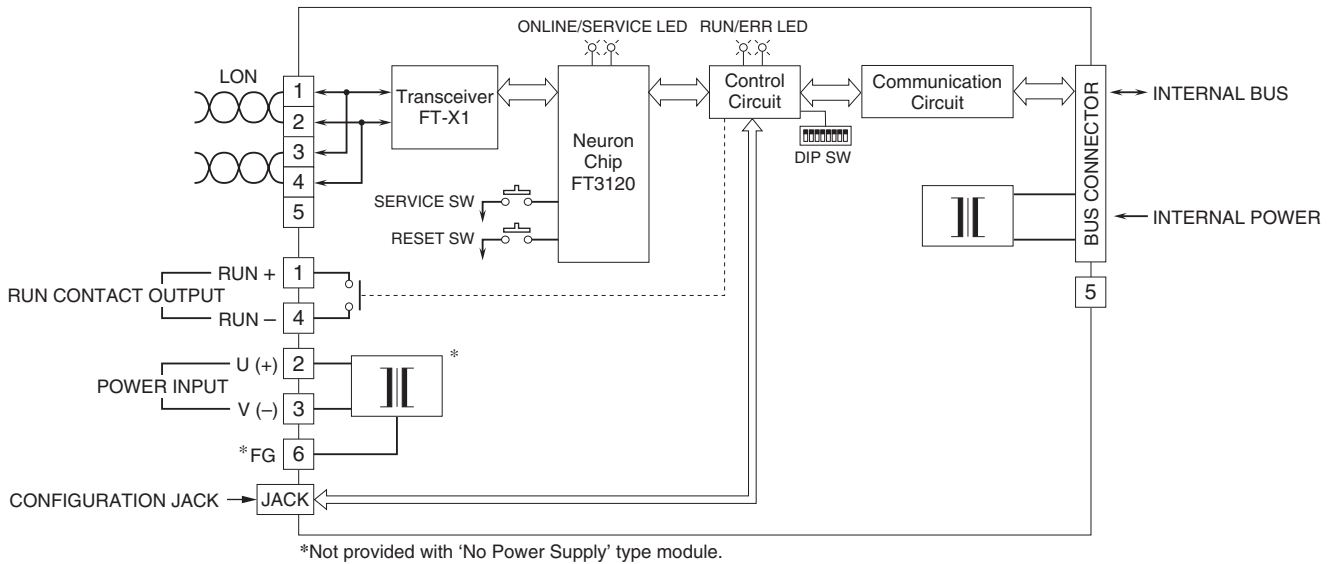

Specifications are subject to change without notice.