

Remote I/O R3 Series

LonWorks INTERFACE MODULE

(analog I/O 16 points, discrete I/O 48 points)

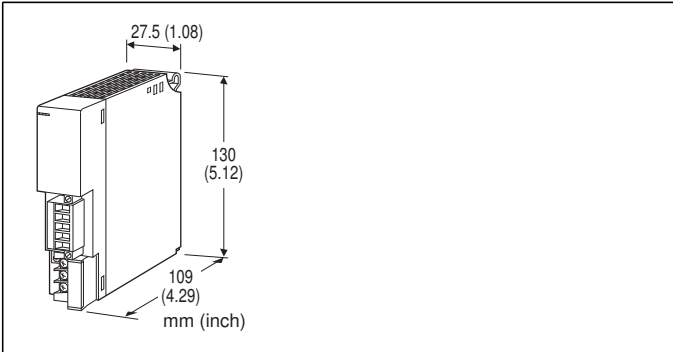

MODEL: R3-NL1-[1][2]

ORDERING INFORMATION

- Code number: R3-NL1-[1][2]
- Specify a code from below for each [1] and [2].
(e.g. R3-NL1-R/Q)
- Specify the specification for option code /Q
(e.g. /C01)

[1] POWER INPUT

N: No power supply

AC Power

K3: 100 - 120 V AC

(Operational voltage range 85 - 132 V, 47 - 66 Hz) *

L3: 200 - 240 V AC

(Operational voltage range 170 - 264 V, 47 - 66 Hz) *

DC Power

R: 24 V DC

(Operational voltage 24 V \pm 10 %, ripple 10 %p-p max.) *

* Not selectable for use with independent power modules.
Not selectable for dual network.

[2] OPTIONS

blank: none

/Q: With options (specify the specification)

SPECIFICATIONS OF OPTION: Q

COATING (For the detail, refer to M-System's web site.)

/C01: Silicone coating

/C02: Polyurethane coating

/C03: Rubber coating

RELATED PRODUCTS

- XIF File (Device Interface File)
- XIF file is used to define a LonWorks device when programmed on LonMaker.

GENERAL SPECIFICATIONS

Connection

Network: Euro type connector terminal

Internal bus: Via the Installation Base
(model: R3-BSx)

Internal power: Via the Installation Base (model: R3-BSx)

Power input, RUN contact output: M3 separable screw terminal (torque 0.5 N·m)

Screw terminal: Nickel-plated steel

Isolation: LonWorks to internal bus or internal power to power input to RUN contact output to FG

Input error data: Input value setting at input module error with side DIP SW

Main/Sub setting: Set with the side DIP switch

Slot assignment: Set with the side DIP switch

RUN indicator: Bi-color (green/red) LED; green in communications with another device online or changing the output data (turns off after 25 seconds of no communication); red when receiving.
(function selected with DIP SW)

ERR indicator: Bi-color (green/red) LED; the green ON/blinks in communication errors; red when transmitting.
(function selected with DIP SW)

RUN contact: Turns on while the green RUN LED is ON
(LonWorks in normal communication)

■ RUN CONTACT OUTPUT

Rated load: 250 V AC @ 0.5 A (cos ϕ = 1)

30 V DC @ 0.5 A (resistive load)

Maximum switching voltage: 250 V AC or 30 V DC

Maximum switching power: 250 VA or 150 W

Minimum load: 1 V DC @ 1 mA

Mechanical life: 2×10^7 cycles (rate 300 cycles/min.) When driving an inductive load, external contact protection and noise quenching recommended.

LonWorks COMMUNICATION

Neuron Chip: FT3120 (NeuronID printed in numbers and bar code [peel-off code 39 format])

Transceiver: FT-X1 (equivalent to FTT10A)

Transmission speed: 78 kbps

Twisted-pair cable

Distance, free topology: 500 meters

Max. 64 nodes/channel

LNS: Ver. 3.0 Service Pack 8 or higher

Network variable type

Analog: SNVT_lev_percent or SNVT_temp (selectable)



Discrete: SNVT_switch

ONLINE indicator: Red LED

ON: Off-line or no network information (decommissioned)

Blinking in approx. 0.5 Hz: On-line

(ready to communicate network variables)

Blinking in approx. 5 Hz for 30 sec: Wink message received

SERVICE indicator: Green LED

OFF: Normal operations

Blinking in approx. 0.5 Hz: No network information

ON: Internal program error

SERVICE switch: Used to identify the node in LonWorks network configuration

RESET switch: Resetting the Neuron Chip

Numbers of data (*factory setting)

Analog Input	Analog Output
16	0
12	4
8 (*)	8 (*)
4	12
0	16
Discrete Input	Discrete Output
0	48
48	0

INSTALLATION

Power consumption

•AC: Approx. 20 VA

•DC: Approx. 12 W

Current consumption (no power supply): 100 mA

Output current (power supply): 250 mA continuous at 20 V DC; 400 mA for 10 minutes

Operating temperature: -10 to +55°C (14 to 131°F)

Operating humidity: 30 to 90 %RH (non-condensing)

Atmosphere: No corrosive gas or heavy dust

Mounting: Installation Base (model: R3-BSx)

Weight: 200 g (0.44 lb)

PERFORMANCE

Insulation resistance: $\geq 100 \text{ M}\Omega$ with 500 V DC

Dielectric strength: 1500 V AC @ 1 minute (LonWorks or internal bus or internal power to power input to RUN contact output to FG)



EXTERNAL VIEW

FRONT VIEW

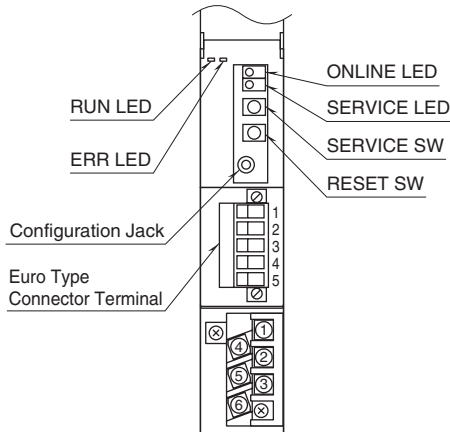

SIDE VIEW

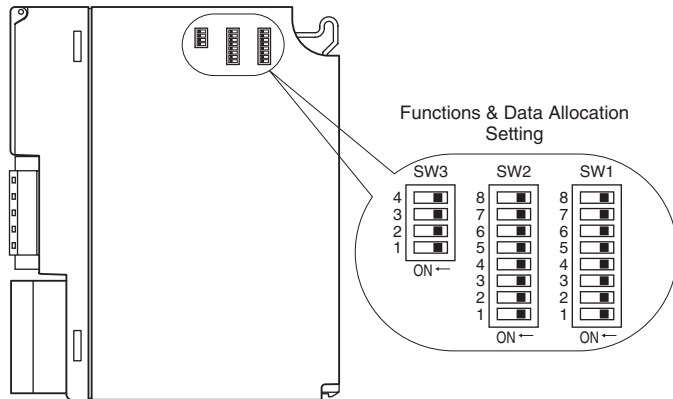

COMMUNICATION CABLE CONNECTIONS

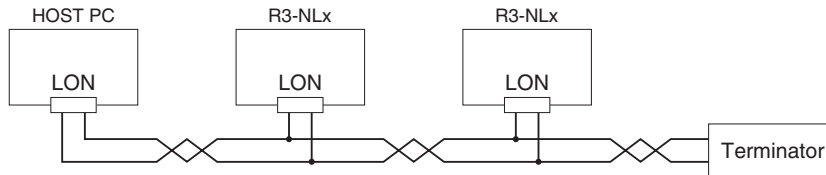

TRANSMISSION DATA DESCRIPTIONS

The DIP SW located at the side of the module specifies each I/O module's data allocation (occupied data area).

Data are assigned in turn from Slot 1, in order of Functional Blocks (Input or GetValue/R3Di first, followed by Output or SetValue/R3Do).

The 1st output must be the 1st transmitted data in the slot next to the one with the last input data.

[Example 1]

Module	Data Area	Functional Block
Module 1	4	GetValue [0 – 3]
Module 2	4	GetValue [4 – 7]
Module 3	4	SetValue [0]
Module 4	1	SetValue [1]
Module 5	1	SetValue [2]
Module 6	1	SetValue [3]
Module 7	1	SetValue [4]
Module 8	1	SetValue [5]
Module 9	1	SetValue [6]
Module 10	1	SetValue [7]

[Example 2]

Module	Data Area	Functional Block	Notes
Module 1	1	GetValue [0]	
Module 2	4	GetValue [1 – 4]	
Module 3	4	GetValue [5 – 7]	The 4th data, Slot 3 is invalid.
Module 4	1	SetValue [0]	
Module 5	4	SetValue [1 – 4]	
Module 6	4	SetValue [5 – 7]	The 4th data, Slot 6 is invalid.

When the data consist of only inputs or outputs, data for the total of 16 Functional Blocks (GetValue [0 – 15] or R3Di [0 – 2], or SetValue [0 – 15] or R3Do [0 – 2]) are assigned to each module position from Slot 1.



I/O COMBINATIONS

A dedicated Device File for each I/O device depending upon I/O combinations is required using an integration tool such as Lon Maker.

On-line download is available for Device Image files at M-System's homepage.

Functional Blocks usable for respective files are not identical to all. Refer to the manual.

■ANALOG INPUT / OUTPUT

NO. of DATA		DEVICE IMAGE (APB FILE)	USABLE FUNCTIONAL BLOCKS
INPUT	OUTPUT		
16	0	R3NL1_1_101.APB	NodeObjet, GetValue [0 ... 15] (Can be defined from 0 to 15)
12	4	R3NL1_2_101.APB	NodeObjet, GetValue [0 ... 11], SetValue [0 ... 3]
8	8	R3NL1_3_101.APB	NodeObjet, GetValue [0 ... 7], SetValue [0 ... 7]
4	12	R3NL1_4_101.APB	NodeObjet, GetValue [0 ... 3], SetValue [0 ... 11]
0	16	R3NL1_5_101.APB	NodeObjet, SetValue [0 ... 15]

■DISCRETE INPUT / OUTPUT

NO. of DATA		DEVICE IMAGE (APB FILE)	USABLE FUNCTIONAL BLOCKS
INPUT	OUTPUT		
0	48	R3NL1_6_101.APB	NodeObjet, R3Do [0 ... 2] (One (1) block can handle 16 contacts.)
48	0	R3NL1_7_101.APB	NodeObjet, R3Di [0 ... 2]

EXTERNAL DIMENSIONS & TERMINAL ASSIGNMENTS unit: mm (inch)

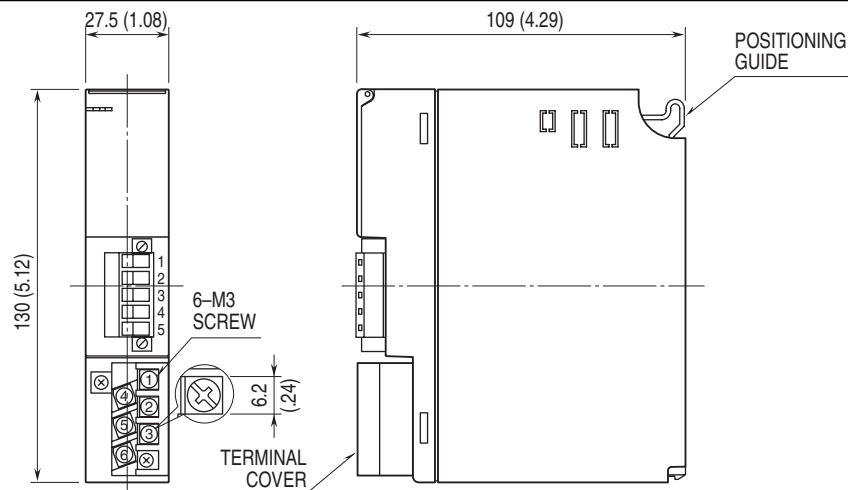

SCHEMATIC CIRCUITRY & CONNECTION DIAGRAM

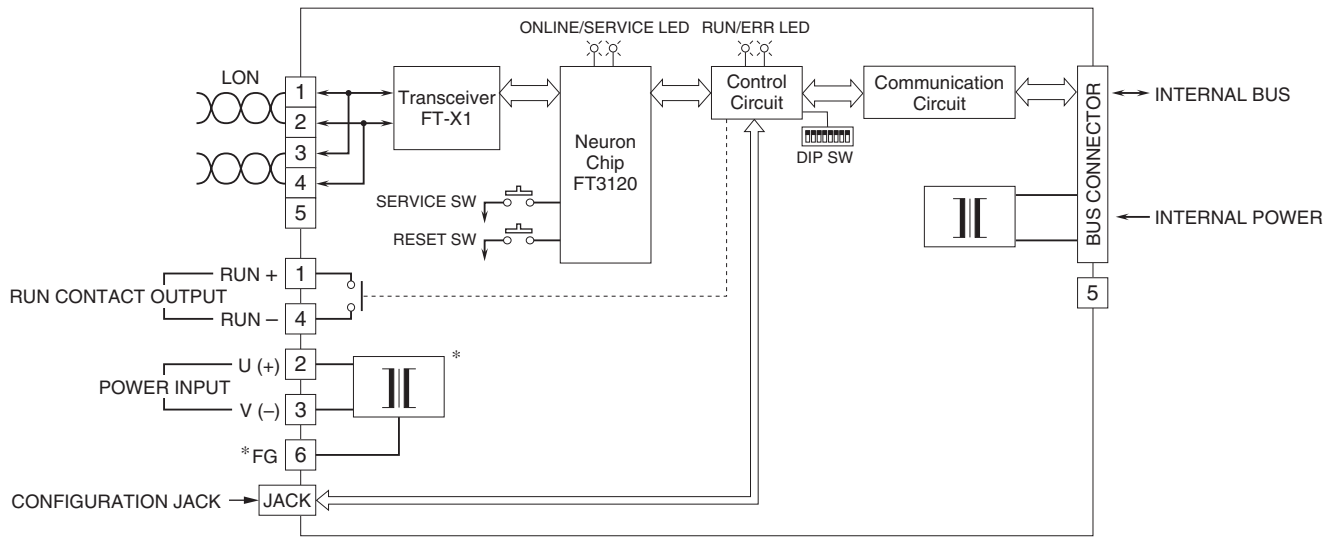

*Not provided with 'No Power Supply' type module.



Specifications are subject to change without notice.

