

Remote I/O R3 Series

EtherNet/IP INTERFACE MODULE

Functions & Features

- Converts analog and discrete I/O data to the open network fieldbus (EtherNet/IP)

Typical Applications

- Remote I/O for DCS and PLC

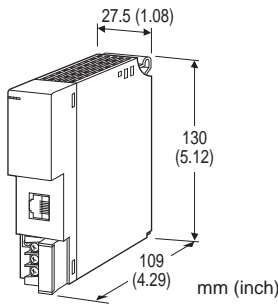

EtherNet/IP™
conformance tested

MODEL:R3-NEIP1[1]

ORDERING INFORMATION

- Code number: R3-NEIP1[1]

Specify a code from below for [1].

(e.g. R3-NEIP1/Q)

- Specify the specification for option code /Q (e.g. /C01)

[1] OPTIONS

blank: none

/Q: With options (specify the specification)

SPECIFICATIONS OF OPTION: Q

COATING (For the detail, refer to M-System's web site.)

/C01: Silicone coating

/C02: Polyurethane coating

/C03: Rubber coating

RELATED PRODUCTS

- PC configurator software (model: R3CON)
- EDS file

The EDS file and configurator software are downloadable at M-System's web site.

A dedicated cable is required to connect the module to the PC. Please refer to the internet software download site or the users manual for the PC configurator for applicable cable types.

GENERAL SPECIFICATIONS

Connection

Network: RJ-45 Modular Jack

Internal bus: Via the Installation Base (model: R3-BSx)

Internal power: Via the Installation Base (model: R3-BSx)

RUN contact output: M3 separable screw terminal (torque 0.5 N·m)

Screw terminal: Nickel-plated steel

Isolation: EtherNet/IP to internal bus or internal power to RUN contact output

Input error data: Input value setting at input module error with side DIP SW

Main/Sub setting: Set with the side DIP switch

Slot assignment: Set with the side DIP switch

RUN contact: Turns ON when both MS and NS LEDs are green (EtherNet/IP in normal communication).

■ RUN CONTACT OUTPUT

Rated load: 250 V AC @ 0.5 A ($\cos \phi = 1$)

30 V DC @ 0.5 A (resistive load)

Maximum switching voltage: 250 V AC or 30 V DC

Maximum switching power: 250 VA or 150 W

Minimum load: 1 V DC @ 1 mA

Mechanical life: 2×10^7 cycles (rate 300 cycles/min.) When driving an inductive load, external contact protection and noise quenching recommended.

EtherNet/IP COMMUNICATION

Communication Standard: IEEE 802.3u

Transmission: 10BASE-T, 100BASE-TX

Baud rate: 10/100 Mbps (Auto Negotiation function)

Max. number of socket connections: 3

Connection type: Exclusive owner, Listen only, Input only

Protocol: EtherNet/IP

Transmission media: 10BASE-T (STP, Category 5)

100BASE-TX (STP, Category 5e)

Max. length of fieldbus segment: 100 meters

IP address: 192.168.0.1 (factory setting); Selectable with PC Configurator Software (model: R3CON)

BOOTP and DHCP available

Port No.: 44818

I/O data area size: Input and output data area size set with side DIP SW

Required data words:

Input: 35, 67, 131, 252 words

Output: 35, 67, 131, 252 words (3 words are used only for status)

Ethernet indicator LED: TX/RX, LINK

MS (Module Status) indicator: Bi-color (green/red) LED indicates device status.

NS (Network Status) indicator: Bi-color (green/red) LED indicates status of the communication link.

Note: Not connectable beyond router.



幸託有限公司
XIN TOP CORPORATION

TEL : (02)2598-1199

FAX : (02)2596-2331

E-mail : info@xintop.com

Website : www.xintop.com

INSTALLATION

Operating temperature: -10 to +55°C (14 to 131°F)
Operating humidity: 30 to 90 %RH (non-condensing)
Atmosphere: No corrosive gas or heavy dust
Mounting: Installation Base (model: R3-BSx)
Weight: 200 g (0.44 lb)

PERFORMANCE

Current consumption: 130 mA
Insulation resistance: $\geq 100 \text{ M}\Omega$ with 500 V DC
Dielectric strength: 1500 V AC @ 1 minute
(EtherNet/IP to internal bus or internal power to RUN contact output)
2000 V AC @ 1 minute (power input to FG; isolated on the power supply module)

EXTERNAL VIEW

FRONT VIEW

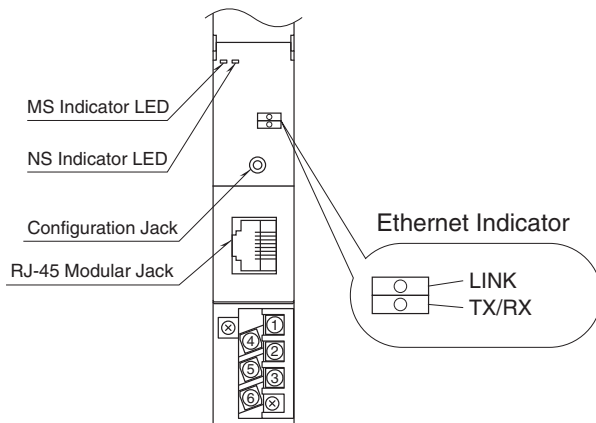

SIDE VIEW

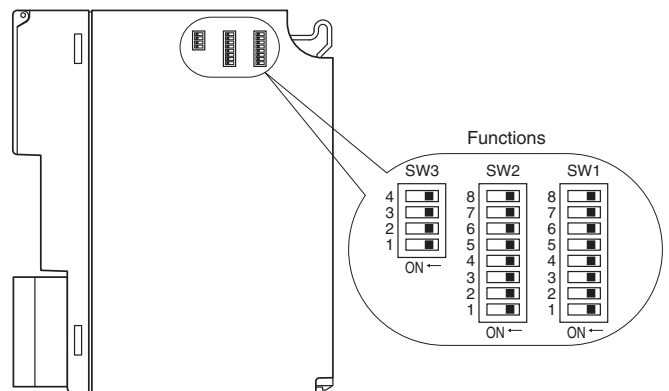

TRANSMISSION DATA DESCRIPTIONS

The DIP SW located at the side of the module specifies each I/O module's data allocation (occupied data area and size of the I/O data area). For example, when the data areas are assigned as shown below:

Module 1	4
Module 2	4
Module 3	4
Module 4	1
Module 5	1
Module 6	1
Module 7	1

I/O data area: 252 words each for input and output.

Then the I/O data are assigned as in the figures below:

■ OUTPUT DATA

The figure below shows the allocation of the data sent from the network module to the master.

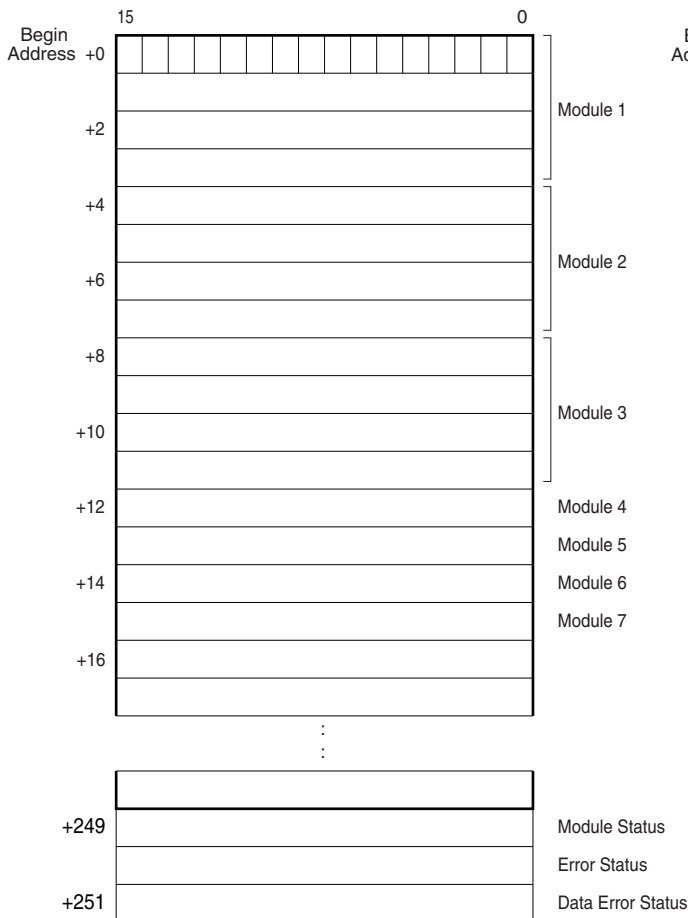

■ INPUT DATA

The figure below shows the allocation of the data sent from the master to the network module.

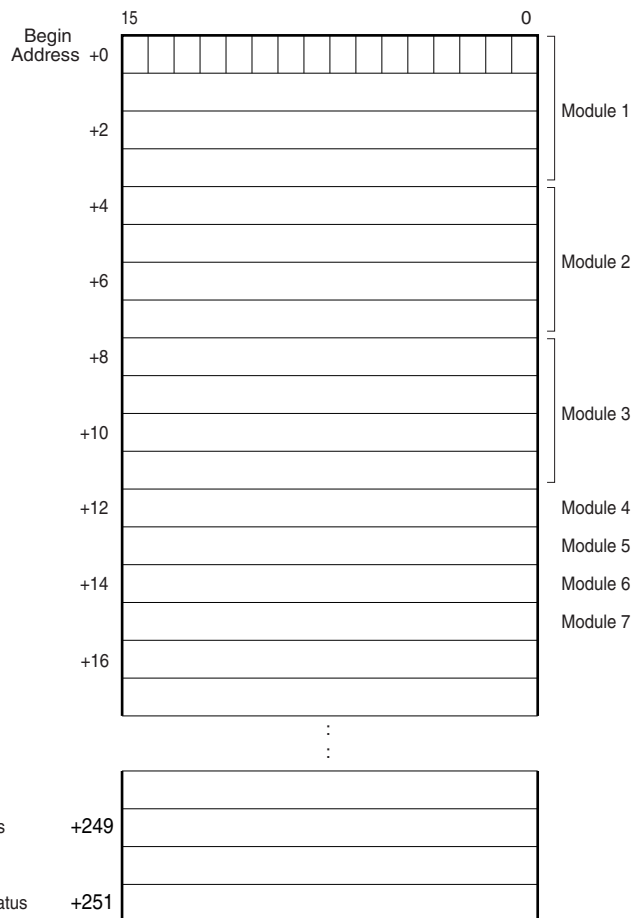

The area enclosed with bold line is assigned for I/O data

Module Status, Error Status and Data Error Status are assigned to the last three words of the output data respectively. Each module can handle either input or output data.

- Module Status indicates whether individual I/O module are mounted or not. The bit corresponding to the mounted slots turns to "1," and the unmounted slots to "0."
- Error Status indicates error status for each module as described below. The bit corresponding to such modules turns to "1."
 R3-TSx, R3-RSx, R3-US4 (T/C or RTD input): Input burnout
 R3-DA16A: Power input in error or disconnected
 R3-YSx: Output current error (e.g. load unconnected)
- Data Error Status indicates overrange (R3-US4: out of -10% to +110%; the other types: out of -15% to +115%) status for each module. The bit corresponding to such modules turns to "1."



I/O DATA DESCRIPTIONS

■ MODULE STATUS, ERROR STATUS, DATA ERROR STATUS

Shows each module's availability and error status.

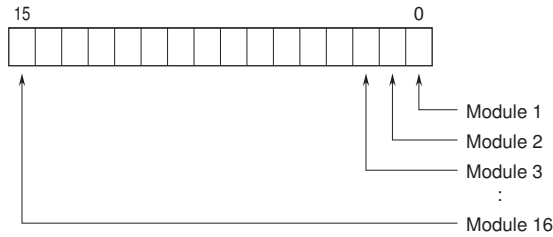

■ ANALOG DATA (models: R3-SV4, YV4, DS4, YS4, US4, etc.)

16-bit binary data.

Basically, 0 to 100% of the selected I/O range is converted into 0 to 10000 (binary). Negative percentage is represented in 2's complements.



■ TEMPERATURE DATA (models: R3-RS4, TS4, US4, etc.)

16-bit binary data.

With °C temperature unit, raw data is multiplied by 10. For example, 25.5°C is converted into 255.

With °F temperature unit, the integer section of raw data is directly converted into the data.

For example, 135.4°F is converted into 135.

Minus temperature is converted into negative values, represented in 2's complements.



■ ACCUMULATED COUNT DATA (32-bit data, models: R3-PA2, PA4A, WT1, WT4, etc.)

32-bit binary data is used for accumulated counts and encoder positions.

Lower 16 bits are allocated from the lowest address to higher ones, higher 16 bits in turn.

32-bit data cannot be accessed using floating addresses.



■ BCD DATA (32-bit data, models: R3-BA32A, BC32A, etc.)

32-bit binary data is used for BCD.

Lower 16 bits are allocated from the lowest address to higher ones, higher 16 bits in turn.

32-bit data cannot be accessed using floating addresses.

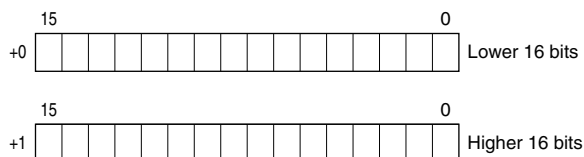

■ 16-POINT DISCRETE DATA (models: R3-DA16, DC16, etc.)

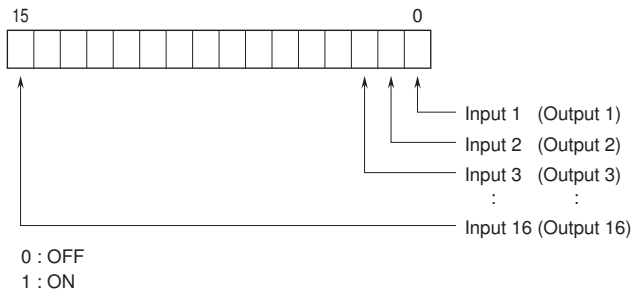

EXTERNAL DIMENSIONS & TERMINAL ASSIGNMENTS unit: mm (inch)

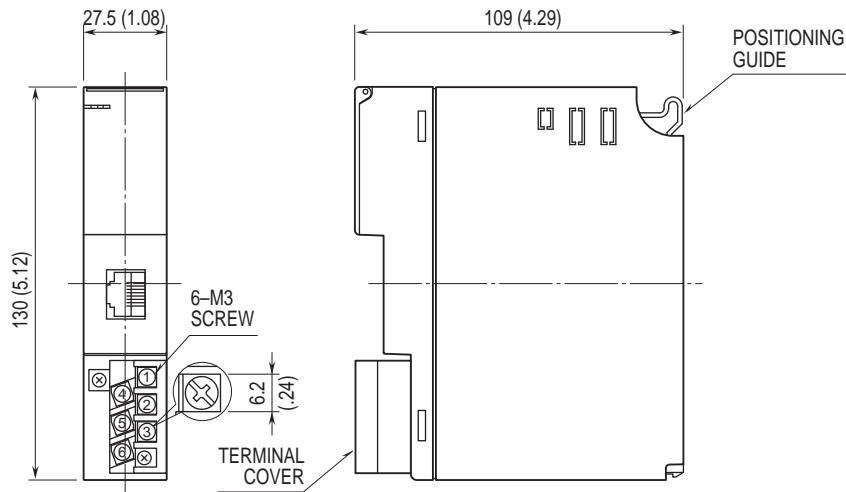

SCHEMATIC CIRCUITRY & CONNECTION DIAGRAM

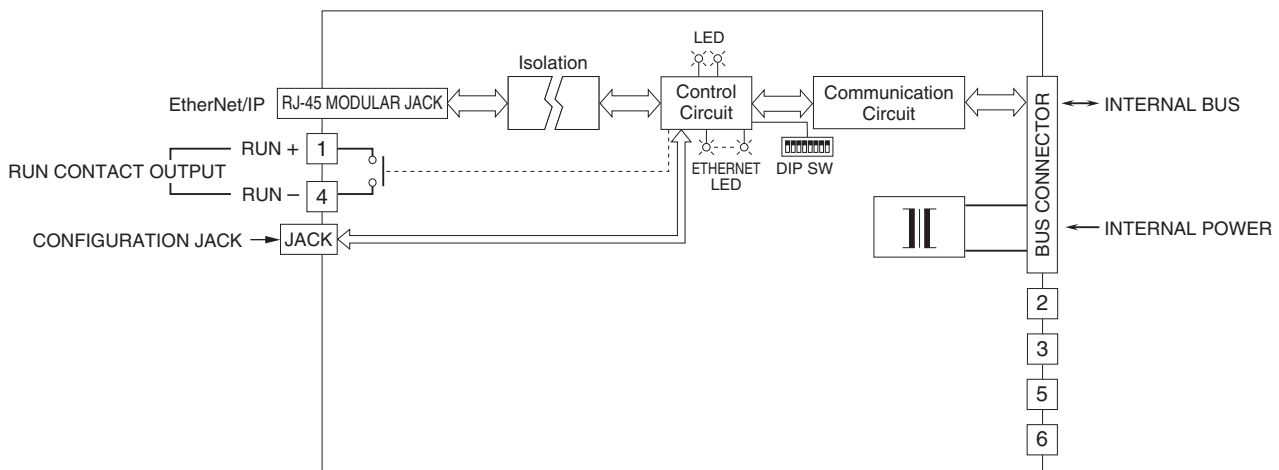

SYSTEM CONFIGURATION EXAMPLES

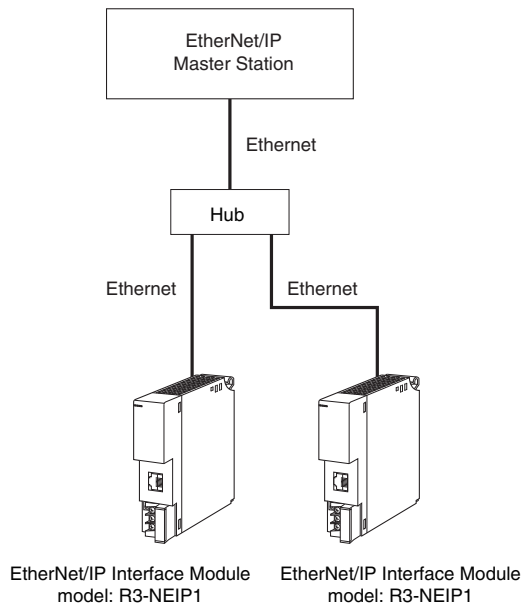

Specifications are subject to change without notice.

