

## Remote I/O R3 Series

### DeviceNet INTERFACE MODULE

(for 16-point analog signals)

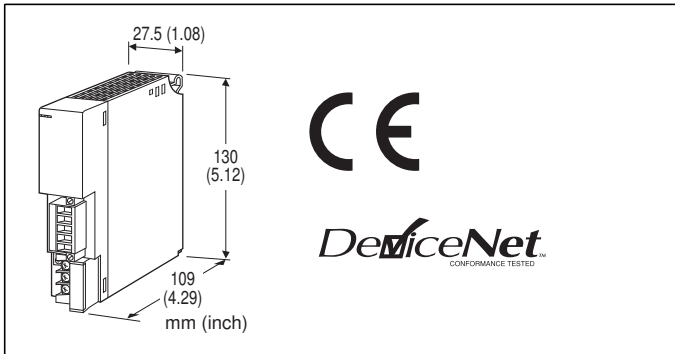

### MODEL: R3-ND1-[1][2]

#### ORDERING INFORMATION

- Code number: R3-ND1-[1][2]
- Specify a code from below for each [1] and [2].  
(e.g. R3-ND1-R/CE/Q)
- Specify the specification for option code /Q  
(e.g. /C01)

#### [1] POWER INPUT

**N:** No power supply

##### AC Power

**K3:** 100 - 120 V AC

(Operational voltage range 85 - 132 V, 47 - 66 Hz) \*  
(CE not available)

**L3:** 200 - 240 V AC

(Operational voltage range 170 - 264 V, 47 - 66 Hz) \*  
(CE not available)

##### DC Power

**R:** 24 V DC

(Operational voltage 24 V  $\pm$ 10 %, ripple 10 %p-p max.) \*  
\* Not selectable for use with independent power modules.

Not selectable for dual network.

#### [2] OPTIONS (multiple selections)

##### Standards & Approvals

**blank:** Without CE

**/CE:** CE marking

##### Other Options

**blank:** none

**/Q:** Option other than the above (specify the specification)

#### SPECIFICATIONS OF OPTION: Q

**COATING** (For the detail, refer to M-System's web site.)

**/C01:** Silicone coating

**/C02:** Polyurethane coating

**/C03:** Rubber coating

#### RELATED PRODUCTS

- EDS file  
(downloadable at M-System's web site.)

#### GENERAL SPECIFICATIONS

##### Connection

**Network:** Euro type connector terminal

**Internal bus:** Via the Installation Base  
(model: R3-BSx)

**Internal power:** Via the Installation Base (model: R3-BSx)

**Power input, RUN contact output:** M3 separable screw terminal (torque 0.5 N·m)

**Screw terminal:** Nickel-plated steel

**Isolation:** DeviceNet to internal bus or internal power to power input to RUN contact output to FG

**Input error data:** Input value setting at input module error with side DIP SW

**Main/Sub setting:** Set with the side DIP switch

**Slot assignment:** Set with the side DIP switch

**RUN contact:** Turns ON when both MS and NS LEDs are green (DeviceNet in normal communication).

##### ■ RUN CONTACT OUTPUT

**Rated load:** 250 V AC @ 0.5 A ( $\cos \phi = 1$ )

30 V DC @ 0.5 A (resistive load)

(Max. 50 V AC to conform with EC Directive)

**Maximum switching voltage:** 250 V AC or 30 V DC

**Maximum switching power:** 250 VA or 150 W

**Minimum load:** 1 V DC @ 1 mA

**Mechanical life:**  $2 \times 10^7$  cycles (300 cycles/min.)

When driving an inductive load, external contact protection and noise quenching recommended.

#### DeviceNet COMMUNICATION

**Transmission cable:** Approved for DeviceNet

**Node address setting:** DIP switch; 00 - 63

**Baud rate:** 125 kbps, 250 kbps, 500 kbps DIP switch

**NS (Network Status) indicator:** Bi-color (green/red) LED indicates status of the communication link.

**MS (Module Status) indicator:** Bi-color (green/red) LED indicates device status.

**Data allocation:** 16 words for input data 19 words for output data



## INSTALLATION

### Power consumption

- AC: Approx. 20 VA
- DC: Approx. 12 W

**Current consumption (no power supply):** 80 mA

**Output current (power supply):** 270 mA continuous at 20 V DC; 420 mA for 10 minutes

**Supply voltage to network:** 11 - 25 V DC supplied through the network terminal block

**Supply current to network:** 50 mA max.

**Operating temperature:** -10 to +55°C (14 to 131°F)

**Operating humidity:** 30 to 90 %RH (non-condensing)

**Atmosphere:** No corrosive gas or heavy dust

**Mounting:** Installation Base (model: R3-BSx)

**Weight:** 200 g (0.44 lb)

## PERFORMANCE

**Insulation resistance:**  $\geq 100 \text{ M}\Omega$  with 500 V DC

**Dielectric strength:** 1500 V AC @ 1 minute

(DeviceNet to internal bus or internal power to power input to RUN contact output to FG)

## STANDARDS & APPROVALS

### CE conformity:

EMC Directive (2004/108/EC)

EMI EN 61000-6-4: 2007/A1: 2011

EMS EN 61000-6-2: 2005

## EXTERNAL VIEW

### FRONT VIEW

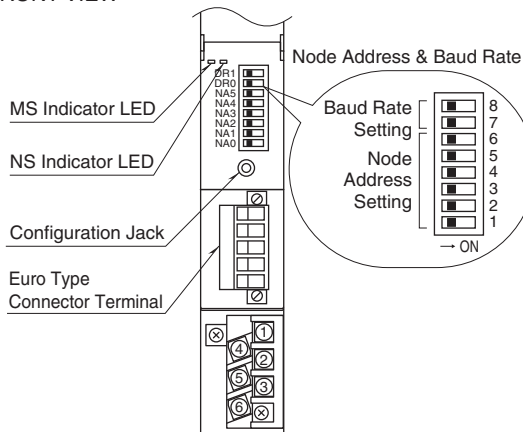

### SIDE VIEW

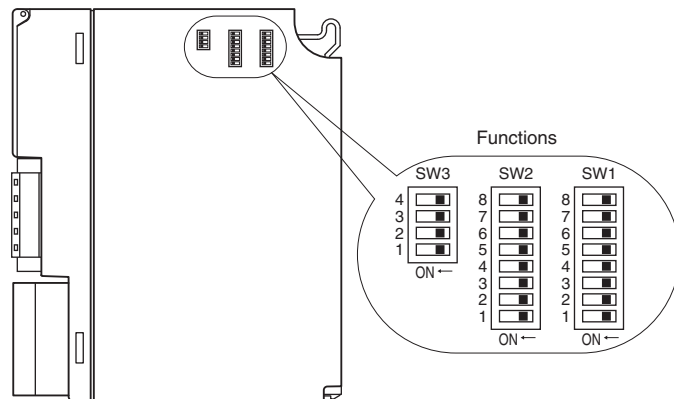

## TRANSMISSION DATA DESCRIPTIONS

The DIP SW located at the side of the module specifies each I/O module's data allocation (occupied data area).  
For example, when the data areas are assigned as shown below:

Module 1	4
Module 2	4
Module 3	4
Module 4	1
Module 5	1
Module 6	1
Module 7	1

Then the I/O data are assigned as in the figures below:

### ■ OUTPUT DATA

The figure below shows the allocation of the data sent from the network module to the master.

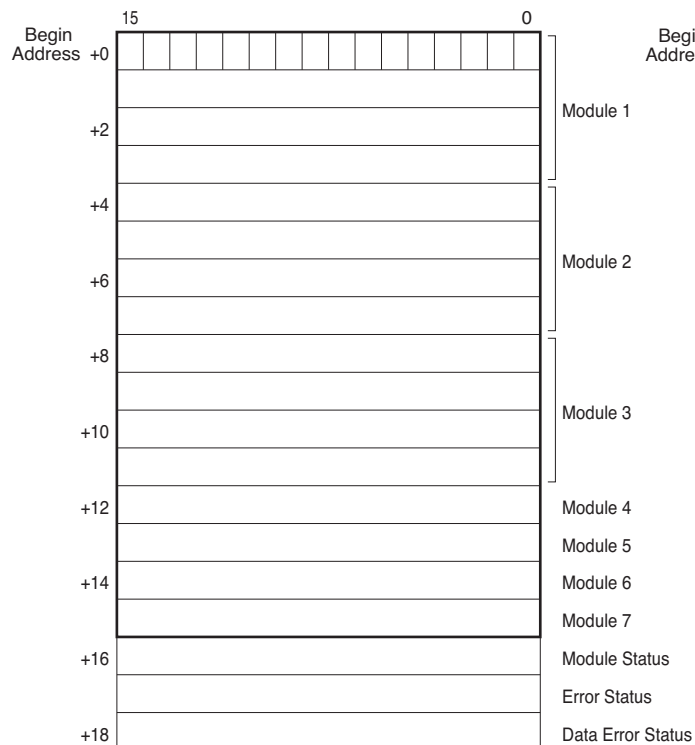

### ■ INPUT DATA

The figure below shows the allocation of the data sent from the master to the network module.

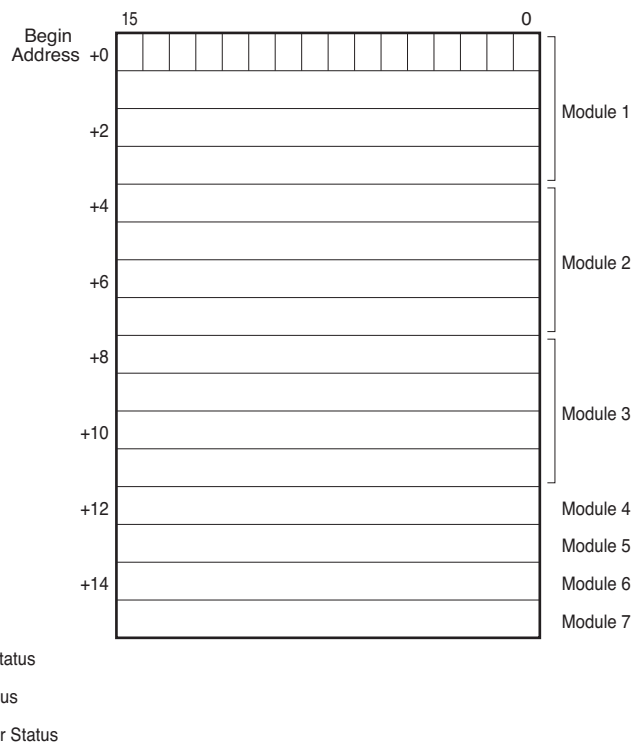

Module Status, Error Status and Data Error Status are assigned to +16, +17 and +18 respectively.

Each module can handle either input or output data. Input and output cannot be mixed in one module.

Input data from the master device is transferred to the module's output data area. The master device can read from the output data area the data it has set.

- Module Status indicates whether individual I/O module are mounted or not. The bit corresponding to the mounted slots turns to "1," and the unmounted slots to "0."

- Error Status indicates error status for each module as described below. The bit corresponding to such modules turns to "1."  
R3-TSx, R3-RSx, R3-US4 (T/C or RTD input): Input burnout  
R3-DA16A: Power input in error or disconnected  
R3-YSx: Output current error (e.g. load unconnected)

- Data Error Status indicates overrange (R3-US4: out of -10% to +110%; the other types: out of -15% to +115%) status for each module. The bit corresponding to such modules turns to "1."



## I/O DATA DESCRIPTIONS

### ■ MODULE STATUS, ERROR STATUS, DATA ERROR STATUS

Shows each module's availability and error status.

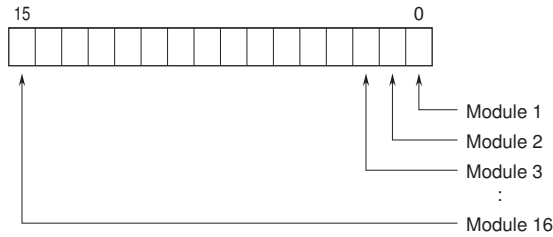

### ■ ANALOG DATA (models: R3-SV4, YV4, DS4, YS4, US4, etc.)

16-bit binary data.

Basically, 0 to 100% of the selected I/O range is converted into 0 to 10000 (binary). Negative percentage is represented in 2's complements.



### ■ TEMPERATURE DATA (models: R3-RS4, TS4, US4, etc.)

16-bit binary data.

With °C temperature unit, raw data is multiplied by 10. For example, 25.5°C is converted into 255.

With °F temperature unit, the integer section of raw data is directly converted into the data.

For example, 135.4°F is converted into 135.

Minus temperature is converted into negative values, represented in 2's complements.



### ■ 16-POINT DISCRETE DATA (models: R3-DA16, DC16, etc.)

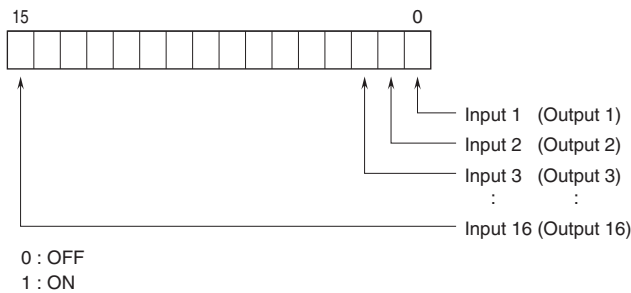

## EXTERNAL DIMENSIONS & TERMINAL ASSIGNMENTS unit: mm (inch)

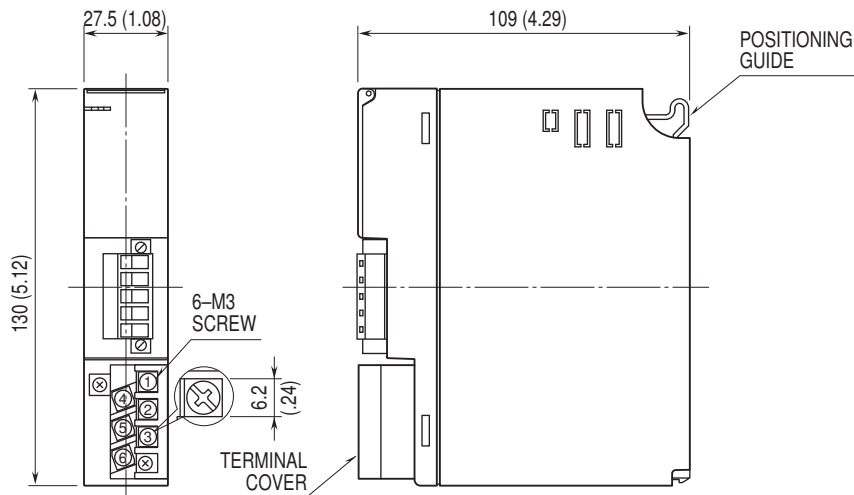

**SCHEMATIC CIRCUITRY & CONNECTION DIAGRAM**

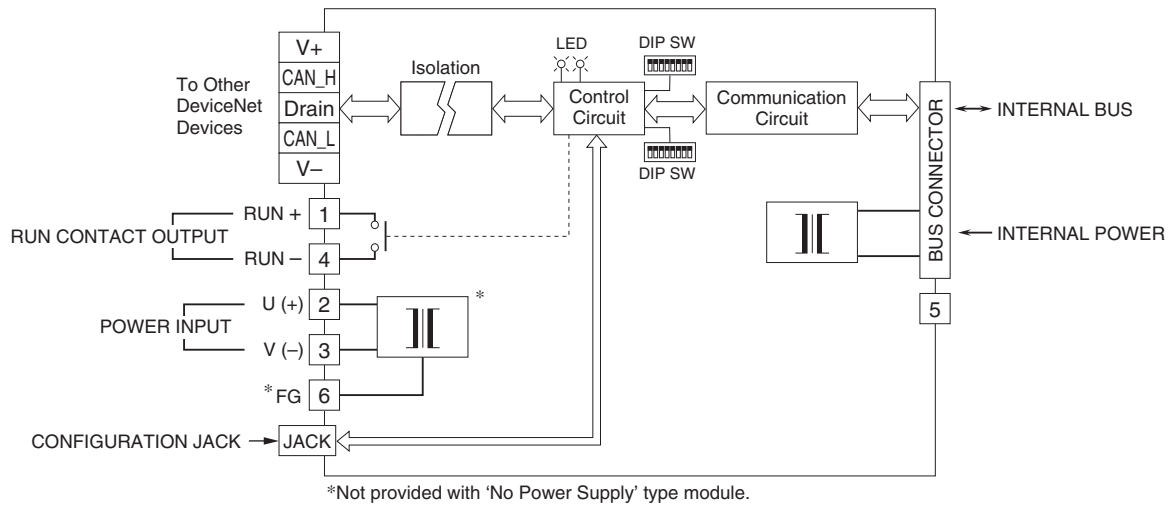

Specifications are subject to change without notice.

