

Remote I/O R3 Series

CC-Link INTERFACE MODULE

(CC-Link Ver.1.10; for 16-point analog signals)

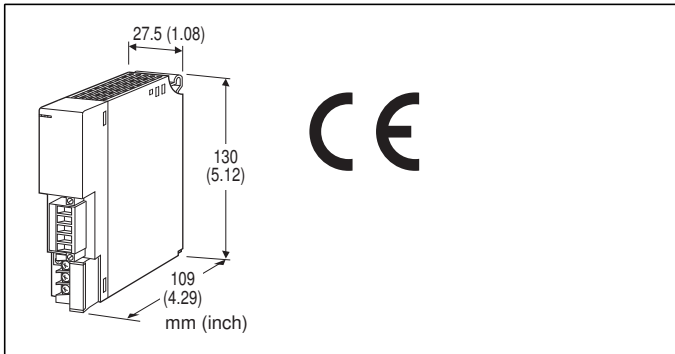

MODEL: R3-NC1-[1][2]

ORDERING INFORMATION

- Code number: R3-NC1-[1][2]
- Specify a code from below for each [1] and [2].
(e.g. R3-NC1-N/CE/W/Q)
- Specify the specification for option code /Q
(e.g. /C01)

[1] POWER INPUT

N: No power supply

AC Power

K3: 100 - 120 V AC

(Operational voltage range 85 - 132 V, 47 - 66 Hz) *
(CE not available)

L3: 200 - 240 V AC

(Operational voltage range 170 - 264 V, 47 - 66 Hz) *
(CE not available)

DC Power

R: 24 V DC

(Operational voltage 24 V \pm 10 %, ripple 10 %p-p max.) *

* Not selectable for use with independent power modules.
Not selectable for dual network.

[2] OPTIONS (multiple selections)

Standards & Approvals

blank: Without CE

/CE: CE marking

Mitsubishi PLC Redundant System

blank: Without

/W: With

Other Options

blank: none

/Q: Option other than the above (specify the specification)

SPECIFICATIONS OF OPTION: Q

COATING (For the detail, refer to M-System's web site.)

/C01: Silicone coating

/C02: Polyurethane coating

/C03: Rubber coating

PACKAGE INCLUDES...

- Terminating resistor (110 Ω , 0.25 W)

GENERAL SPECIFICATIONS

Connection

Network: Euro type connector terminal

Internal bus: Via the Installation Base

(model: R3-BSx)

Internal power: Via the Installation Base (model: R3-BSx)

Power input, RUN contact output: M3 separable screw terminal (torque 0.5 N·m)

Screw terminal: Nickel-plated steel

Isolation: CC-Link to internal bus or internal power to power supply to RUN contact output to FG

Input error data: Input value setting at input module error with side DIP SW

RUN indicator: Bi-color (green/red) LED; Green ON in normal communication; Red ON when receiving (Function selected with DIP SW)

ERR indicator: Bi-color (green/red) LED;

Green ON or blinking in communication error(OFF with cable disconnection, blinking in setting error) Red when transmitting (Function selected with DIP SW)

RUN contact: Turns ON while the green RUN LED is ON (CC-Link in normal communication).

■ RUN CONTACT OUTPUT

Rated load: 250 V AC @ 0.5 A (cos ϕ = 1)

30 V DC @ 0.5 A (resistive load)

(Max. 50 V AC to conform with EC Directive)

Maximum switching voltage: 250 V AC or 30 V DC

Maximum switching power: 250 VA or 150 W

Minimum load: 1 V DC @ 1 mA

Mechanical life: 2×10^7 cycles (300 cycles/min.)

When driving an inductive load, external contact protection and noise quenching recommended.

CC-Link COMMUNICATION

CC-Link: Conforms to Version 1.10

Station No. setting: Rotary switch; 1 - 64

Main/Sub setting: Set with the side DIP switch

Slot assignment: Set with the side DIP switch

Baud rate setting: Rotary switch

156kbps, 625kbps, 2.5Mbps, 5Mbps, 10Mbps

Station type: Remote device station

Data allocation: 4 (128 I/O points, 16 words)



Transmission cable: Approved for CC-Link

INSTALLATION

Power consumption

- AC: Approx. 20 VA
- DC: Approx. 12 W

Current consumption (no power supply): 120 mA

Output current (power supply): 250 mA continuous at 20 V DC; 400 mA for 10 minutes

Operating temperature: -10 to +55°C (14 to 131°F)

Operating humidity: 30 to 90 %RH (non-condensing)

Atmosphere: No corrosive gas or heavy dust

Mounting: Installation Base (model: R3-BSx)

Weight: 200 g (0.44 lb)

PERFORMANCE

Insulation resistance: $\geq 100 \text{ M}\Omega$ with 500 V DC

Dielectric strength: 1500 V AC @ 1 minute (CC-Link to internal bus or internal power to power input to RUN contact output to FG)

STANDARDS & APPROVALS

CE conformity:

EMC Directive (2004/108/EC)

EMI EN 61000-6-4: 2007/A1: 2011

EMS EN 61000-6-2: 2005

EXTERNAL VIEW

FRONT VIEW

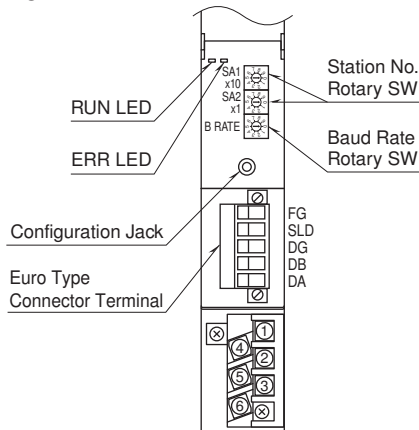

SIDE VIEW

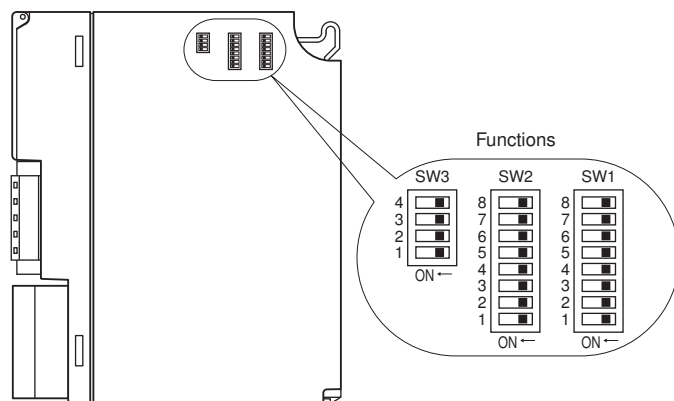

COMMUNICATION CABLE CONNECTIONS

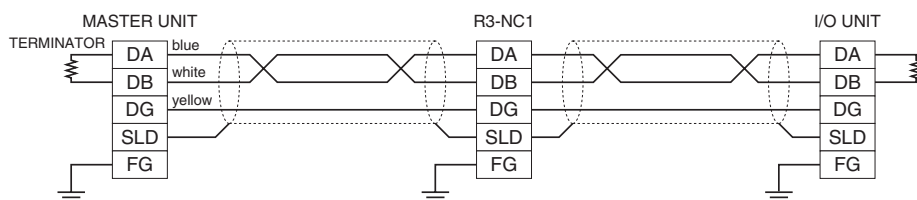

TRANSMISSION DATA DESCRIPTIONS

The DIP SW located at the side of the module specifies each I/O module's data allocation (occupied data area).
 For example, when the data areas are assigned as shown below:

- Module 1 4
- Module 2 4
- Module 3 4
- Module 4 1
- Module 5 1
- Module 6 1
- Module 7 1

Then the I/O data are assigned as in the figures below:

■ OUTPUT DATA

The figure below shows the allocation of the data sent from the network module to the master.

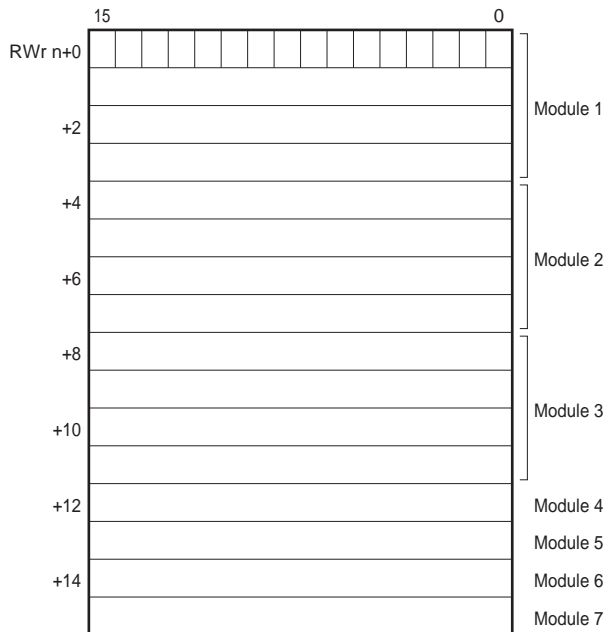

■ INPUT DATA

The figure below shows the allocation of the data sent from the master to the network module.

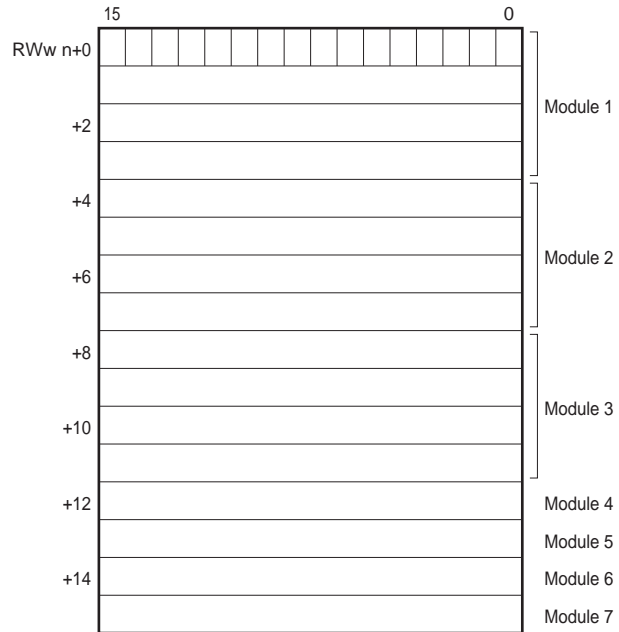

Sixteen (16) data areas are available. Total data areas occupied by I/O modules must be within this limitation.



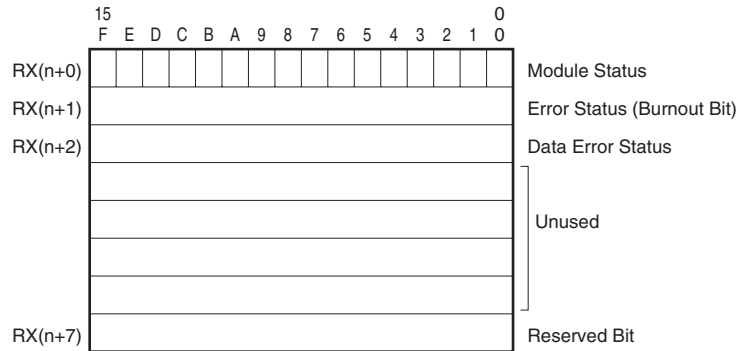

•Module Status

RX(n+0)0 through RX(n+0)F indicate whether individual I/O module are mounted or not. The bit corresponding to the mounted slots turns to "1," and the unmounted slots to "0."

•Error Status

RX(n+1)0 through Rx(n+1)F indicate error status for each module as described below. The bit corresponding to such modules turns to "1."

- TSx, -RSx, -US4: Input burnout
- DA16A: Power input in error or disconnected
- YSx: Output current error (e.g. load unconnected)

•Data Error Status

RX(n+2)0 through Rx(n+2)F indicate overrange (-US4: out of -10% to +110%; the other types: out of -15% to +115%) status for each module. The bit corresponding to such modules turns to "1."

•RX(n+3) through RX(n+6) are unused.

•RX(n+7)0 through RX(n+7)7 are reserved for future use. RX(n+7)B is assigned to Ready signal, which is turned to "1" when the network module is in normal conditions. RX(n+7)8 through RX(n+7)A, RX(n+7)C through RX(n+7)F are not used.

RX(n+0) 0, RX(n+1) 0, RX(n+2) 0	Module 1
RX(n+0) 1, RX(n+1) 1, RX(n+2) 1	Module 2
RX(n+0) 2, RX(n+1) 2, RX(n+2) 2	Module 3
:	:
RX(n+0) F, RX(n+1) F, RX(n+2) F	Module 16

I/O DATA DESCRIPTIONS

■ MODULE STATUS, ERROR STATUS, DATA ERROR STATUS

Shows each module's availability and error status.

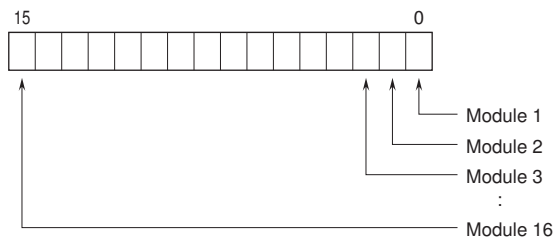

■ ANALOG DATA (models: R3-SV4, YV4, DS4, YS4, US4, etc.)

16-bit binary data.

Basically, 0 to 100% of the selected I/O range is converted into 0 to 10000 (binary). Negative percentage is represented in 2's complements.



■ TEMPERATURE DATA (models: R3-RS4, TS4, US4, etc.)

16-bit binary data.

With °C temperature unit, raw data is multiplied by 10. For example, 25.5 °C is converted into 255.

With °F temperature unit, the integer section of raw data is directly converted into the data.

For example, 135.4 °F is converted into 135.

Minus temperature is converted into negative values, represented in 2's complements.



■ 16-POINT DISCRETE DATA (models: R3-DA16, DC16, etc.)

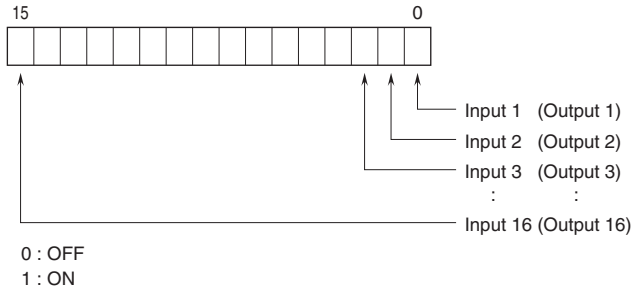

■ PLC REDUNDANT SYSTEM (option /W)

Bit 0 of RY(n+1) is assigned to designate control system or standby system. Set this bit from the host PLC to switch from the PLC master control system to the standby system, or vice versa. The R3 module output (slave station) is controlled according to the bit combinations as shown in the table below. No switching is required for the R3 input modules which continuously send out data to both 'main' and 'sub' network modules.

RY(n+1) 0 = 0 : PLC master control system

RY(n+1) 0 = 1 : PLC standby system

R3 MAIN (RY(n+1) 0)	R3 SUB (RY(n+1) 0)	CONTROL
0	0	Output from the 'main' network module.
0	1	Output from the 'main' network module.
1	0	Output from the 'sub' network module.
1	1	Hold the output

•Operation

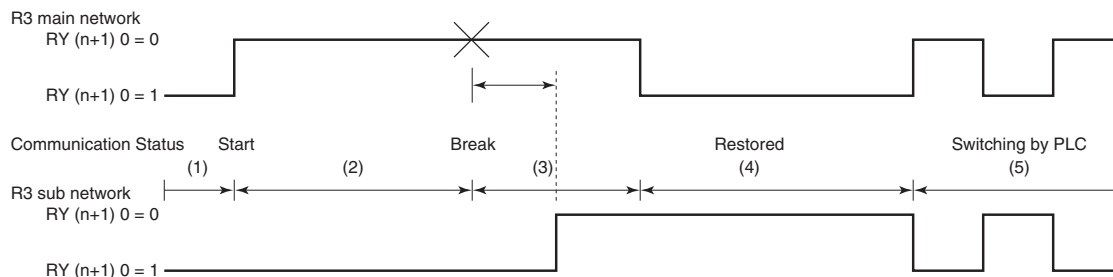

- 1) When the PLC master control/standby system bit is undefined due to no communication, the both host PLCs function as 'standby' system for each of R3 'main' and 'sub' network modules. All contact outputs are off, and analog output modules output -115%.
- 2) The master PLC communicates with the R3 main network module, while the standby PLC communicates with the R3 sub network module.
- 3) When a wire breakdown is detected at the R3 main network, the output signal is held for the preset time period (Timer is programmable with the PC Configurator Software, R3CON). After the time has been elapsed, the output is switched from the R3 main to R3 sub network. Be sure to set an appropriate output signal to the R3 sub network before the switching. The host PLC for the R3 main network is now functioning as standby system.
- 4) Once the PLC control is transferred to the standby system, it is necessary to set RY(n+1) 0 = 1 to the R3 main network in order to prevent R3 output control automatically switched to the main network when the R3 main network is restored. If it is set to RY(n+1) 0 = 0, the R3 output will be switched to the main network even when the PLC control is in the standby system.
- 5) When both R3 main and R3 sub network modules are in communication, the output can be switched without delay by setting RY(n+1) 0 values. Be sure to set an appropriate output signal to the network module before the control is switched to it.



EXTERNAL DIMENSIONS & TERMINAL ASSIGNMENTS unit: mm (inch)

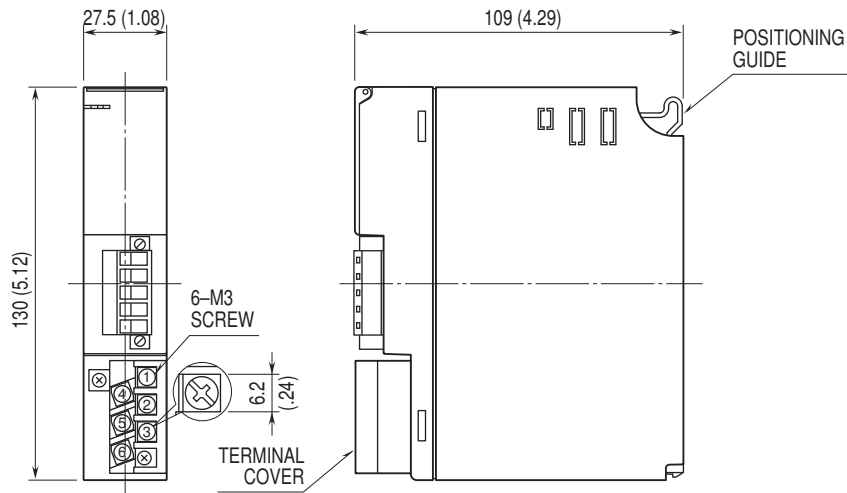

SCHEMATIC CIRCUITRY & CONNECTION DIAGRAM

Note: In order to improve EMC performance, bond the FG terminal to ground.

Caution: FG terminal is NOT a protective conductor terminal.

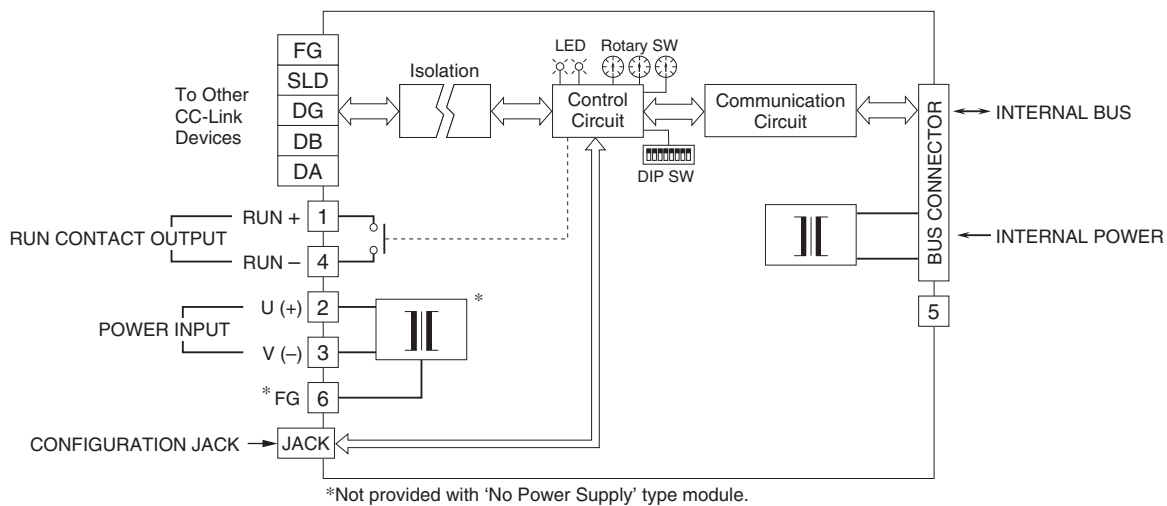

Specifications are subject to change without notice.