

## Remote I/O R3 Series

/C03: Rubber coating

### DeviceNet INTERFACE MODULE

(for 64-point analog signals)

#### Functions & Features

- Enables other protocol interface modules to communicate with DeviceNet data (gateway).
- Recognized as an analog I/O mixed module by other protocol interface modules.
- Used as DeviceNet slave device like R3-NDx.

#### Typical Applications

- A gateway for DeviceNet and Modbus/TCP.

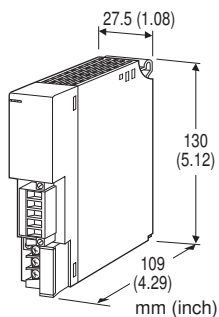

## MODEL: R3-GD1S[1]

### ORDERING INFORMATION

- Code number: R3-GD1S[1]
- Specify a code from below for [1].  
(e.g. R3-GD1S/CE/Q)
- Specify the specification for option code /Q  
(e.g. /C01)

### COMMUNICATION MODE

S: Single

### [1] OPTIONS (multiple selections)

#### Standards & Approvals

blank: Without CE

/CE: CE marking

#### Other Options

blank: none

/Q: Option other than the above (specify the specification)

### SPECIFICATIONS OF OPTION: Q

**COATING (For the detail, refer to M-System's web site.)**

/C01: Silicone coating

/C02: Polyurethane coating

### RELATED PRODUCTS

- EDS file  
(downloadable at M-System's web site.)
- Interface module  
(model: R3-NC1, NC3, NM1, NM4, NE1, NFL1)  
Firmware version V2.00 or later
- Interface Module (model: R3-NML3)  
Firmware version V1.00 or higher

### GENERAL SPECIFICATIONS

#### Connection

**Network:** Euro type connector terminal

**Internal bus:** Via the Installation Base

(model: R3-BSx)

**Internal Power:** Via the Installation Base

(model: R3-BSx)

**RUN contact output:** M3 separable screw terminal

(torque 0.5 N·m)

**Screw terminal:** Nickel-plated steel

**Isolation:** DeviceNet to internal bus or internal power to RUN contact output

**Data allocation:** Set with the side DIP switch.

**RUN contact:** Turns on when both MS and NS LEDs are green (Both the DeviceNet and fieldbus on the other R3 interface module are in normal communication.)

#### ■ RUN CONTACT OUTPUT

**Rated load:** 250 V AC @ 0.5 A (cos  $\phi$  = 1)

30 V DC @ 0.5 A (resistive load)

(Max. 50 V AC to conform with EC Directive)

**Maximum switching voltage:** 250 V AC or 30 V DC

**Maximum switching power:** 250 VA or 150 W

**Minimum load:** 1 V DC @ 1 mA

**Mechanical life:**  $2 \times 10^7$  cycles (300 cycles/min.)

When driving an inductive load, external contact protection and noise quenching recommended.

### DeviceNet COMMUNICATION

**Transmission cable:** Approved for DeviceNet

**Node address setting:** DIP switch; 00 - 63

**Baud rate:** 125 kbps, 250 kbps, 500 kbps DIP switch

**NS (Network Status) indicator:** Bi-color (green/red) LED indicates status of the communication link.

**MS (Module Status) indicator:** Bi-color (green/red) LED indicates device status.

**Required data words:** 64 words for input data 64 words for output data



## INSTALLATION

**Supply voltage to network:** 11 - 25 V DC supplied through the network terminal block

**Supply current to network:** 50 mA max.

**Operating temperature:** -10 to +55°C (14 to 131°F)

**Operating humidity:** 30 to 90 %RH (non-condensing)

**Atmosphere:** No corrosive gas or heavy dust

**Mounting:** Installation Base (model: R3-BSx)

**Weight:** 200 g (0.44 lb)

## PERFORMANCE

**Data allocation:** 16 × n (Module allocation: 1 to 4)

**Current consumption:** 80 mA

**Insulation resistance:** ≥ 100 MΩ with 500 V DC

**Dielectric strength:** 1500 V AC @ 1 minute

(DeviceNet to internal bus or internal power to RUN contact output)

2000 V AC @ 1 minute (power input to FG; isolated on the power supply module)

## STANDARDS & APPROVALS

**CE conformity:**

EMC Directive (2004/108/EC)

EMI EN 61000-6-4: 2007/A1: 2011

EMS EN 61000-6-2: 2005

## EXTERNAL VIEW

### FRONT VIEW

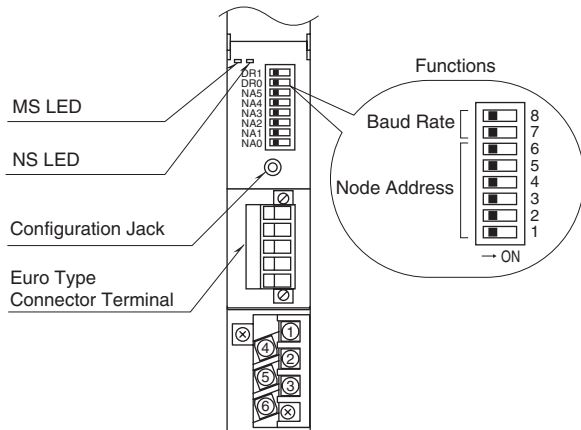

### SIDE VIEW

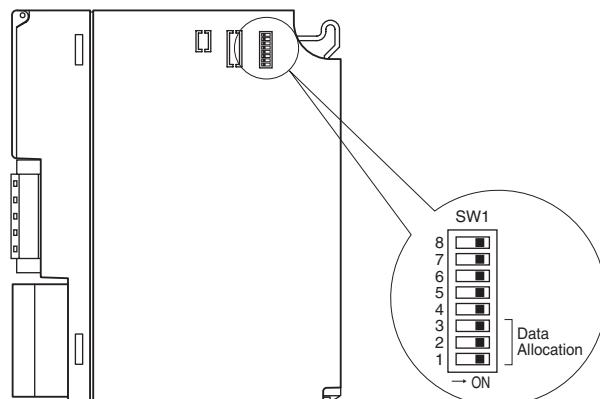

## TRANSMISSION DATA DESCRIPTIONS

Use the DIP SW located at the side of the module to specify module allocation.

1 module is equivalent to 1 I/O module with 16 words analog input and 16 words analog output. Max. 4 modules (64 words input, 64 words output) transmission is available. It seems as if max. 4 I/O modules are mounted to 4 slots via Device-Net.

Note: Do not mount any modules in the slots which are occupied by virtual modules. If a real I/O module is mounted in the slot, an internal bus error occurs and the ERR LED turns on. Max. 16 real I/O modules and virtual modules are available. The interface module can not read the data for more than 16 modules.

### ■ MOUNTED TO SLOT 2 (4 modules)

In practice, I/O modules are mounted to slot 1 and slot 2. The R3-NE1 in slot 7 recognizes the R3-SV4 in slot 1 directly. However, the R3-NE1 recognizes the R3-GD1 in slot 2 as if 4 modules are mounted to from slot 2 to 5.

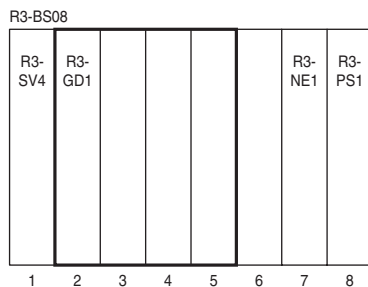

| SLOT   | REAL MODULE | VIRTUAL MODULE | DATA     |
|--------|-------------|----------------|----------|
| Slot 1 | R3-SV4      | R3-SV4         | 4 Words  |
| Slot 2 | R3-GD1      | R3-GD1 (1/4)   | 16 Words |
| Slot 3 | No module   | R3-GD1 (2/4)   | 16 Words |
| Slot 4 | No module   | R3-GD1 (3/4)   | 16 Words |
| Slot 5 | No module   | R3-GD1 (4/4)   | 16 Words |
| Slot 6 | No module   | No module      | -        |
| Slot 7 | R3-NE1      | R3-NE1         | -        |
| Slot 8 | R3-PS1      | R3-PS1         | -        |

### ■ OUTPUT DATA

The figure below shows the allocation of the data sent from the network module to the master.

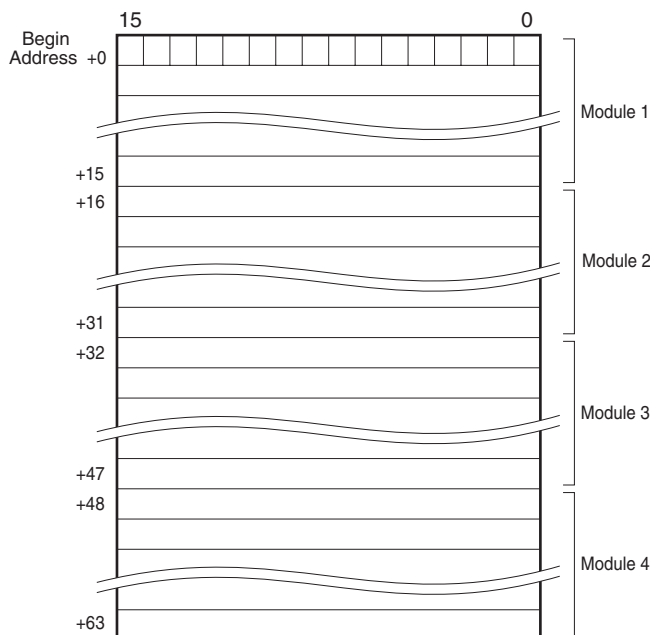

### ■ INPUT DATA

The figure below shows the allocation of the data sent from the master to the network module.

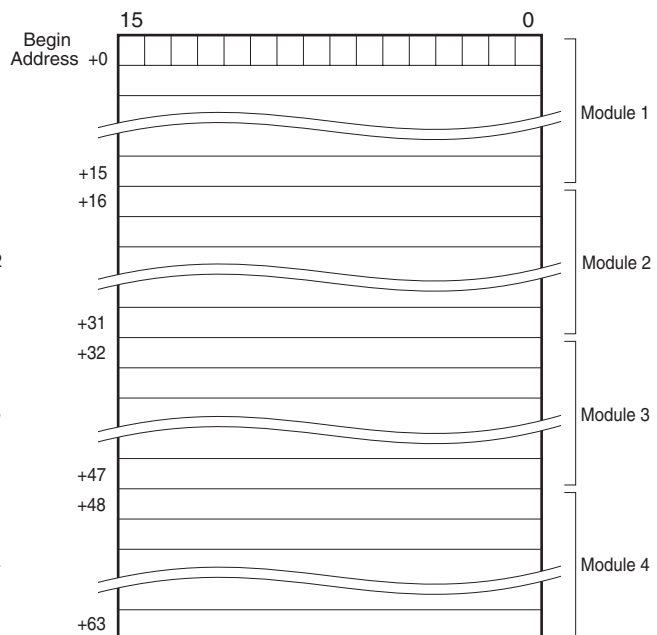

## I/O DATA DESCRIPTIONS

### ■ ANALOG DATA

16-bit binary data.



## EXTERNAL DIMENSIONS & TERMINAL ASSIGNMENTS unit: mm (inch)

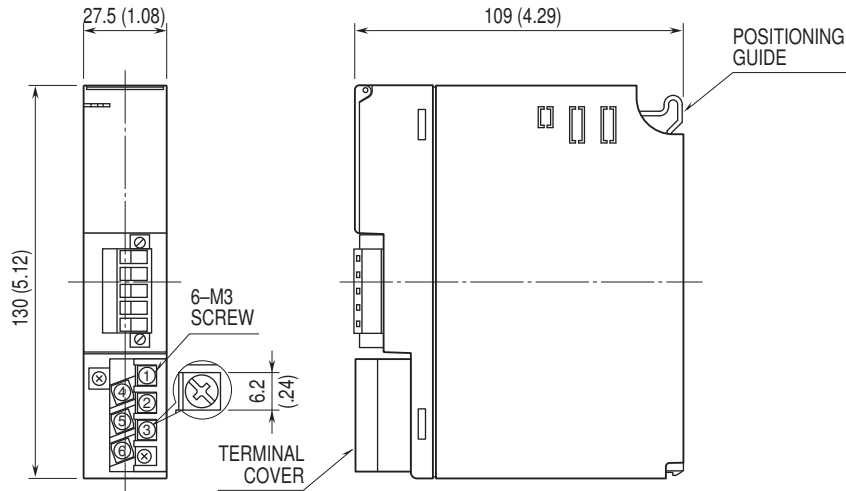

## SCHEMATIC CIRCUITRY & CONNECTION DIAGRAM

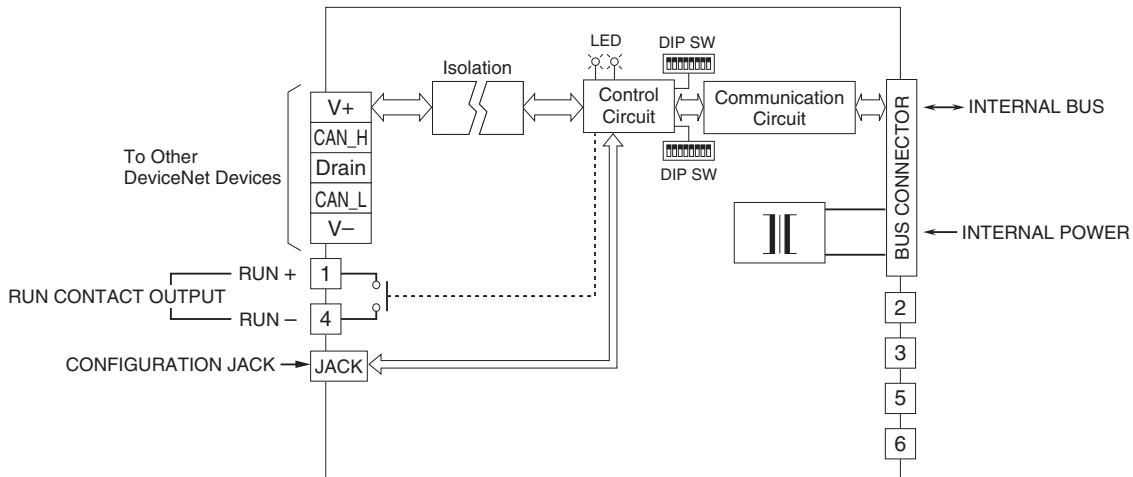

## SYSTEM CONFIGURATION EXAMPLES

When the DeviceNet data is acquired with a PC recorder and this module as a gateway, the system configuration is as follows.

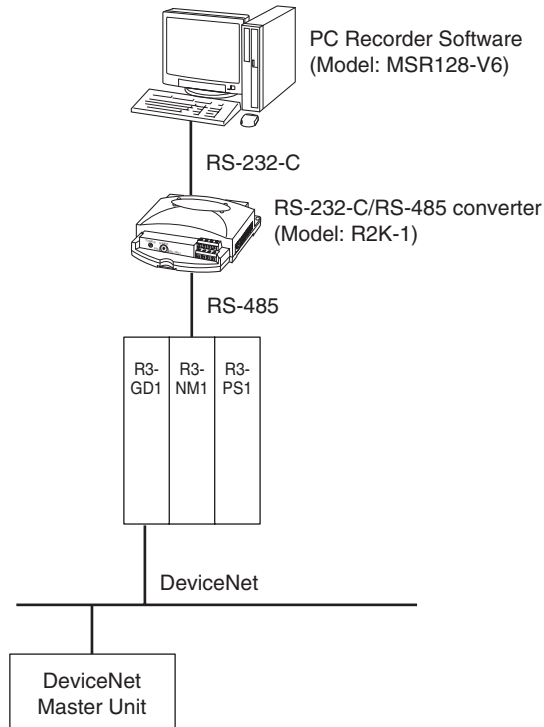

Specifications are subject to change without notice.

